



MANAGING RESOURCES FOR A BETTER FUTURE

STANDARD SPECIFICATIONS

For Public Works Improvements

**Root Creek Water District
PO Box 27950
Fresno, CA 93729**

General Manager: Julia Berry
info@rootcreekwd.com

[\(559\) 255-2305](tel:(559)255-2305)

June 2026

**Root Creek Water District
PO Box 27950.
Fresno, CA 93729**

**STANDARD SPECIFICATIONS
For Public Works Improvements**

June 2026

Cost of Hard Copy - \$10.00
Digital Copy available at no cost

TABLE OF CONTENTS

1	General Requirements	1
1.1	Scope.....	1
1.2	Connection Rules	1
1.3	New Development (Subdivisions or Multiple Parcels).....	1
1.4	Exceptions To These Standard Specifications.....	2
1.5	Incorporation Of State Standard Specifications	2
1.6	Authority Of The Engineer	2
1.7	Contractor's Responsibility For The Work.....	2
1.8	Contractor's Equipment	3
1.9	Suitable Methods	3
1.10	Order Of Work	3
1.11	Superintendence And Personnel	3
1.12	Emergency Availability.....	4
1.13	Preservation Of Property	4
1.14	Protection Of The Work	4
1.15	Rights Of Way.....	4
1.16	Disposal Of Material Outside The Right Of Way.....	5
1.17	Electric And Water Service	5
1.18	Construction Surveying/Staking.....	6
1.19	Cooperation	7
1.20	Maintaining Drainage.....	7
1.21	Inspection During Construction; Meetings	7
1.22	Differing Site Conditions	8
1.23	Removal Of Defective Or Unauthorized Work	8
1.24	Surface Restoration	8
1.25	Final Cleanup.....	9
1.26	Guarantee Of Workmanship	9
1.27	Sand and Grease Interceptors.....	10
1.28	Separation Criteria.....	10
1.29	As-Built Plans	10
1.30	Applicable Fee Structure(s)	10
2	STANDARD SPECIFICATION FOR SANITARY SEWER PIPELINES ...	11
2.1	General.....	11
2.2	Materials	11
2.3	Alignment.....	16
2.4	Excavation, Installation, and Backfill.....	16
3	STANDARD SPECIFICATIONS FOR CONCRETE MANHOLES	24
3.1	General.....	24
3.2	Materials and Workmanship	24
3.3	Construction.....	24

4	STANDARD SPECIFICATION FOR TESTING OF SANITARY SEWERS	26
4.1	General	26
4.2	Mandrel Test	26
4.3	Low-Pressure Air Test	26
4.4	Video Inspection	27
5	STANDARD SPECIFICATION FOR SEWER LIFT STATIONS	29
5.1	General	29
5.2	Minimum General Requirements	29
5.3	Pump Equipment	30
5.4	Pump Disconnect and Guide Rail System	35
5.5	Electrical Controls	35
5.6	Additional Information	39
5.7	Stand-by Power	39
6	STANDARD SPECIFICATION FOR PVC WATER PIPE	41
6.1	Materials and Assembly	41
6.2	Fittings	41
6.3	Alignment	41
7	STANDARD SPECIFICATIONS FOR BLOW-OFF ASSEMBLIES	42
7.1	General	42
7.2	Materials, Fabrication and Installation	42
8	STANDARD SPECIFICATIONS FOR WATER SERVICE ASSEMBLIES TWO INCHES AND SMALLER	43
8.1	General	43
8.2	Materials, Fabrication, and Installation	43
9	STANDARD SPECIFICATIONS FOR GATE VALVE ASSEMBLIES	45
9.1	General	45
9.2	Materials, Fabrication and Installation	45
10	STANDARD SPECIFICATION FOR WATER SERVICE TUBING	47
10.1	Copper Tubing	47
10.2	Polyethylene (PE) Tubing	47
10.3	Installation and Fittings	47
11	STANDARD SPECIFICATIONS FOR FIRE HYDRANT ASSEMBLIES	48
11.1	General	48
11.2	Materials, Fabrication and Installation	48
12	STANDARD SPECIFICATIONS FOR MANUAL AIR RELEASE ASSEMBLIES	50
12.1	General	50
12.2	Materials, Fabrication and Installation	50

13	STANDARD SPECIFICATIONS FOR TESTING AND STERILIZATION	51
13.1	General	51
13.2	Acceptance Tests And Inspection For Pressurized Water Piping ..	51
13.3	Field Testing	51
13.4	Disinfection	54
14	POLYPROPYLENE (PP) PLASTIC PIPE	57
14.1	General	57
14.2	Materials	57
14.3	Installation.....	58
14.4	Curved Alignments	61
14.5	Protection of Pipe	62
14.6	Testing	62
14.7	Measurement and Payment.....	63
15	REINFORCED CONCRETE PIPE (RCP).....	64
15.1	General	64
15.2	Materials, Pipe	64
15.3	Materials, Joints.....	64
15.4	Installation.....	65
15.5	Alignments	66
15.6	Protection of Pipe	66
15.7	Video Inspection	67
15.8	Measurement and Payment.....	67
16	STANDARD SPECIFICATIONS FOR STORM DRAIN.....	68
16.1	Acceptance Tests for Buried RGRCP and PP Plastic Storm Piping.....	68
17	STANDARD SPECIFICATIONS FOR EARTHWORK (PIPELINES)	69
17.1	General Conditions	69
17.2	Materials and Workmanship	70
17.3	Backfill	72
17.4	Compaction.....	72
18	STANDARD SPECIFICATIONS FOR EARTHWORK (STRUCTURES AND MISCELLANEOUS PIPING)	75
18.1	General Conditions	75
18.2	Grading	77
18.3	Soil Sterilant.....	78
18.4	Structure Excavation and Backfill	78
18.5	Final Clean-Up.....	80
19	STANDARD SPECIFICATION FOR ASPHALT CONCRETE PAVEMENT	81
19.1	Aggregate Sub-base	81
19.2	Aggregate Base	81
19.3	Asphalt Concrete	81

19.4	Asphaltic Paint Binder.....	82
19.5	Sand Application.....	82
19.6	Spreading and Compaction of Asphalt Concrete Paving.....	82
19.7	Finishing Roadway.....	84
19.8	Fog Seal.....	84
20	STANDARD SPECIFICATION FOR PORTLAND CEMENT CONCRETE IMPROVEMENTS.....	85
20.1	General.....	85
20.2	Portland Cement Concrete.....	85
20.3	Construction.....	89
20.4	Rock Pockets.....	90
20.5	Backfilling Improvements.....	90
21	STANDARD SPECIFICATIONS FOR DUST CONTROL.....	91
21.1	General.....	91
21.2	Materials and Application.....	91
22	STANDARD SPECIFICATIONS FOR MAINTENANCE OF TRAFFIC AND DETOURS.....	93
22.1	General.....	93
22.2	Construction Signage.....	93
22.3	Vehicular Traffic Control.....	93
22.4	Street Closure.....	94
22.5	Permanent Traffic Controls.....	94
22.6	Pedestrian Traffic Control.....	94
22.7	Access to Adjacent Properties.....	94
23	JACKING PIPE.....	95
23.1	General.....	95
23.2	Materials.....	95
23.3	Excavation of Jacking and Receiving Pits.....	95
23.4	Boring and Jacking.....	96
23.5	Grade Tolerance.....	97
23.6	Backfill, Compaction and Restoration of Surfaces for Jacking and Receiving Pits.....	97
23.7	Measurement.....	97
23.8	Payment.....	98

1 GENERAL REQUIREMENTS

1.1 Scope

This book of specifications governs construction of municipal public works improvements (water, sewer, and storm) in the Root Creek Water District (RCWD). All work done within the public rights-of-way, whether performed by a Contractor under contract to RCWD or by another party, shall be in conformance with this document. These specifications shall also govern work on private property which serves a public purpose, such as utility pipelines. These projects shall be referred to in this document as "public works."

1.2 Connection Rules

No party or parties shall be allowed to connect to water, sanitary sewer, or storm facilities of RCWD for a building, subdivision or any other purpose without first obtaining the consent of the Board of Directors of RCWD entering into a permit with RCWD, paying the required plan review, inspection and connection fees as identified in RCWD regulations.

All RCWD fees shall be paid in full prior to application for Madera County Building Permit. If no building permit is required, RCWD fees shall be paid prior to start of construction.

RCWD requirements separate water, sanitary sewer, and storm services for each property within RCWD.

1.3 New Development (Subdivisions or Multiple Parcels)

Extension of water, sanitary sewer, and storm improvements into new developments requires the following:

1. Developer's engineer shall submit 3 sets of plans and specifications for the proposed improvements, together with the applicable plan check fee, to RCWD for review by the District's Engineer. Plans shall be on 24"x36" sheets, single- or double-window plan-and-profile, and shall be drawn to scale (minimum 1"=40' horizontal, 1"=4' vertical.)
2. Execution of a Development Agreement between RCWD and the Developer, stipulating the conditions of providing the proposed improvements. Topics covered by the agreement may include indemnification, bonding requirements, maintenance and repair, and fees to be paid.
3. Payment of required connection and inspection fees. Fees amounts shall be calculated pursuant to the schedule in effect at the time of fee payment.
4. Water and sewer mains must extend along the entire frontage of the property.
5. Water, sewer and storm drain facilities proposed for new development must be in public right of ways. In areas where the proposed facility is not within the street right of way, a minimum 30 feet wide outlot shall be provided. The acceptance of the size and location of the proposed outlot will be at the discretion of the District Engineer. The access to any water, sewer or storm drain must be accessible from public streets and roads.

1.4 Exceptions To These Standard Specifications

The only exceptions to this policy shall be those approved in writing by the District Engineer. RCWD reserves the right to enforce a more stringent requirement in any given situation where, in the opinion of the District Engineer or the Board of Directors (referred to herein collectively as the District Engineer), site conditions so dictate.

1.5 Incorporation Of State Standard Specifications

All public works shall be constructed in accordance with the appropriate provisions and construction details of the latest edition of *Standard Specifications*, published by the State of California Department of Transportation (CALTRANS), insofar as they may apply. In case of a conflict between the State Standard Specifications (referred to herein as *State Standard Specifications*) and this document, this document shall take precedence.

The public works improvements may also be required to conform to California Water Works Standards and American Public Works Association, Standard Plans and Standard Specifications.

Measurement and payment clauses have been omitted from this document. Such clauses appear in the Special Provisions of publicly-funded projects as needed. The measurement and payment clauses in the State Standard Specifications do not apply.

1.6 Authority Of The Engineer

The Engineer shall decide all questions which may arise as to the quality or acceptability of materials furnished and work performed and as to the manner of performance and rate or progress of the work, all questions which may arise as to the interpretation of the Plans and Specifications, all questions as to the acceptable fulfillment of the Contract on the part of the Contractor, and all questions as to compensation, including any claims and change orders. The Engineer's decision shall be final and binding upon the Contractor. The Engineer shall also have the authority to enforce and make effective such decisions and orders which the Contractor fails to carry out promptly. In accordance with Section 1.21, "Inspection during Construction," -the Engineer will delegate authority to representative inspectors to assure compliance with Plans and Specifications.

1.7 Contractor's Responsibility For The Work

Except as specifically provided in these Standard Specifications, until the formal acceptance of the work by the District, the Contractor shall have the charge and care thereof and shall bear the risk of injury or damage to any part thereof by the action of the elements or from any other cause, whether arising from execution or from the nonexecution of the work. The Contractor shall rebuild, repair, restore and make good all injuries or damages to any portion of the work occasioned by any of the above causes before final acceptance and shall bear the expense thereof, except such injuries or damages occasioned by acts of the Federal Government or the public enemy. The District shall not be held responsible for the care or protection of any material or parts of the work prior to final acceptance, except as expressly provided in the Specifications.

The Contractor shall comply with the requirements of Sections 1.13, "Preservation of Property."

1.8 Contractor's Equipment

The Contractor shall provide adequate and suitable equipment and means of construction to meet all the requirements of the work. When ordered to do so by the Engineer, the Contractor shall remove unsuitable equipment from the work and discontinue the operation of unsatisfactory equipment. The use of any equipment which is obsolete as to type, in bad condition, or worn out will not be permitted on the work.

1.9 Suitable Methods

The Contractor shall use such methods for the performance of the work embraced under these Specifications as will secure a satisfactory quality of work and rate of progress. Such methods shall meet the approval of the Engineer, and shall be submitted for approval before being used on the work. The Engineer reserves the right, during the progress of the work, to make suggestions and revisions in the methods in order that a high quality of work and satisfactory rate of progress may be obtained. When ordered by the Engineer, the Contractor shall discontinue unsuitable methods of work site.

1.10 Order Of Work

Where required by the Plans or Specifications, the Contractor shall follow the sequence of operations as set forth therein.

1.11 Superintendence And Personnel

The Contractor shall designate in writing before starting work, an authorized representative who shall have the authority to represent and act for the Contractor, to receive suggestions or direction from the Engineer or Inspector and to see them faithfully executed. The Contractor shall provide the name, address, and phone number of each such superintendent or foreman so designated. When the Contractor is comprised of 2 or more persons, firms, partnerships or corporations functioning on a joint venture basis, the Contractor shall designate in writing before starting work, the name of one authorized representative who shall have the authority to represent and act for the Contractor.

The authorized representative shall be present at the site of the work at all times while work is actually in progress on the contract. When work is not in progress and during periods when work is suspended, arrangements acceptable to the Engineer shall be made for any emergency work which may be required.

Whenever the Contractor or the Contractor's authorized representative is not present on any particular part of the work where it may be desired to give direction, orders will be given by the Engineer which shall be received and obeyed by the superintendent or foreman who may have charge of the particular work in reference to which the orders are given.

Any order given by the Engineer, not otherwise required by the Specifications to be in writing, will on request of the Contractor, be given or confirmed by the Engineer in writing. If any subcontractor, workman, or person employed by the Contractor shall fail or refuse to carry out the directions of the Engineer, or shall appear to the Engineer to be incompetent or to act in a disorderly or improper manner, that person shall be removed from the work immediately upon notice by the Engineer and may not be employed again

on the work. All work shall be under general observation and inspection of the Engineer or the Inspector and any work done without the sanction or presence of the Engineer or Inspector will be subject to rejection.

1.12 Emergency Availability

The Contractor shall furnish to the Engineer, prior to the issuance of a "Notice to Proceed," a list of persons, together with their addresses and 24-hour telephone numbers, who are authorized to act on behalf of the Contractor in an emergency arising out of conditions at the work site after normal working hours. The Contractor shall conform to the requirements in Section 1.14, "Protection of the Work."

1.13 Preservation Of Property

In accordance with Sections 1.7, "Contractor's Responsibility For Work," the Contractor shall be liable for any and all damage done to any public or private property, structure, facility or improvement due to his operations. Due care shall be exercised to avoid injury to existing street improvements or facilities, roadside trees and landscaping that are not to be removed, pole lines, fences, signs, survey markers and monuments, buildings and structures, conduits, pipelines under or above ground, all street facilities, and any other improvements or facilities within or adjacent to the work area, or on private property adjacent to the work area, and all such facilities shall be protected from injury or damage. The Contractor shall provide and install suitable, approved safeguards to protect property or improvements from injury or damage.

If property or improvements are injured or damaged by reason of the Contractor's operations, they shall be replaced or restored to a condition as good as when the Contractor entered upon the work or as good as required by the specifications being performed under this Contract. In certain cases, where the Contractor damages an existing facility such as a curb return and or landing, the Engineer may require the Contractor at his expense to reconstruct the return to meet current Americans With Disabilities Act (ADA) requirements and standards.

The Engineer may make or cause to be made such temporary repairs as are necessary to restore to service any damaged facility. The cost of such repairs shall be borne by the Contractor and may be deducted by the District from any monies due or to become due to the Contractor under the Contract.

1.14 Protection Of The Work

The Contractor shall provide and maintain proper barricades, fences, signal lights or watchmen to properly protect the work, persons, animals, and property against injury. The cost of such protection shall be included in the amount bid for the various items of work.

1.15 Rights Of Way

Right of way for the work to be constructed will be dedicated to the District and as shown on the Plans. The Developer/Contractor shall procure at no cost to the District all right of way required for the improvements. Temporary construction easements needed by contractors in the course of their construction activities and not shown in the Plans, which the contractor may deem necessary to carry out the work to be done under the Contract

will be acquired by the contractor. The Contractor shall bring said temporary construction easements to a condition at least equal to that existing prior to their use, to the satisfaction of the Engineer. The Contractor shall not occupy property outside the right-of-way shown on the Plans, except by written agreement with the owner of said property, a copy of which shall be provided the Engineer.

Nothing in these Standard Specifications shall be construed as allowing the Contractor to make any arrangements with any person to permit occupancy or use of any land, structure, or building within the limits of the Contract for any purpose whatsoever, either with or without compensation, in conflict with any agreement between the owner, former owner, or tenant of such land, structure or building.

1.16 Disposal Of Material Outside The Right Of Way

The Contractor shall make arrangements for the legal disposal of material. No recyclable material shall be disposed of at any landfill. All disposable recyclable materials shall be disposed in a manner that facilitates recycling. A certificate of compliance stating disposal location and manner of disposal of recyclable materials shall be submitted to the Engineer.

When any material is to be disposed of outside the right of way, the Contractor shall first obtain a written permit from the property owner on whose property the disposal is to be made and shall file with the Engineer said permit or a certified copy thereof. When material is disposed of as above provided, the Contractor shall conform to all requirements pertaining to grading, hauling and filling of earth, including any permits or bonds so required.

The contractor shall clean up and dispose of all excess materials and other debris in any right of way or ground occupied by him and shall restore utilities and improvements on public or private property that has been used or damaged by his operations. Full compensation for all costs involved in disposing of materials as specified in this Section, including all costs of hauling and any landfill or other fees, shall be considered as included in the price paid for the Contract items of work involving such materials and no additional compensation will be allowed therefor. No additional payment will be granted the Contractor for inconvenience or delays encountered in complying with the requirements of this Section.

1.17 Electric And Water Service

The Contractor shall provide and pay for electric service for power and lighting required for the construction of the work of the Contract and shall maintain such service until the completion of the Contract.

The Contractor shall make arrangements for and shall acquire a water supply for the work done under the Contract. The Contractor shall pay for all water so used. In accordance with provisions of the District, water to be used in work contracted to the District may be taken from the District's water system, at a location approved by the District. If taken from the District's water system, the Contractor shall obtain a water meter from the District, and pay any deposits or fees required therefor, including charges for water used. Failure to return the meter at specified intervals for reading, and/or late return of the meter when the work is completed, will result in additional fees. A backflow prevention device may be

required by the District and shall be furnished and installed by the Contractor prior to any water being taken from the District's system.

Water taken from a source other than the District system shall be approved by the Engineer in advance. Such water shall be chemically and biologically suitable for the intended use.

The Contractor will be charged for all water consumed through the hydrant meter, including water consumed for testing purposes through the 90-day maintenance period and up to final acceptance of the work by the Engineer. All costs for furnishing electric service and water, including water consumed for landscape irrigation and irrigation system testing, shall be included in the various related bid items of work; no additional payment will be made therefor.

1.18 Construction Surveying/Staking

Unless otherwise specified in the Contract Specifications, construction surveying and staking shall be provided by the Contractor. Surveying and staking shall be conducted only by a person licensed by the State of California to practice Land Surveying. Surveying shall conform to the quality and practice required by the Engineer. The Engineer shall be notified before surveying and/or construction staking commences. Prior to starting work or upon District written request, Contractor shall furnish a copy of Laser Level testing and calibration certification in a timely manner. If such request is not received within 7 calendar days upon written request, Contractor shall be directed to stop work until certification is received and accepted. Laser Level shall be secured to a tripod that is in good working condition. If a tripod is not used the District shall direct the Contractor to stop work until such time as a tripod in good working condition is utilized. The contractor shall furnish cut-sheets prepared by the surveyor to the Engineer immediately upon the setting of the grades. The Contractor shall preserve construction survey stakes and marks for the duration of their usefulness. The Contractor shall be responsible for the replacement cost of any lost or disturbed construction staking necessary to complete the work.

The Contractor shall immediately inform the Engineer in writing of any discrepancies discovered during the course of the work between the Plans and the construction staking, and the Engineer shall promptly verify the same. Any work done after such discovery, until authorized, will be done at the Contractor's risk. Three consecutive points set on the same slope shall be used together so that any variation from a straight grade can be detected. Any such variation shall be reported to the Engineer. Any deviation of constructed facilities from the grades shown on the Plans and staked in the field shall be the responsibility of the Contractor. Grades for underground conduits will be set at the surface of the ground and the Contractor shall be responsible for transferring such grades to the bottom of the trench. The Contractor shall preserve property line and corner survey markers, except where their destruction is unavoidable when the Contractor is proceeding in accordance with accepted practice. Markers that are lost or disturbed by his operations shall be replaced at the Contractor's expense by a person appropriately licensed by the State of California for Land Surveying.

The costs for furnishing Construction Surveying and Staking by the Contractor shall be included in the amount bid for the various items of work; no separate payment will be made therefor.

1.19 Cooperation

The Contractor shall cooperate in all respects with all public and private agencies, including the County of Madera, Cable TV and Telephone Companies, and Pacific Gas and Electric Company.

Should construction be under way by other forces or by other contractors within or adjacent to the limits of the work specified or should work of any other nature be under way by other forces within or adjacent to those limits, the Contractor shall cooperate with all the other contractors or other forces to the end that any delay or hindrance to their work will be avoided. The right is reserved to perform other or additional work at or near the site (including material sources) at any time, by the use of other forces.

When 2 or more contractors are employed on related or adjacent work, or obtain materials from the same material source, each shall conduct their operations in such a manner as not to cause any unnecessary delay or hindrance to the other. Each contractor shall be responsible to the other for all damage to work, to persons or property caused to the other by their operations, and for loss caused the other due to unnecessary delays or failure to finish the work within the time specified for completion.

1.20 Maintaining Drainage

The Contractor shall provide and maintain drainage to the area of work. Temporary provisions for drainage of any area during construction where existing drainage facilities have been damaged or altered or where normal drainage patterns of adjacent areas will be interrupted by the Contractor during his operations, shall be made by the Contractor and as directed by the Engineer.

The Contractor shall be responsible for all damages to public or private property upstream or downstream of the work incurred due to failure to provide adequate drainage within and through the construction area or due to blockage of existing drainage facilities or pathways at or upstream from the area of work, or for re-routing flows to areas not historically receiving such drainage.

The costs for Maintaining Drainage by the Contractor shall be included in the amount bid for the various items of work; no separate payment will be made therefor.

1.21 Inspection During Construction; Meetings

As provided in Section 1.6, "Authority of the Engineer," the Engineer will delegate - authority to a representative Inspector who shall at all times have access to the work during construction and shall be furnished with every reasonable facility for ascertaining full knowledge relative to the progress, workmanship, and character of materials used and employed in the work. The Contractor shall provide facilities necessary to ensure the safety of the Engineer, District inspectors, and the personnel of authorized testing firms as appropriate. The District and its agents, employees, inspectors and testing firms may videotape, audiotape, or photograph any aspect of the Work or Contractor's activities as part of their documentation of the project and certain issues. Whenever the Contractor

varies the day, or period of the day, during which work is performed, he shall give due notice to the Engineer or Inspector so that proper inspection may be provided. Any work done in the absence of the Engineer or Inspector is subject to rejection. The inspection, approval and/or acceptance of the work shall not relieve the Contractor of any obligations to fulfill the Contract as prescribed. Defective work shall be made good and unsuitable materials may be rejected, notwithstanding the fact that such defective work and unsuitable materials may have been previously overlooked by the Engineer or Inspector and accepted, or estimated for payment. Projects financed in whole or in part with funds from sources other than the District shall be subject to inspection at all times by the agency providing said funds or its authorized agent. When specified in the Contract Specifications, the Contractor shall meet no less than weekly with the District to review all construction issues. The District shall prepare minutes for each meeting and forward them to Contractor; Contractor's failure to correct the minutes within four (4) days shall be deemed agreement with the content of the minutes. Either party has the right to audiotape or videotape the weekly meeting.

1.22 Differing Site Conditions

During the progress of the work, if subsurface or latent physical conditions are encountered at the site differing materially from those indicated in the contract or if unknown physical conditions of an unusual nature, differing materially from those ordinarily encountered and generally recognized as inherent in the work provided for in the contract, are encountered at the site, the party discovering those conditions shall promptly notify the other party in writing of the specific differing conditions before they are disturbed and before the affected work is performed.

Upon written notification from the Contractor, the Engineer will investigate the conditions, and if the Engineer determines that the conditions materially differ and cause an increase or decrease in the cost or time required for the performance of any work under the contract, an adjustment, excluding loss of anticipated profits, will be made and the contract modified in writing accordingly. The Engineer will notify the Contractor of the Engineer's determination whether or not an adjustment of the contract is warranted. No contract adjustment which results in a benefit to the Contractor will be allowed unless the Contractor has provided the required written notice.

No contract adjustment will be allowed under the provisions specified in this section for any effects caused on unchanged work.

1.23 Removal Of Defective Or Unauthorized Work

All work which is defective in its construction or deficient in any of the requirements of the contract documents shall be remedied or removed and replaced by the Contractor in an acceptable manner and no compensation will be allowed for such correction. Any work done beyond the lines and grades shown on the Plans or established by the Engineer or any extra work done without written authority will be considered as unauthorized and will not be paid for.

1.24 Surface Restoration

The Contractor shall replace all graded surface material adjacent and/or appurtenant to the work removed, disturbed, or damaged by the Contractor's operations, and shall

restore paving, curbing, sidewalks, gutters, landscaping, fences, lawn and other surfaces disturbed, to a condition equal to that before the work began or as indicated in the Contract Specifications or Plans, and shall furnish all labor and material incidental thereto. Where bid items are not provided for each type of restoration, full compensation therefor shall be included in the amount bid for the various items of Contract work.

1.25 Final Cleanup

When construction is completed, and prior to application for acceptance of the work, the Contractor shall clean all work areas and all grounds occupied by him in connection with the work of all debris, excess materials, temporary structures and equipment. All portions of the work shall be left in a neat, presentable condition. The roadways in which construction operations have been accomplished, as well as all haul roads upon which spillage has occurred, shall be swept clean, as directed by the Engineer. Roads adjacent to construction activity which have received dirt or debris tracked from the construction area shall also be swept and cleaned. Upon completion of Final Cleanup, the Contractor shall notify the Engineer in writing that the work is complete in all parts and requirements and ready for final inspection. If the Contractor fails to provide Final Cleanup to the satisfaction of the Engineer, a final inspection will not be performed by the Engineer until such cleanup is provided. If the contract time is exceeded due to the Contractor's failure to provide, or is late in providing, the required final cleanup, Liquidated Damages, will be applied. All costs for providing Final Cleanup shall be included in the various bid items of work; no additional payment will be made therefor.

1.26 Guarantee Of Workmanship

The Contractor shall guarantee all materials, equipment and workmanship of the installation and Work for a period of one year from the date of Acceptance of the Work by the District. Additional longer guarantees may be required by the Contract Specifications. Should any material or appliance or any work develop any defect or weakness due, in the opinion of the Engineer, to the use of imperfect materials, equipment or workmanship, or failure to follow the Contract, including the Plans and Specifications, the Contractor shall be notified within the time period of the Guarantee, and shall immediately perform, at Contractor's expense, the necessary repairs or replacements to make the defective item or items suitable and satisfactory. Expiration of the Guarantee time period shall not void an obligation of the Contractor which is based on a timely notice by the District. Should emergencies necessitate the repairs before the Contractor could be notified, or should the Contractor refuse to make the repairs or replacements within a reasonable period of time, the Engineer shall have the right to make the necessary repairs or replacements at the expense of the Contractor, preserving as far as possible all available evidence of the cause of failure.

This guarantee provision applies to all work performed in District right-of-way or property, whether by contract with the District or work performed under Encroachment Permit by or for utility or communications companies or other private entities. For work done under Encroachment Permit, failure to correct or pay for defective workmanship or materials may result in denial of future permits to perform work in District rights-of-way or property.

All costs for providing all required Guarantees of Workmanship shall be included in the various bid items; no additional payment will be made therefor

1.27 Sand and Grease Interceptors

Sand and grease interceptors shall be constructed in accordance with the Standard Drawings of these Specifications and the Plans as specified and directed by the Engineer.

1.28 Separation Criteria

All sanitary sewers and water mains shall meet the separation standards of the "California Waterworks Standards" contained in Section 6403, Title 22 of the California Administrative Code, or shall be installed in accordance with alternate construction criteria as specified therein.

1.29 As-Built Plans

The Contractor shall have on the project site, at all times, an up-to-date record of the work being performed. At the completion of any construction, installation, modification, additional, or deletion of any water or sewer facility, the Contractor shall furnish RCWD with a reproducible copy and an electronic copy of the Record Construction Drawings in PDF format.

1.30 Applicable Fee Structure(s)

All applicable fee structures are due and payable to the office of the Root Creek Water District.

Administration, Legal & Engineering Fees:

RCWD will charge applicants for costs associated with processing of requests for service.

Connection Fees:

Connection fees for water and sewer service are established by the Board of Directors pursuant to an adopted Capital Facilities Plan. The adopted plan is available for review at RCWD office.

Annexation Fees:

Annexation fees will be determined on an individual basis.

Inspection Fees:

RCWD shall charge the applicant for costs incurred for construction review of improvements to be constructed and offered for dedication to RCWD.

2 STANDARD SPECIFICATION FOR SANITARY SEWER PIPELINES

2.1 General

Sewer pipe, manholes, stub-outs, house branches, and service laterals shall be furnished in accordance with the requirements established in these specifications. Also included is the testing and internal inspection of all sewer lines.

No public sewer may be smaller than eight inches (8") in diameter.

2.2 Materials

Sewer pipe and fittings shall be unplasticized polyvinyl chloride (PVC) pipe, as specified herein.

2.2.1 Polyvinyl Chloride Pipe

- Manufacturing Requirements

A. Identification Marks

- All pipe, fittings, and couplings shall be clearly marked at intervals not to exceed 5 feet as follows:
 - Nominal pipe diameter
 - PVC cell classification
 - Company, plant, shift, ASTM, SDR, and date designation

For fittings and couplings, the SDR designation is not required.

- Cell Classification

PVC pipe shall be made of PVC compound having a cell classification of 12454-B, 13364-A, or 13364-B conforming to ASTM D1784. The fittings shall be made of PVC compound having a cell classification of 12454-B, 12454-C, or 13343-C. Additives and fillers, including but not limited to stabilizers, antioxidants, lubricants, colorants, etc., shall not exceed 10 parts by weight per 100 of PVC resin in the compound.

- Joining Systems

B. General

All pipes shall have a home mark on the spigot end to indicate proper penetration when the joint is made. The socket and spigot configurations for the fittings and couplings shall be compatible to those used for the pipe.

The use of solvent weld pipe and fittings are prohibited except solvent weld caps may be used at the temporary ends of sewer services.

C. Elastomeric Gasket Joints

Pipe shall be manufactured with a socket configuration which will prevent improper installation of the gasket and will ensure that the gasket remains in place during the joining operation.

PVC pipe shall be joined with rubber gaskets. Rubber gaskets shall be manufactured from a synthetic elastomer and shall comply in all respects with the physical requirements specified in ASTM F477. The compound shall contain not less than 50% by volume of first-grade rubber. The remainder of the compound shall consist of pulverized fillers free of rubber substitutes, reclaimed rubber, and deleterious substances. The Contractor shall retest within 60 days prior to installation, any pipe gasket that is more than 180 days old from the date of manufacture to ensure compliance with the requirements of the Specifications.

The Contractor shall not install any pipe gasket that is more than 2 years old from the date manufacture.

Gaskets shall be extruded or molded and cured in such a manner as to be dense, homogenous and of smooth surface, free of pitting, blisters, porosity and other imperfections. The tolerance for any diameter measured at any cross section shall be $\pm 1/32$ inch.

When required by the Engineer, the Contractor shall furnish test samples of gaskets from each batch used in the work. Gasket material shall meet the following requirements:

Property	Value	ASTM Test Method
Tensile strength, psi min.	1500	D412
Elongation at break (% min.)	350	D412
Shore durometer, Type A (Pipe manufacturer shall select value suitable for type of joint)	40 to 65	D2240
Compression set (constant deflection) max % of original deflection	16	D395 Method B
Tensile strength after oven aging (96 hours, 158°F) % of tensile strength before aging	80	D573
Increase in shore durometer hardness after over aging. Maximum increase over original Shore durometer	10	D2240
Physical requirements after exposure to ozone concentration (150 pphm. 70 hours 104°F, 20% strain)	No cracks	D1149

No more than one splice will be permitted in a gasket. A splice shall be made by applying a suitable cement to the ends and vulcanizing the splice in a full mold. The splice shall show no separation when subjected to the following tests:

Elongation Test

The part of the gasket which includes the splice shall withstand 100 percent elongation with no visible separation of the splice. While in the stretched position, the gasket shall be rotated in the spliced area minimum of 180° in each direction in order to inspect for separation.

Bend Test

The portion of the unstretched gasket containing the splice shall be wrapped a minimum of 180° and maximum of 270° around a rod of a diameter equal to the cross section diameter of the gasket.

Solvent cements are not allowed for joining pipe for 4” and larger as specified an approved by District Engineer.

- Test Requirements

D. General

Pipe, fittings, and couplings shall meet the requirements of the section titled “Requirements” of ASTM D3033, D3034, F679 (“T-1” wall only). During production of the pipe, the manufacture shall perform the specified tests for each pipe marking. A certification by the manufacture indicating compliance with the specification requirements shall be delivered with the pipe. The certification shall include the test result data. The PVC compound shall also meet the chemical resistance requirements of 2.2.1.G.

E. Acceptance

The basis for acceptance will be the inspection of pipe, fittings, and couplings; the tests specified in subsection 2.2.1.D, and compliance with the Specifications. When the pipe is delivered to the Work site, the Engineer may require additional testing to determine conformance with the requirements of pipe flattening, impact resistance, pipe stiffness, and extrusion quality. Installation time shall conform to subsection 2.2.1.H.

F. Selection of Test Pipe

When testing is required by the Engineer, one test pipe shall be selected at random by the Engineer from each 1200 feet or fraction thereof of one test pipe per lot. A lot shall be defined as pipe having the same identification marking. The length of specimen for each selected pipe shall be a minimum of eight feet (8').

G. Chemical Resistance And Physical Testing

The Engineer may at any time direct the manufacturer to obtain compound samples and prepare test specimens in accordance with ASTM D1987. These specimens shall comply with the minimum property values shown below and also with the applicable ASTM requirements.

Property	ASTM Test Method	Value (Initial and After 112 Days Exposure)		
		Cell Class 12454	Cell Class 13343	Cell Class 13364
Minimum Yield Strength (psi)	D 638	7,000	6,000	6,000
Impact Strength (Ft.-lbs/in) Notch Min.	D 256 Method A (Size 1/2"x1/8"x2-1/2")	0.65	1.5	1.5
Weight Change % Unconditioned Conditioned	D 543	±1.5 max ± 1.0 min	± 1.5 max ± 1.0 min	± 1.5 max ± 1.0 min

Tensile and impact exposure specimens shall be immersed in the following solutions for a period of 112 days. At 28-day intervals, selected specimens shall be removed, washed, surface dried and tested.

Chemical Solution	Concentration
Sulphuric Acid (H ₂ SO ₄)	20% ¹
Sodium Hydroxide (NaOH)	5%
Ammonium Hydroxide (NH ₄ OH)	5% ¹
Nitric Acid (HNO ₃)	1% ¹
Ferric Acid (FeCl ₃)	1%
Sodium Hypochlorite	1%
Soap	0.1%
Detergent (Linear alkyl benzyl sulfonate or LAS)	0.1%
Bacteriological	BOD not less than 700 ppm

1. Volumetric percentages of concentrated reagents of C.P. grade. Weight change specimens shall be 2 inches in diameter and may be molded discs or discs cut from the pipe wall. They shall be conditioned in a mechanical convection oven for 7 days at 11°F± 4°F, then cooled in a desiccator for 3 hours at 73°F± 4°F, weighed, and then immersed in the above solutions. At 28-day intervals selected specimens shall be removed, washed, surface dried and weighed. These same specimens shall be reconditioned in a mechanical convection oven for 7 days at 110°F± 4°F, then cooled in a desiccators for 3 hours at 73°F± 4°F and weighed again. If any specimen fails to meet these requirements at any time, the material will be rejected.

H. Installation Time Limit

The Contractor shall retest within 60 days prior to the installation of all pipe and fittings that are more than 180 days old from the date of manufacture to ensure compliance with the requirements of the Specifications. The Contractor shall not install any pipe that is more than 2 years old from the date of manufacture.

Polyvinyl chloride (PVC) pipe and fittings for sewers shall be in conformance with ASTM D3034 for SDR 35 or stronger, and shall be suitable for use as gravity sewer conduit. Provisions shall be made for contraction and expansion at each joint by means of a rubber ring. Glued joints are not acceptable. SDR 26 pipe is required at depths greater than 20'.

The bell shall consist of an integral wall section with a solid cross-section rubber ring. Rings shall be factory-assembled into bells, and shall be securely locked into place to prevent displacement during assembly.

All fittings shall be PVC as manufactured by the pipe supplier, and shall be designed for use with PVC sewer pipe.

PVC pipe shall be installed over a trench bedding designed to limit long term deflection to not more than five percent (5%). Design calculations shall be submitted to RCWD for review at least two weeks prior to the start of construction.

2.2.2 Prohibited Pipe Materials

The following pipe materials are not allowed for use in the construction of sanitary sewers:

- Asbestos Cement Pipe
- High Density Polyethylene
- (HDPE) High Density Polyethylene Plastic Pipe
- (PE) Polyethylene Solid Wall Pipe
- Concrete Truss Pipe
- Cement or Mortar Lined Ductile Iron Pipe
- Concrete Pipe (unlined or nonreinforced)

2.2.3 Manholes

Manholes for sanitary sewers shall conform to the *Standard Specification for Concrete Manholes*.

2.2.4 "Wye" and "Tee" Branches

The Contractor shall place "Wye" and "Tee" branches as shown on the Plans. "Wye" and "Tee" branches shall be installed at any angle not greater than 45° from the horizontal.

Each "Wye" or "Tee" branch, or the end of a sewer which does not terminate in a manhole, shall be closed at the bell with a cap made for that purpose.

2.2.5 Sewer House Branches

Sewer house branches shall be constructed of PVC, meeting the same specifications as given above for sanitary sewer mains.

Sewer house branches four (4) inches in diameter may be connected directly to sewer mains, providing that a machine core is used to connect to the sewer main. Such sewer house branches connected to sewer mains less than 18 inches in diameter require the use of "Wye" branches.

Sewer house branches six (6) inches and larger require a manhole at their point of connection with the main sewer, regardless of main size.

House branches shall be constructed at the locations shown on the Plans, from the point of connection to the sewer main to appoint approximately one (1) foot beyond the property line. The sewer house branch shall have a minimum depth of 36 inches at that point. House branches shall be installed in accordance with Standard Drawing S-4.

2.2.6 House Branch Plugs

Plugs used to seal the ends of house branches shall be of a type approved by the pipe manufacturer for use with his product.

2.2.7 House Branch Excavations

Excavations for laying house branches shall be in accordance with the earthwork provisions given below, and shall be performed in such a manner that at no time will closure of the street be required. Whenever house branches are to be installed in pavement, an encroachment permit from the Madera County Department of Public Works is required.

2.2.8 Curb Markings

The Contractor shall mark the location of the end of the house branch by chiseling an "S" mark on the curb face, if one exists..

2.3 Alignment

Pipes will be point to point with straight lines. No bending or pulling of joints is allowed. The pipe shall be wholly under the road section.

2.4 Excavation, Installation, and Backfill

2.4.1 General

This work shall consist of all excavation and backfill necessary for the construction of pipelines, structures and other facilities, and the restoration of surfaces disturbed by such work, all as set forth in the Plans and Specifications and as directed by the Engineer.

Excavations for appurtenance structures, such as manholes, transition structures, junction structures, vaults, etc., shall be deemed to be in the category of trench excavation.

All excavations shall be made in accordance with the trench construction safety orders issued by the Division of Industrial Safety of the State of California.

2.4.2 Trench and Structure Excavation

Excavations shall be made to the depths and widths required accommodating construction of conduits and structures to specified dimensions and to the lines and grades indicated on the Plans. Unless otherwise indicated on the Plans, excavations for pipe construction may be open cut.

The Contractor shall be responsible for locating and protecting subsurface obstructions in the field, and shall notify the Engineer immediately if conflicts occur. The location of subsurface obstructions found in the field may necessitate a variance in the depth or alignment of proposed facilities.

The Contractor shall perform all excavations in accordance with the Trench Construction Safety Orders issued by the Division of Industrial Safety of the Department of Industrial Relations of the State of California.

When a trench or structure site is to be located in an existing oiled earth or pavement area, the existing surfacing to be removed shall be cut by methods approved by the Engineer along neat lines on each side of the trench or around the structure site. Existing surfacing, when removed, shall be kept separated from the material that is to be returned to the excavation. Failure to comply with this requirement shall be grounds for rejection of the contained material for use as backfill.

Material excavated from the trench shall be placed so as to offer minimum obstructions to traffic.

All existing gas pipes, water pipes, conduits, sewers, drains, fire hydrants, and other structures which are not, in the opinion of the Engineer, required to be changed in location shall be carefully supported and protected from injury by the Contractor; and in case of

injury, they shall be restored by him, without additional compensation, to as good a condition as that in which they were found.

The Contractor shall provide, without additional compensation, suitable temporary channels for the water that may flow along or across the site of the work when necessary.

If all excavated material cannot be stored on the roadway in such a manner as to maintain access to property along side of the work, the surplus material shall be removed from the work and stored until needed for backfill at which time it shall be brought back. If the surplus material is to be stored on other than private property, prior approval must be obtained from the Engineer for the site to be used. The cost of removing and returning material shall be by Contractor.

2.4.3 Trench Bottom

The trench bottom shall be graded to provide a smooth, firm, and stable foundation at every point throughout the length of pipe. The Contractor shall use a laser grade device to ensure that the trench bottom is accurately and correctly graded. Alternative methods must be approved by RCWD prior to the start of construction.

At each joint in the pipe, the bottom of the trench shall be recessed in the firm foundation in such a manner as to relieve the bell of the pipe of all load, and to insure continuous bearing along the pipe barrel upon the firm foundation. Should large gravel and cobbles be encountered at the trench bottom or pipe sub-grade, they shall be removed from beneath the pipe and replaced with clean imported sand which shall be compacted to provide uniform support and a firm foundation.

2.4.4 Trench Width

Trenches shall conform to the dimensions in Details D-1, D-2, S-1, S-2, W-1 and W-2 unless otherwise specified in the Special Provision, indicated on the Plans, and as may be approved by the Engineer.

If the maximum trench width as specified is exceeded at the top of the pipe the Contractor shall provide, at no additional cost to RCWD, the necessary additional load bearing capacity by means of bedding, having a higher bedding factor than that specified, higher strength pipe, a concrete cradle, cap or encasement, or by other means approved in writing by the Engineer.

If the Contractor is unable to maintain the trench widths specified above, the District's Representative shall specify an additional bedding requirement to compensate for the additional loading on the pipe. Such additional bedding may require crushed or natural rock or other suitable granular bedding material as necessary to provide satisfactory pipe support, which shall be supplied.

2.4.5 Trench Grade

Alignment and elevation stakes shall be furnished to the Contractor at set intervals and agreed upon offsets. Where elevation stakes are furnished, the Engineer will also furnish the Contractor with cut sheets.

For all pipe 12 inches or greater in diameter, the Contractor shall excavate for and provide an initial granular bedding at least 4 inches thick. This bedding material shall be placed at a uniform density with minimum compaction and fine graded as specified below.

Bell or coupling holes shall be dug after the trench bottom has been graded. Such holes shall be of sufficient width to provide ample room for caulking, banding, or bolting. Holes shall be excavated only as necessary to permit accurate work in the making of the joints and to insure that the pipe will rest upon the prepared bottom of the trench, and not be supported by any portion of the joint.

Depressions for joints, other than bell-and-spigot, shall be made in accordance with the recommendations of the joint manufacturer for the particular joint used.

2.4.6 Fine Grading

Unless otherwise specified in the plans and/or special provisions, the bottom of the trench shall be accurately graded to provide uniform bearing and support for each section of the pipe at every point along its entire length, except for portions of the pipe where it is necessary to excavate for bells and for proper sealing of the pipe joints.

2.4.7 Over-excavation

Except at locations where excavation of rock, hardpan, or other unsuitable material from the bottom of the trench is required, care shall be taken not to excavate below the depth indicated.

Unauthorized excavation below the specified grade line shall be refilled by Contractor with an approved granular material compacted to a uniform density of not less than 90 percent of the maximum density as determined by ASTM D1557 and D3017.

Whenever rock or hardpan material is encountered in the trench bottom, it shall be over-excavated to a minimum depth of four inches below the O.D. of the pipe. This over-excavation shall be filled with washed concrete sand material placed with the minimum possible compaction.

Excavation for Manholes, Valves, Inlets, Catch Basins and Other Accessories Structures shall be over-excavation at least twelve inches (12") beyond dimensions of structures as shown on the plans. If the native material is such that it will not stand without sloughing or if precast structures are used, the Contractor shall over-excavate to place the structure and this over-excavation shall be backfilled with the same material required for the adjoining pipe line trench.

2.4.8 Pavement and Concrete Cutting and Removal

Where trenches lie within the Portland cement concrete section of streets, alleys, driveways, or sidewalks, etc., such concrete shall be saw cut to neat, vertical true lines in such a manner that the adjoining surface will not be damaged. The minimum depth of cut shall be 1 ½ inches or 1/4 of the thickness, whichever is greater.

No ripping or rooting will be permitted outside limits of cuts. Surfacing material removed shall be hauled from the job site immediately, and will not be permitted in the backfill.

Asphalt ground edge is acceptable and saw cutting will not be required.

2.4.9 Grading and Stockpiling

All grading in the vicinity of trench excavation shall be controlled to prevent surface water from flowing into the trenches. Any water accumulated in the trenches shall be removed by pumping or by other approved methods.

During excavation, material suitable for backfilling shall be piled in an orderly manner, a sufficient distance back from the edges of trenches, to avoid overloading and to prevent slides or cave-ins. Material unsuitable for backfilling, or excess material, shall be hauled from the job site and disposed of by the Contractor.

The Contractor shall, prior to final acceptance of the work, submit a letter to RCWD stating the location of each disposal site for all excess or unsuitable material and certify that he has obtained the property owner's permission for the disposal of all such materials.

2.4.10 Open Trench

Except where otherwise noted in the special provisions, or approved in writing by the Engineer, trenches shall be excavated only as far in advance of pipe laying as can be backfilled in the same day. The maximum total length of open trench shall be 1,000', except where approved in writing by the District Engineer.

Any excavated area shall be considered open trench until all aggregate sub-base material for pavement replacement has been placed and compacted. With the approval of the engineer, pipe laying may be carried on at more than one separate location, the restrictions on open trench applying to each location. Trenches across streets shall be completely backfilled as soon as possible after pipe laying.

Substantial steel plates with adequate trench bracing shall be used to bridge across trenches at street crossings where trench backfill and temporary patches have not been completed during regular work hours. Safe and convenient passage for pedestrians shall be provided. The Engineer may designate a passage to be provided at any point he/she deems necessary. Access to hospitals, fire stations and fire hydrants must be maintained at all times.

2.4.11 Foundations in Poor Soil

If excessively wet, soft, spongy, unstable, or similarly unsuitable material is encountered at the subgrade it shall be removed and replaced by crushed rock, gravel, or 2.5 sack cement slurry of sufficient thickness to form an unyielding foundation.

2.4.12 Existing Utilities

All existing gas pipes, water pipes, conduits, sewers, drains, fire hydrants, and other structures which are not, in the opinion of the District's Representative, required to be relocated, are to be carefully supported and protected from injury by the Contractor. If such improvements are harmed in any way, they shall be repaired to their original condition by the Contractor.

2.4.13 Installation

Proper facilities shall be provided for stringing and lowering sections of pipe into the trench. The pipe shall be laid carefully to lines and grades given.

The grade line shown on the plans indicates the flow line or invert of the pipe and all cuts, unless otherwise indicated, refer to this line. After the trench for pipe has been brought to the proper line and grade, the pipe shall be laid in the following manner:

Pipe laying shall begin at existing sewer locations and shall proceed upgrade with the bell or groove end of the pipe placed upstream. Each section of pipe shall be laid true to line

and grade and in such a manner as to form a watertight, concentric joint with the adjoining pipe. Existing sewer lines and flow therein shall remain operational at all times. Any rerouting or blockage of sewer flows during construction, by the Contractor, shall require approval by the District Engineer.

Sewer pipe and fittings shall be laid and jointed in compliance with the manufacturer's recommendation and shall be carefully adjusted to grade by scraping of filling and tamping the trench bottom. Each joint of pipe must be fully pressed into place so that there will be no unevenness or settlement of one length of pipe with the other at the joint.

Circular reinforced concrete pipe with elliptical reinforcement shall be placed with the minor axis of the reinforcement in a vertical position.

The Contractor shall furnish and use, for grade and alignment control, a laser beam system which complies with OSHA requirements. The laser system shall have good visibility when used with suitable target material. The laser system must be of the self-leveling type so that the laser beam is automatically compensated for minute grade disturbances.

The laser system must also have an early warning system that instantly warns the pipe layer when the laser is off grade. The laser system is to be provided by the Contractor and shall have a minimum accuracy of ± 0.01 foot per one hundred feet (100') on line; and a minimum visible range of one thousand feet (1000'). When conditions are such that this method is impractical, such as on short pipe runs, the Contractor shall have an Engineer on the ground to set grade of each joint of pipe by means of an Engineer's level.

The grade line shown on the Plans indicates the flow line or invert of the pipe and all cuts, unless otherwise indicated, refer to this line.

Each joint of pipe must be fully pressed into place so that there will be no unevenness or settlement of one length of pipe with the other at the joint.

The interior of the pipe shall be kept free from dirt, excess mortar and other foreign material as the laying progresses. Pipe shall not be laid when the condition of the trench or the weather is unsuitable, in the opinion of the Engineer, because of water or mud which may interfere with proper jointing. All open ends of pipe and fittings shall be adequately and securely closed whenever the work is discontinued. Any pipe which shows undue settlement or is damaged shall be taken up and replaced or re-laid by Contractor.

All pipes shall be laid to true line and grade. Occasional variations as follows will be permitted:

Above grade, 5mm (1/4 inch); below grade, not to exceed 10mm (1/2 inch); alignment not to exceed 50mm (2 inches) if gradual and regular over a distance of 6m (20 feet).

2.4.14 Grade Tolerance

All pipes shall be laid true to line and grade. Occasional variations will be allowed as follows:

Vertical	1/2"
Horizontal	2"

Tolerances given are the maximum allowable deflections if gradual and regular over a distance of 20 feet or more.

2.4.15 Backfilling

At the option of the Contractor, backfilling may be completed prior to leakage tests or infiltration tests. After the pipe has been properly laid and inspected, the trench shall be backfilled to a height of one foot (1') above the top of the pipe with selected material which shall be sand or fine earth, free from clods, lumps, stones, or clay. This material shall be compacted to a density of ninety percent (90%) or more, by means of tamping or water settling, depending upon the nature of the material. When the soil is of a sandy nature flooding may be allowed, depending on the level of natural groundwater, completely saturating and settling the material. If the material is not of a granular nature, it shall be brought to optimum moisture content, placed in layers not exceeding six inches (6") in thickness, and each layer compacted by means of hand tampers or pneumatic tampers.

Material excavated from the trench may be used for backfill from a point one foot (1') above the pipe to the finished grade, provided that such material be free of vegetation, organic material, asphaltic pavement and other debris, and contains no stones or solids of greater than eight inches (8") in diameter and no material of a spongy or perishable nature. The backfill material shall be compacted to a density of ninety percent (90%) or more. Either tamping or water settling may be used, unless the District's Representative directs that water settling not be used due to the presence of high groundwater.

2.4.16 Pipe Embedment Zone

Pipe Embedment Zone shall be defined as that material supporting, surrounding, and extending to 0.3m (12") above the top of the pipe. Material used for backfilling within the Pipe Embedment Zone shall consist of the following select natural material or processed product Class II or Class III material as defined herein and shall be compacted to a minimum 90% as determined by ASTM D1557 (latest editions).

Class II: (E'= 3000 psi)* Washed concrete sand conforming to Caltrans Section 90-3.03.

Class III: (E'= 2000 psi)* Select natural sand and coarse silty sand conforming to the following particle size gradation and sand equivalent:

Sieve Size	Percent Passing
19 mm (3/4")	100
4.75 mm (#4)	> 50
(#200)	35 Maximum
Sand Equivalent	20 Minimum

2.4.17 Initial Backfill

Initial backfill shall be the material between the top of the bedding material and 0.3m (12") above the top of the pipe.

Initial Backfill shall consist of placing and firmly compacting selected granular backfill material under the haunches of the pipe and up to the spring-line of the pipe, and then filling to a level 300mm (12") above the top of pipe

Initial backfill shall be placed immediately after the pipe has been laid to line and grade in the trench, inspected and passed by the Engineer. The material shall be carefully placed so as not to disturb or damage the pipe or its placement, and shall be brought up evenly on both sides. Initial backfill material shall be backfilled to one foot (1') above the top of the pipe, in layers not to exceed eight inches (8") in depth and tamped by hand or pneumatic tampers to a relative compaction of 90% as determined by ASTM D1557.

The method of compacting and obtaining density requirements for all pipe trenches shall be such that the backfill material shall be completely compacted around the lower haunches of the pipe, such that line and grade of the pipe is not disturbed, and the pipe is not damaged.

2.4.18 Jetted Backfill

- Jetting will be permitted when at minimum, the backfill and the sidewall native soils in the lower one-third of the trench depth are self-draining and possess a sand equivalent of not less than 20. Jetting shall be accomplished by the use of a jet pipe to which a hose is attached, carrying a continuous supply of water under pressure.

Backfill shall be jetted in accordance with the following requirements:

1. The jet pipe shall consist of a minimum 1 ½" diameter pipe to which a minimum 2" diameter hose is attached at the upper end. The jet shall be of sufficient length to project to within 2 feet of the bottom of the lift being densified.
2. The Contractor shall jet to within 2 feet of the bottom of the lift and apply water in a manner, quantity and at a rate sufficient to thoroughly saturate the thickness of the lift being densified. The jet pipe shall not be moved until the backfill has collapsed and the water has been forced to the surface.
3. The lift of backfill shall not exceed that which can be readily densified by jetting, but in no case shall the undensified lift exceed 10 feet.
4. Suitable backfill material to be jetted shall have a sand equivalent of 20 or greater.
5. Where the nature of the material excavated from the trench is generally unsuitable for jetting, the Contractor may, at no cost to the Agency, import from an approved source suitable material for jetting or densify the excavated material by other methods as approved by the Engineer. The backfill shall be allowed to thoroughly drain until the surface of the backfill is in a firm and unyielding condition prior to commencement of any subsequent improvements. The Engineer may require the Contractor, to dig a sump and provide a sump to remove any accumulated water.
6. The Contractor shall make its own determination that jetting will not result in damage to adjacent structures or facilities. Any resulting damage shall be repaired by Contractor.
7. The Contractor shall have available a continuous supply of water at a minimum pressure of 40 psig. If a water truck is used to supply water, it shall have a pump capable of supplying water at 40 psig and shall have the capacity to jet the trench without refill.

8. Once jetting has occurred, the fill shall be compacted with a “hydrahammer” drop weight type of compactor. The backfill depth shall not exceed the capacity of the compacting device in achieving 90% percent compaction in a single lift or 10 feet, whichever is less, the compaction in the top 2' shall be 95%.

2.4.19 Final Backfill

Final Backfill shall be the material above the Initial Backfill and consist of sound earthen material which is free of all rocks, hardpan, paving material, organic matter, broken concrete, wood or other deleterious material. Unless otherwise specified, this may be selected native material with no piece larger than 50mm (2").

Backfilling of trenches shall be accomplished and constructed per Standard Drawing S-1 and S-2 with the type of replacement noted on the plans or in the special provisions. Surface restoration shall be accomplished and constructed per Standard Drawing No. ST-4, unless defined otherwise by Madera County encroachment permit.

Backfilling of trenches above the initial backfill as indicated in Section 2.4.15 above shall be as follows;

Where mechanical compaction is used, the moisture content shall be such that the specified compaction can be obtained and the backfill shall be placed in lifts the height of which shall not exceed that which can be effectively compacted depending on the type of material, type of equipment and methods used, and under no circumstances shall exceed 4 feet.

All backfill shall have a relative compaction of 90% to within twenty-four inches (24") of the surface and the top twenty-four inches (24") shall have a relative compaction of 95%. Test Method ASTM D1557 shall be used to determine relative compaction, using the dry random sampling method (dry weight basis).

No free water will be allowed in the top twenty-four inches (24") of backfill.

Backfill, around utilities that are exposed during trench excavation, shall be placed in accordance with the above bedding, backfill, and compaction methods.

3 STANDARD SPECIFICATIONS FOR CONCRETE MANHOLES

3.1 General

Concrete manholes shall be constructed in accordance with the design, size and details, and at the locations shown on the Plans. The manholes shall be constructed of precast concentric or eccentric concrete manhole units in accordance with the Plans and these Specifications.

3.2 Materials and Workmanship

3.2.1 Excavation and Backfill

Excavation and backfill shall be done in accordance with the provisions of the *Standard Specifications for Earthwork (Pipelines)* of these Specifications.

3.2.2 Concrete

All concrete used in the construction of manholes shall be Class ``A" and conform to the provisions of the *Standard Specifications for Portland Cement Concrete* in these Specifications.

3.2.3 Mortar

Mortar used in manholes shall be composed of one part Type II Portland cement and two parts sand. Addition of hydrated lime or fire clay for workability shall not exceed 20% of the cement content.

3.3 Construction

3.3.1 Precast Manholes

Precast manholes shall conform to the size, shape, form, and details shown on the Plans. Concrete for precast manhole units shall be Class ``A." The precast cylinder units, the precast concrete taper sections and precast concentric flat-top sections shall meet the strength requirements for Precast Reinforced Concrete Manhole Risers and Tops (ASTM Specifications, designation C478). The minimum allowable steel shall be hoops of No. 4 wire, to be cast into each unit at adequate places as a precautionary measure for handling. Each manhole section shall be set in a bed of mortar to make a watertight joint, shall be neatly pointed on the inside, and shall be set perfectly plumb. Sections of various heights shall be used in order to bring the top of the manhole ring and cover to the elevation established on the Plans or by the District's Representative.

The precast concrete manhole rings shall be jointed with a minimum thickness of one-half inch (1/2") of Portland cement mortar. Mortar shall be comprised of one (1) part Portland cement to two (2) parts of clean, well-graded sand with one-hundred percent (100%) passing a number eight (8) sieve. Cement, aggregate, and water for mortar shall conform to the applicable provisions of the *Standard Specifications for Portland Cement Concrete* of these Specifications.

3.3.2 Manhole Bases

Manhole bases shall be constructed of Class ``A" concrete to the form and dimensions shown on the Plans. Said precast concrete bases shall be placed on undisturbed soil and/or gravel sub-base as called for on the Plans.

3.3.3 Manhole Frames and Covers

Manhole frame and cover sets of the type, size, and quality indicated on the Plans shall be installed at the locations shown.

Casting for frame and cover sets shall conform to the requirements for Gray Iron Castings in ASTM A48 for Class No. 30 Castings. Before leaving the foundry, all casting shall be thoroughly cleaned and subjected to a hammer inspection, after which they shall be dipped twice in a preparation of asphalt, or coal tar and oil, applied at a temperature of not less than two-hundred-ninety degrees (290°) Fahrenheit, and in such a manner as to form a firm and tenacious coating. Each cover shall be ground or otherwise finished so that it will fit in its frame without rocking. Frames and covers shall be match-marked in sets before shipping to the site. Covers shall be identified as shown in Standard Drawing No. D-6. or S-6,

3.3.4 Setting Manhole Frames and Covers

The elevations at which manhole frames and covers are to be set shall conform to the requirements set forth on the Plans, but in all cases shall be governed by the District's Representative in the field. Where the cover is in existing pavement or in the traveled way of the existing road shoulder, it is to be placed flush with the existing surface, per Standard Drawing No. D-4 or D-5 or S-5. Where the structure is outside the limits of the traveled shoulder but not in the roadside ditch, it should be placed 0.50-foot or more above the existing ground surface. Where the manhole cover falls in the existing roadside ditch or right-of-way, it is to be placed approximately one and one-half feet (1-1/2') above the existing ground surface or as directed by the District's Representative. Manhole frames shall be set at the required grade and shall be securely attached to the top of the precast manhole shaft unit with a cement mortar bed as shown on the Plans. After the frames are securely set in the place provided therein, covers shall be installed and all necessary cleaning and scraping of foreign materials from the frames and covers shall be accomplished to insure a fine satisfactory fit.

3.3.5 Pavement Removal and Resurfacing

Resurfacing of all excavations for construction of manholes shall conform to the provisions of the Standard Specifications and Standard Drawings D-4 or D-5 or S-5.

3.3.6 Water-tightness of Manholes

It is the intent of the Plans and Specifications that manholes and appurtenances are as watertight and free from infiltration as possible. Where manholes are to be given a protective lining and coating, they shall be free of *any* seeping or surface moisture. The adequacy of manholes and appurtenances as to water-tightness shall be determined by the District's Representative, and shall be tested by filling with water when ordered by the District's Representative. Any evidence of leakage shall be repaired to the satisfaction of the District's Representative at the sole expense of the Contractor.

4 STANDARD SPECIFICATION FOR TESTING OF SANITARY SEWERS

4.1 General

- 4.1.1 All testing and inspection shall be performed after final backfill and compaction operations and joint trench or other utilities are complete and base rock (AB) have been placed but not necessarily finish graded. If the Contractor so desires, he may pretest the lines at his own expense, but final testing must be performed after compaction requirements have been approved. If joint trench sleeved crossings are installed and the remainder of joint trench is installed after base rock and paving are completed the testing identified above shall be retested upon completion of the joint trench.
- 4.1.2 If any of the tests or inspections covered in this section indicates that pipe requires repair, then after repairs are complete, all testing and inspection shall be performed again, at the Contractor's expense.
- 4.1.3 Prior to testing, all lines shall be thoroughly cleaned by flushing.
- 4.1.4 Cost of all testing shall be included as a part of Contractors work.

4.2 Mandrel Test

- 4.2.1 All sections of completed gravity pipe main lines shall be tested to assure that no potential obstructions are present in the lines. A rigid mandrel with a circular cross section having a diameter not less than 95% of the specified pipe diameter shall pass through the pipe without resistance.

4.3 Low-Pressure Air Test

Prior to testing, all lines shall be thoroughly cleaned by flushing. All sanitary sewers shall be air-tested.

Step One

Each test section shall be plugged at each end and at each lateral, stub, and fitting. One plug shall be equipped with an air inlet connection for filling the line with compressed air.

Step Two

Fill each test section with air to a pressure of 3.5 psig using a portable air test equipment kit including a shutoff valve, pressure regulating valve, and pressure gage having minimum divisions of 0.50 psi or finer.

Step Three

When a constant pressure of 3.5 psig is reached, throttle the air supply, and maintain an internal pressure of at least 3.0 psig for at least five (5) minutes.

Step Four

With a watch, determine the time required for pressure to drop from 3.0 to 2.5 psig using the following formula.

The minimum allowable time in minutes for such a pressure drop is determined from the formula $T_{min} = 0.000183D^2L$, where:

- D = Nominal Inside diameter of pipe (inches)
- L = Length of Pipe Test Section (feet)

If the diameter of the pipe system is not consistent, the effective diameter (D_{eff}) shall be calculated as follows:

$$D_{eff} = \sqrt{D_1^2 L_1 + D_2^2 L_2} / L_1 + L_2$$

4.3.1 Minimum Test Time

The minimum time allowed for pressure drop shall be ten (10) minutes, even if the formula provides a lesser time requirement.

4.3.2 Adjustment of Pressure for Groundwater

Should the pipe section being tested lie below the local groundwater table, the test pressures shall be raised in proportion to the depth of the centerline of the pipe below the water table. Additional pressure (beyond the 3.5 psig specified above) shall be added at the rate of 0.433 psig per foot of depth below groundwater.

4.3.3 Corrective Measures

Failure of a section of pipe to pass the low-pressure air test shall be taken as evidence that a fault exists in the test section. It shall be the Contractor's responsibility to repair the section to the point where an air test can be successfully conducted. The District's Representative may require performance of a video inspection in accordance with Section 4.4 of this Standard Specification in order to attempt to pinpoint the area of failure. Such test shall be taken by Contractor. Failure of the video inspection to isolate the problem area shall not relieve the Contractor of his responsibility to repair the line.

4.4 Video Inspection

Video inspection of new sewer mains is required in all new installations. Such inspection will be arranged by the District's Representative. Video inspections shall be paid for by the Contractor and shall be completed prior to the final acceptance of the improvements. The inspection shall be in color, and shall be recorded DVD Format Disk, USB Thumb drive or an approved alternative, which shall become the property of RCWD.

RCWD shall be the sole judge as to the acceptability of construction revealed by such inspection. If there are areas of pipeline not within the allowable grade tolerance, or if the inspection reveals holes or leaks in the pipeline, the Contractor will be so notified, and will be responsible to make needed repairs. RCWD will not advise the Contractor as to recommended procedures, but will limit its comments to the acceptability of the end product.

If video inspection reveals faults such as dirty pipe or fittings, broken pipe, over or under stabbed pipe or fitting joints, PVC burrs at pipe or fitting joints, misalignment, or improper grades, such faulty areas shall be promptly removed and replaced by the Contractor. Both the video inspection and subsequent repairs shall be made by Contractor. If sewers require repair then all testing and inspection must be performed again by Contractor.

4.4.1 Requirement for Sewer Video inspections:

- The testing Company is to certify as to their ability to adequately perform the video inspection.
- The District Inspector will be provided 24 hour notice of testing schedule and will be present to monitor the test.
- A flush truck will be required to be on-site to aid in the video inspection.
- A video tape shall be submitted to RCWD as proof of inspection and be certified to comply with plan requirements or pointing out by station any defects found.
- Manholes to be documented from center line of starting manhole to center line of terminating manhole and include rubber boot or grouted connection detail.
- Lateral lines to be documented by stationing from center line of manhole and the testing firm shall provide a map of the tested lines.
- A chronological log of the test performed should correlate between the sewer plans and the tape produced.

4.4.2 Measurement

Measurement for sewer main installation and service lateral installation shall be by the lineal feet of pipe installed, and shall be the actual horizontal length installed, measured through wye fittings.

Measurement for wye or Tee fittings shall be per each wye or Tee fitting installed. Measurement for manholes shall be per each manhole installed.

5 STANDARD SPECIFICATION FOR SEWER LIFT STATIONS

5.1 General

These Specifications designate the requirements for design and construction of wet-pit lift stations for sanitary sewage collection. Prior to construction, the engineer of the work shall submit calculations for approval by RCWD, as listed below.

Lift station design shall be duplex or triplex using submersible pumps. Pumps shall be Flygt N-Pump or approved equal, equipped with self-cleaning impellers.

The system shall include pumps and a slide rail/ disconnect system designed to allow removal and reinstallation of the pumps without need for personnel entry into the wet well. All components of the pumping system shall be of common manufacture, and shall be listed and labeled by Underwriter's Laboratory (UL) or Factory Mutual (FM) for operation in a Class 1, Group D, and Division 1 location as defined in Section 501-8 of the National Electrical Code. The Developer-Contractor shall assign unit responsibility to the pump supplier or manufacturer for the equipment specified in this section in order to enhance compatibility, ease of construction, and efficient maintenance of the components of each pumping system. The pump manufacturer shall coordinate pump controls so that a complete and operable system is achieved.

5.2 Minimum General Requirements

All stations shall be a duplex at minimum.

All stations shall be designed as submersible non-clog lift stations complete with paved access drive, maintenance friendly layout and grading, motors, permanent discharge elbows, guide bars, intermediate, upper and lower guide bar brackets, power cables, lifting chains, pump controls, level sensor, generator, lighting and pole, yard hydrant, anchor bolts, valve vault, wetwell, aluminum/FRP access hatch, fenced site work, spare parts and other accessories including all necessary labor, supervision, materials, tools, and appurtenances.

Minimum wetwell diameter shall be 10-feet.

Wetwell shall be coated with RCWD approved corrosion resistant coating.

Each station shall be furnished and installed with a permanent standby generator as approved by RCWD.

Each lift station shall be furnished and installed with RCWD's most current Supervisory Control And Data Acquisition (SCADA). Contact RCWD for the latest requirements.

SCADA shall monitor the following event : on-off –failure status of each pump, runtime for each pump, generator status-running or failure, high level alarm.

Check valves shall be weighted type.

All phases of construction shall be inspected as per RCWD's requirements.

5.3 Pump Equipment

5.3.1 General

Each lift station design and site is unique, and shall be reviewed by RCWD as such. This includes site layout, access, electrical requirements, appearance, controls, etc. These standards are presented as a minimum requirement and guideline only; changes or additional requirements to each station may be required by RCWD at their discretion as a result of review during plan submittals and/or construction.

5.3.2 Pump Requirements

Pumps shall be the submersible type specifically designed for pumping raw sewage containing solids and stringy materials. The pumps shall be capable of handling raw, unscreened sewage while running in a continuous submerged condition to a depth of 65 feet. Pumps shall pass a minimum three (3) inch solid. The pump shall operate without clogging or fouling caused by materials in the pumped fluid at any operating condition within the range of service specified. The pump shall be designed to operate without cavitation over the full range of operating conditions. The pump head-capacity curve shall slope in one continuous curve with no point of reverse slope inflection. Pumps shall be designed for continuous operation under submerged, partially submerged or totally dry conditions without damage to the pump or motor.

The complete pumping unit shall be designed to operate without overload on any component at any point along the pump's entire operating curve. Without derating the motor, the pumps shall be able to pump continuously with the minimum water level at the bottom of the motor housing, under full load, without the need of spray systems or air moving equipment. The motor horsepower shall be adequate so that each pump is non-overloading throughout its entire pump performance curve from shut-off through run-out.

Pumps to be installed at the locations described on the ENGINEER's plans shall be submersible centrifugal pumps, modified to provide the specified features and to meet the specified operating conditions.

5.3.3 MATERIALS OF CONSTRUCTION

As a minimum, materials employed for the construction of equipment provided under this specification shall be as follows:

Component	Material
Pump and motor casing	Cast iron, ASTM A48, Class 35
Discharge elbow	Cast iron, ASTM A48, Class 35
Impeller	Cast iron, ASTM A48, Class 35
Motor and pump shaft	Stainless steel ASTM A276, Series 416
Wearing ring	Nitrile or stainless steel, ASTM A276 Series 400
Externals bolts and nuts	Stainless steel, ASTM A276 Type 304
Guide bar brackets	Stainless steel, ASTM A276 Type 304
Guide bars, lifting chain and Hook assembly's Type 304	Stainless steel, type 316L and/or ASTM A276

All surfaces, excluding stainless steel or brass, shall be coated in accordance with the manufacturer's recommendations.

5.3.4 EQUIPMENT FEATURES

- GENERAL

Motor and rotating parts shall be removable from the motor end of pumps. All mating surfaces where watertight sealing is required shall be machined and fitted with Buna-N rubber O-rings. Pumps shall be fitted with dynamically balanced nonclog impellers designed to pass coarse solids and stringy materials. Major pump components shall have smooth surfaces devoid of blow holes or other irregularities. All external surfaces coming into contact with the pumpage, other than stainless steel or other corrosive resistant materials, shall be painted.

The pump discharge connection shall be permanently installed in the pump sump along with the discharge piping. Pumps shall be automatically and firmly connected to the discharge piping when lowered into place to the discharge connections. Pumps shall be easily removable for inspection or service, requiring no bolts, nuts, or other fastening to be removed for this purpose, and no need for personnel to enter pump well. Pumps shall be fitted with stainless steel chain of adequate strength and length to permit raising pumps for inspection and removal by the hoist. Sealing of the pumping unit to the discharge connections shall be accomplished by a simple linear downward motion of the pump with the entire weight of the pumping unit guided to and pressing tightly against the discharge connections. Sealing of the pumping unit to the discharge connection shall be accomplished by a machined

metal to metal watertight contact or a profile seal. The connection between the pump and discharge connection shall allow zero leakage.

No portion of the pump shall bear directly on the floor of the sump and no rotary motion of the pump shall be required for sealing. There is not more than one 90 degree bend allowed between the volute discharge flange and discharge piping. Guide bars, which shall steer the pump into proper contact with the discharge elbow shall be nonadjustable and shall not bear the weight of the pump.

- PUMP SHAFT

Pump and motor shaft shall be of the same unit. A surface finish with minimum roughness value of 12 micro-inches shall be required.

The shaft shall not extend or overhand more than 2 1/2 times its maximum diameter below the bottom support bearing. The pump shaft shall be completely isolated from the pumped media.

- BEARINGS

The pump shaft shall rotate three permanently lubricated bearings. The upper bearing, provided for radial forces, shall be a single roller or ball bearing. The two lower bearings shall consist of one roller or ball bearing for radial forces and one angular contact for axial thrust. Bearings shall be heavy-duty, oil lubricated or permanently greased lubricated type double shielded and factory sealed. Bearings shall be designed for an L-10 bearing life of a minimum 40,000 hours.

- IMPELLER

Impellers shall be dynamically balanced, double shrouded, non-clogging design capable of handling solids, fibrous materials, heavy sludge, and other matter found in normal sewage applications. Fit between the impeller and the shaft shall be a sliding fit with a tamper-lock bushing pressed by a screw which is threaded into the end of the shaft, or a slip fit onto the shaft and drive key and fastened to the shaft by an impeller nut having cover for protection from pumped fluid. A wearing ring system designed for abrasion resistance shall provide efficient scaling between the volute and impeller. All impellers and interior surfaces of pump shall be coated with a factory applied acrylic compound or high solids content epoxy, resistant to wastewater.

- MECHANICAL SEALS AND WEARING RINGS

Each pump shall be provided with a tandem mechanical shaft seal system consisting of two totally independent seal assemblies. The seals shall operate in an oil reservoir that hydro dynamically lubricates the solid block seal faces at a constant rate. The lower, primary seal unit, between the pump and oil chamber, shall consist of one stationary and one positively driven, rotating silicon-carbide or tungsten-carbide ring, with each pair of rings held in contact by a separate springs. The upper, secondary seal unit, between the oil sump and the motor housing, shall consist of one stationary silicon-carbide or tungsten-carbide seal ring AND one positively driven rotating silicon or tungsten-carbide seal ring. Ceramic seals will not be acceptable. The seals shall require neither maintenance nor adjustment and shall be easily replaceable and commercially available. Conventional double mechanical seals with a single or a double spring between the mating faces, or that

require constant differential pressure to affect sealing or are subject to opening and penetration by pumping forces, will not be acceptable. The submersible pumps shall be capable of continuous submergence without loss of watertight integrity to a depth of 65 feet.

A replaceable wear ring system shall be installed to provide efficient sealing between the volute and impeller. The wear ring shall consist of a brass ring insert and is press-fitted to the volute inlet. A rotating wear ring, 420 or 431 stainless steel which is fitted to the impeller suction inlet shall be provided.

Each pump shall be provided with an oil chamber for the shaft sealing system, and have moisture detecting early warning probes installed. The oil chamber shall be designed to prevent overfilling and to provide oil expansion capacity. The drain and inspection plug, with positive anti-leak seal shall be easily accessible from the outside. The seal system shall not rely upon the pumped media for lubrication. The motor shall be able to operate dry without damage while pumping under load.

- CABLE SEAL

The flexible power cables for submersible pumps shall include an equipment grounding conductor to the submersible pump frame and shall be sized according to NEC and ICEA Standards. The power cable shall be of sufficient length to reach the junction box without any need of splices. The outer jacket of the cover shall be ethylene-propylene rubber. The cable entry water seal design shall preclude specific torque requirements to insure a watertight and submersible seal. The cable entry shall be comprised of a single cylindrical elastomer grommet having a close tolerance fit against the cable outside diameter and the entry inside diameter and compressed by the entry containing a strain relief function, separate from the function of sealing the cable. The assembly shall provide ease of changing the cable when necessary using the same entry seal. The cable entry junction chamber and motor shall be separated by a terminal board, which shall isolate the motor interior from foreign material gaining access through the pump top. The cable entry design shall be of the non-wicking type so moisture does not enter the cap if the cable is damaged in any way.

- MOTOR

The pumps shall be driven by a completely sealed submersible type, explosion-proof, air cooled, watertight, electric motor designed for operation up to 104 degrees F. ambient. The pump motors shall be a squirrel-cage induction, shell type design, housed in an air-filled watertight chamber, NEMA B type. The stator winding and stator leads shall be insulated with moisture resistant Class H insulation. The motors shall be designed for continuous duty handling pumped media and capable of sustaining a minimum of 15 starts per hour. The temperature rise of the motors shall not be in excess of that specified in NEMA MG-1 or equal for class B insulating materials when operating continuously under load. The stator shall be insulated by the triple impregnation method using Class II monomer-free polyester resin resulting in a winding fill factor of at least 95%. The junction chamber, containing the terminal board, shall be hermetically sealed from the motor. Connection between the cable conductors and stator leads shall be made

with threaded compressed type binding post permanently affixed to a terminal board. Wire nuts or crimping type connection devices are not acceptable. The submersible electrical cable shall be of sufficient length to reach the control panel. The motors and cables shall be capable of continuous submergence underwater without losses of watertight integrity to a depth of 65 feet. The motor and pump shall be designed by the same manufacturer.

The combined service factor (combined effect of voltage, frequency and specific gravity) shall be a minimum of 1.15. The motor shall have a voltage tolerance of plus or minus 10%. The motor shall be designed for operation up to 104° F (40° C) ambient and with a temperature rise not to exceed 176° F (80° C), and shall be rated in strict accordance with NEMA and SWPA standards.

A performance chart shall be provided showing curves for torque, current, power factor, input/output kW and efficiency. This chart shall also include data on starting and no-load characteristics.

An electronic moisture detection system shall be provided in each pump. The leakage sensor shall be located in the motor housing and wired through the junction box to the control panel. Any indication of moisture present shall activate a visual warning that leakage has occurred.

- COOLING SYSTEM AND MOTOR PROTECTION

Each pump shall be provided with a cooling system for continuous pump operation in liquid temperature of up to 104° F. The cooling systems for each pump shall consist of a water jacket encircling the stator housing. Impeller back vanes shall provide the necessary circulation of the cooling liquid through the water jacket. The cooling media channels and ports shall be non-clogging by virtue of their dimensions.

The motor protection systems shall consist of thermal and leakage sensors. The stator in each pump shall be equipped with three thermal switches to monitor stator temperature and protect the pump from overheating. The thermal switches shall be embedded in the end coils of the stator winding (one switch in each stator phase) and shall be used in conjunction with external motor overload protection and wired to the control panel. Should high temperature occur, the thermal switches shall open and activate an alarm.

The lower bearing housing in each pump shall include an independent thermal sensor to monitor the bearing temperature. If a high temperature occurs, the sensor shall activate an alarm.

A leakage sensor shall be available to detect water **in** the stator chambers. The monitoring system shall consist of the float switch which when activated; the sensor shall activate an alarm.

Submersible electrical cables of sufficient length to reach control panel shall be provided from thermal and leakage sensors.

5.3.5 Operating Conditions

For maximum efficiency, each impeller shall be trimmed to meet the specified system head and discharge conditions. Impellers shall be self-cleaning, clog-resistant, designed for use with raw, unscreened domestic sewage.

5.4 Pump Disconnect and Guide Rail System

The pumps shall be provided with a guide system to allow easy removal of the pumps without entering the wet well. The pumps shall automatically connect to the discharge piping when lowered into place, without need for latching or tightening of bolts. Each pump shall attach to a sliding guide bracket. Two guide bars shall be provided extending from the top slab of the lift station to the discharge connection of each pump and shall assist in raising and lowering the pump unit. The discharge connection shall be bolted to the floor and shall serve as a lower attachment for the guide bars. The working load of the lifting system shall be 50% greater than the pump unit weight.

Discharge elbow shall be cast iron and shall be located at the floor of the wet well. Receiving edge of the discharge elbow shall be constructed of non-sparking material and fitted with a resilient seal to provide a positive, leak-proof connection between pump and elbow.

The pump unit shall be guided on the bars by a guide bracket which shall be an integral part of the pump. Each pump shall be fitted with sufficient length of stainless steel wire rope capable of lifting the pump and motor. The guide system shall also include the "grip eye" lift and slings. The necessary fittings and eye bolts shall be provided. The guide system shall be fully warranted for 1 year.

All components of the quick disconnect and rail system shall be of common manufacture, and shall be listed and labeled by Underwriter's Laboratory (UL) or Factory Mutual (FM) for operation in a Class 1, Group D, and Division 1 location as defined in Section 501-8 of the National Electrical Code.

5.5 Electrical Controls

5.5.1 Electrical Equipment

All controls shall be mounted in a NEMA 4 metal enclosure with lockable dead front. The control panel and all electrical components shall bear the Underwriter's laboratory (UL) or Factory Mutual (FM) label. All circuit breakers shall have operators extending through the door of the enclosure.

5.5.2 Pump Control Panel

- A NEMA-4X watertight stainless steel control panel shall be provided. The control panel shall be fabricated in a UL508 recognized facility.
- The pump control panel shall be constructed to be compliant with the applicable sections of Article 430 of the latest version of the National Electrical Code (NEC). The panel shall be installed per the requirements of the relevant sections of the NEC.

- The wet well is considered a Class I Division 1 environment. As such, all conduits emanating from the wet well should be installed per the NEC code which deals with Class I Division I environments. This includes, but is not limited to, sealing the conduit before it enters the motor control panel.
- The pump control panel shall be equipped with an integral service disconnect which removes primary power from the panel. The control panel shall contain a sub-panel which separates the operator from the high voltage / current circuitry. The panel shall be constructed to provide an interlocking mechanism between the panel disconnect and the sub-panel which prevents the sub-panel from opening unless the disconnect is in the off position. The service disconnect may also provide the motor branch circuit overload protection (i.e., it may be a circuit breaker which doubles as a disconnect switch).
- The incoming service to the control panel shall be based on the power requirements of the pump motors. Three phase induction motors are typically specified for the pump motors so three phase power should be specified for the site. In cases where single phase power is all that is available, a single phase to 3 phase inverter or variable speed motor control unit shall be used. The contractor shall be responsible for contacting the local power company to specify and coordinate the installation of the required power feed.
- Pump motors rated at 301IP or greater shall be equipped with soft start circuitry.
- Provide three 120VAC, 20A, 1 pole circuit breakers in the pump control panel for town's use as shown on the electrical single line diagram drawing.
- Phase monitor shall be provided to sense low voltage and loss of power. Upon sensing any of these conditions, the pumps shall be stopped.
- Provide a weatherproof, shatterproof alarm light with 40-watt lamp and a horn mounted on the exterior of the control panel. The alarm will be sounded upon detection of a high level alarm in the wet well or in the event that all pumps are reporting a failed condition. (In general, the alarm shall be sounded based on any detectable condition which could result in a wet well overflow condition.) The alarm light shall flash until the alarm condition ceases to exist. A silence pushbutton shall be provided to silence the horn.
- The panel shall contain pump control logic which meets the specifications described in this section.

I. The logic shall be scalable to accommodate the number of pumps specified for the installation.

J. The logic shall interface to the specified level detection devices located in the wet well and activate the pump(s) based on a user selectable set point (water level).

K. The logic shall interface to the motor fault detection sensors (i.e., over temperature and moisture).

L. In multiple pump installations, the logic shall contain provisions to set a lead pump and to alternate between (or through) the available pumps in order to evenly distribute pump wear.

M. The control system shall have a self-contained switchboard device used to control the pump systems and alarms. Status information for pumps, pump fault, mode of operation, next pump to start, and level alarms shall be clearly indicated on the front display.

N. It is recommended that a Multitrode MT2PC or equivalent pump controller be used to implement these control functions.

- The pump control panel shall contain the following controls and indicators:

O. "Hand – Off- Auto" switch for each pump.

- The "Hand" position will force the pump to turn on unless operation is precluded due to a fault condition.
- The "Off" position disables the pump. Power cannot be applied to the pump with the switch in this position.
- The "Auto" position causes the pump to operate based on the wet well water level in conjunction with the pump control logic.

P. High visibility panel lamps to indicate alarm and status information. The following table contains the indicator and its color.

Indicator Function	Color
Panel Power Indicator	Green
Pump "n" Active	Green
Pump "n" Fault	Red

Q. A pump run-time meter for each pump.

- The pump control panel shall make the following status information available to the SCADA system by way of relay contacts:

Parameter	Relay Contacts	
	Open	Closed
Pump Run Status (for each pump)	Not Running	Running

Pump Failure (for each pump)	Normal	Failure
Wet well level high	Normal	High

Note that this table also contains the contact state associated with the associated status information.

The relay contacts shall be rated for 120VAC operation with a minimum current capacity of 0.1A (100mA).

- The Panel Vendor shall provide training and documentation on the operation, troubleshooting, and maintenance of the control panel. Documentation shall include:

R. Operator's manual(s) which contains the following information:

S. The function of each control and indicator.

T. A troubleshooting guide geared for the operator.

U. Description of fuses and circuit breakers and their locations within the panel.

- Recommended sparing list for field replaceable parts (if any).

V. A copy of the signed-off factory acceptance test procedure.

W. A set of electrical schematics which accurately reflect the actual construction of the control panel. All components and wiring in the control panel shall be uniquely labeled and referenced on the schematics by the appropriate labels. The schematic shall contain a legend table which explicitly describes any acronyms, abbreviations, or non-standard symbols used to describe the circuitry or its components. The schematics shall be laminated and attached to the inside doorway of the panel.

- The panel vendor shall provide an acceptance test procedure and sign-off sheet for use during field acceptance testing. The vendor or an authorized representative shall be required to demonstrate that each function listed in the acceptance test procedure operates properly before the equipment will be accepted.

5.5.3 Control Equipment

The control for each pump shall include a thermal-magnetic circuit breaker, rotary hand-off-automatic switch, and magnetic motor starter with ambient-compensated overload relays and quick-trip heaters. The pump control circuit shall include a door interlock switch to de-energize the control circuit when the enclosure door is opened, a control circuit transformer with fused 115V secondary, and a door-mounted control circuit disconnect switch.

Pump operation shall be controlled by solid-state level sensors which do not rely on float devices.

The controls shall provide for lead/lag sequencing of the pumps, which shall operate singly or in parallel. An automatic alternator shall alternate the lead-lag duty on each

succeeding pump cycle.

An additional level sensor shall be furnished to provide for high-water alarm, which shall be indicated by a switchable top-mounted flashing red light and an external audible alarm with silence button.

5.5.4 Level Sensor/Controllers

A conductance actuated MultiTrobe with back-up conventional tilt switch control system shall be provided. The system shall utilize an indicating controller with necessary intrinsic barriers to both operate both sets of pumps at designated levels and actuate alarms as required.

Probe shall be installed at the locations and elevations shown on the plans. Provide probe cable of adequate length to reach the pump control panel without splicing.

One extra probe shall be with specified cable length as a spare.

5.5.5 Pump Portable Hoist

Each station shall be provided and installed with a hoist system of stainless steel construction specifically sized and designed for the pumps. The portable hoist shall be guaranteed against defects in material and or workmanship for a period of 3 years.

5.6 Additional Information

Contractor shall furnish manufacturer's specifications and shop drawings for RCWD approval prior to installation of any equipment. Shop drawings shall be submitted for pump systems, controls, enclosure, and pit covers.

Pit covers shall be fitted with an aluminum frame and access door capable of supporting AASHTO H-20 loading, and of adequate size to accommodate the pump specified. Doors shall be aligned with pumps and the opening(s) shall sufficiently pass pumps. Doors shall be provided with air cylinder or spring-based lift assist mechanism.

Provide underground electrical service to the lift station and telephone service to the lift station.

Alarms shall be provided for the following conditions: High water, pump failure-to-start, power failure.

5.7 Stand-by Power

Where required by RCWD Engineer, stand-by generators shall be provided at lift stations. Such generators shall be driven by propane-powered, natural gas powered or diesel powered internal - combustion engines. The proponent of the lift station shall be required to obtain a permit from the San Joaquin Valley Unified Air Pollution Control RCWD on behalf of RCWD. Engines shall be sized to supply pump starting in-rush current with a 25-percent safety factor.

When located within residential zones, pumps shall be equipped with "Extra-Quiet" sound enclosures providing reduction of sound pressure levels to 75 dbA or below at a 50-foot

radius from the generator. To the greatest extent possible, generator unit shall be oriented to direct the highest sound levels away from the nearest buildings.

Fuel tanks shall be located so as to provide accessibility for filling from a public right-of-way or access easement, and shall not require pulling fill hose around the genset to reach the tank fill valve. Fuel tank capacity shall be adequate to provide 48 hours continuous loaded operation, or such greater capacity as may be directed by RCWD Engineer.

Owner shall apply for and obtain both construction and operational permits for the generator from the San Joaquin Valley Unified Air Pollution Control District, and shall pay all related fees.

6 STANDARD SPECIFICATION FOR PVC WATER PIPE

6.1 Materials and Assembly

Unless otherwise shown on the Plans, all PVC pressure pipe shall be Class 150, and shall conform to the requirements of ASTM C-900 "Polyvinyl Chloride (PVC) Pressure Pipe" and meet either DR-18 or Dr-14 as shown on standard details W-1 and W-2.

The bell shall consist of a uniform wall section with a solid cross-section elastomeric ring which meets the requirements of ASTM D1869 and E477. The bell shall be designed to be at least as strong as the wall section of the pipe. Provisions shall be made for expansion and contraction at each joint with an elastomeric ring.

6.1.1 Installation

Installation shall conform to Chapter 7, Installation, of AWWA Standard C 605 and AWWA Manual M23.

6.1.2 Tracer Wire

Tracer wire used with PVC where called for on the plans shall be copper wire, Type TW, Size AWG #10 and shall be placed over the PVC water main. Tracer tape is not allowed. All wire to wire connections shall be joined with a wire nut to provide continuity and taped to prevent entry of moisture. Where tracer wire is called for, it shall be securely attached to each fire hydrant and each main line valve casing.

6.1.3 Joint Checking

After assembly of each joint, the elastomeric ring shall be checked with a suitable gauge. If the location of the ring is not within acceptable limits, the joints shall be disassembled and reassembled in an acceptable manner.

6.2 Fittings

The fittings for PVC pipe shall be cast iron as specified under ASA standard specification A21.10 (AWWA C110) with the wall thickness conforming to AWWA Specification C100. All fittings shall have hub ends with two (2) rubber ring seals, designed for use on PVC pipe without special milling. The fittings shall be cement mortar lined as specified under ASA A21.4 (AWWA C104).

6.3 Alignment

Pipes will be point to point with straight lines. No bending or pulling of joints is allowed. The pipe shall be wholly under the road section.

7 STANDARD SPECIFICATIONS FOR BLOW-OFF ASSEMBLIES

7.1 General

Blow offs shall be installed by the Contractor at low points and dead ends, where sediment may collect, and at the locations shown on the Plans. Design class shall be compatible with pipeline working pressure. The Contractor shall furnish all labor, materials, tools and equipment necessary to furnish and install, complete and ready for operation, the assemblies as shown on the Plans and herein specified. See Standard Drawing W-18.

7.2 Materials, Fabrication and Installation

7.2.1 Materials

Materials shall be of the size and kind designated on the Standard Drawings and/or Plans.

7.2.2 Earthwork

Earthwork shall be in accordance with the *Standard Specifications for Earthwork (Pipelines)*.

8 STANDARD SPECIFICATIONS FOR WATER SERVICE ASSEMBLIES TWO INCHES AND SMALLER

8.1 General

Water service assemblies shall be furnished and installed by the Contractor at the locations shown on the Plans or established in the field by the District's Representative. The Contractor shall furnish all labor, materials, tools and equipment necessary to furnish and install, complete and ready for operation, the assemblies as shown on the Plans and herein specified:

8.2 Materials, Fabrication, and Installation

8.2.1 Materials

Materials shall be those designated on the Standard Drawings or Plans. See Standard Drawings W-12, W-13, and W-14.

8.2.2 Pipe and Fittings

Service pipe shall conform to the *Standard Specification for Water Service Tubing*. Copper and brass fittings shall be as designated on the Standard Drawings. Each item shall be new and conform to ASTM B62.

Meter Size	Corp. Stop	Copper Tubing	Polyethylene Tubing	Angle Valve
1"	1"	1"	1"	1" x 1"
1½"	1½"	1½"	1"	1½" x 1½"
2"	2"	2"	2"	2" x 2"

8.2.3 Meters

Meters will be supplied by RCWD at the Contractor's expense. Two-inch meters shall have flanged connections.

8.2.4 Service Taps

In no case shall a service tap be made in a main closer than 18 inches to a bell coupling joint, or fitting. Service taps shall not be less than two (2) feet apart. Service taps shall be located opposite the meter locations so that the service laterals will be perpendicular to the water main and street centerline. Service tap locations varying more than five (5) feet from the perpendicular must be approved by the District's Representative prior to installation. Unless otherwise noted on the plans, service taps shall be located so that the water service lateral is parallel to and 2 feet from the property line.

To the greatest extent practical, water services shall be grouped so that services for adjacent properties are four (4) feet apart (two feet each way from the common property line)

8.2.5 Dielectric Connections

Dielectric Connections shall be provided where dissimilar metals are joined and shall conform to the Standard Drawings.

8.2.6 Meter Boxes

Meter boxes and covers shall be Old Castle, or approved equal as follows:

Meter Size	Meter Box Model
1"	FL12T
1 ½"	FL30T
2"	FL36T

Meter boxes shall be set with longitudinal axis perpendicular to the street and set back from the face of curb as shown on Standard Drawing W-12, 13 and 14. Where concrete curbs are not existing or are not to be constructed as part of the improvement plans, meter boxes shall be set 12 inches inside the public street or RCWD right-of-way. Meter boxes shall not be set in driveways. Meter boxes at locations subject to automotive traffic loads must be approved by the District's Representative prior to installation and shall be traffic-rated concrete boxes furnished with RCWD-approved cast iron covers.

8.2.7 Spacers

Spacers consisting of 1-1/4" galvanized iron pipe (for 1" x 1" meters) shall be set in place of RCWD installed meter. Care must be taken to avoid placing a strain on the spacer through misalignment of the house or service pipe. RCWD will not accept sealed services that do not readily accommodate RCWD inserted equipment.

8.2.8 Earthwork

Earthwork shall conform to the *Standard Specifications for Earthwork (Pipelines)*.

9 STANDARD SPECIFICATIONS FOR GATE VALVE ASSEMBLIES

9.1 General

Gate valve assemblies shall be furnished and installed by the Contractor at the locations shown and/or established in the field by the District's Representative. The Contractor shall furnish all labor, materials, tools and equipment necessary to furnish and install, complete and ready for operation, the valves as shown on the Plans and herein specified.

9.2 Materials, Fabrication and Installation

9.2.1 Gate Valves

Gate valves shall meet the requirements of AWWA specifications C-509 and, unless otherwise indicated, shall be the same size as the main or service in which they are installed. Valves shall be rated by the manufacturer for the working pressure of the pipeline in which they are installed. All gate valves shall be counter-clockwise opening. Buried gate valves shall be equipped with 2-inch square cast iron operating nuts. Exposed gate valves shall have hand wheels.

9.2.2 Gate Valves, 3-Inch and Smaller, Not Buried

The body and all interior working parts, except stems, shall be constructed of ASTM B62 (85-5-5-5) or ASTM B61 bronze. Gate valves shall be rising stem union bonnet, and shall have a double disc, except that a wedge disc will be accepted for Class 300 service and for 1-inch and smaller sizes. The stem bronze shall not contain more than two percent (2%) aluminum nor more than seven percent (7%) zinc and shall meet these additional requirements: a minimum tensile strength of 60,000 psi, a minimum yield strength of 30,000 psi, and a minimum of ten percent (10%) elongation in 2-inches.

9.2.3 Gate Valves, 4-Inch Through 12 Inches

Gate valves shall be non-rising stem, iron body, solid bronze internal working parts, with a styrene-butadiene rubber seat permanently bonded to an iron wedge. Bonding process shall meet ASTM D429 requirements. The minimum designated water working pressure shall be 200 psi.

Valves designated for PVC pipe shall be mechanical joint and shall have bell dimensions which conform to ASA A21.11 (AWWA C111).

9.2.4 Interior Coating

The interior of valve bodies except the bronze and working parts shall be coated with 100 percent solids, catalytically setting epoxy which is manufactured for use in the interior of potable water systems. The fusion method of coating 100 percent solid epoxy is acceptable. The two components shall be of different colors to aid in complete mixing. A two-coat application shall be made over the manufacturer's recommended primer. Sandblast cleaning to white metal in accordance with SSPC Specification No. 5 shall precede painting. All protuberances that may produce pinholes shall be removed, sharp edges shall be rounded, and special care shall be taken to remove contaminants which may prevent a bond adjacent to seating rings. The manufacturer's pot life and maximum and minimum curing times shall be observed. Minimum total coating thickness shall be 18 mils.

9.2.5 Exterior Coating

As directed by RCWD during the Plan approval process, valve bodies, except bronze, and operator housings and extensions shall receive two exterior coats of heavy duty coal tar equal to Koppers' Bitumastic No. 505. Minimum thickness is 15 mils per coat. Application shall be at the place of manufacture.

In addition to the bitumastic coating, a 10-mil wrap of polyethylene film shall completely encapsulate the valve, flanges and nuts and bolts on the flange

9.2.6 Valve Boxes

Valve Boxes shall conform to the Standard Drawings. Steel pipe shall be coated with the best grade of air-blown California asphalt pipe dip. Valve box covers shall be as per the Standard Drawings. Covers shall be seated 2-inches above the surface of the natural ground and flush with paved surfaces. Covers shall have a concrete ring constructed as shown on the Standard Drawings.

9.2.7 Nuts and Bolts

Nuts and Bolts used for bolting flanged-end gate valves to pipeline flanges above ground shall be a standard hex head machine bolts and hexagonal nuts conforming to ASTM A307, Grade "B". All buried flanged-end gate valves shall be bolted to the pipeline flanges with stainless steel nuts and bolts, Type 304, except that all nuts and bolts 1-1/8-inch and larger in diameter shall be cadmium plated. All bolt threads shall be lubricated with graphite and oil.

9.2.8 Gaskets

Gaskets for flanged-end gate valves shall be full face 1/16-inch "Cranite" with bolt holes pre-punched, or RCWD approved equivalent.

9.2.9 Marker Posts

In all easements and where called for on the Plans, gate valve assemblies shall be marked with a marker post to be located as directed by the District's Representative. Posts shall be dense structural grade redwood 4"x4"x5'-4", surfaced on four (4) sides with top chamfered. The posts shall be painted with two coats of white enamel. On the side facing the water main or roadway, the legend *RCWD* and the distance in feet from the post to the valve shall be stenciled in black letters 2-inches high. Posts shall be set 2'-4" into the ground.

10 STANDARD SPECIFICATION FOR WATER SERVICE TUBING

10.1 Copper Tubing

10.1.1 General

All copper Tubing shall be new, and shall conform to ASTM Specification B88, Type ``K”.

10.1.2 Grade and Type

Tubing is to be furnished in annealed 64-foot coils. The tubes shall be clean, smooth, round, of proper dimensions, free from grooving, indentations, cracks, flaws and scale. Copper shall have a purity of at least 99.99 percent as determined by electrolytic assay, except that silver may be counted as copper.

10.1.3 Coating

Copper tubing will be wrapped with a minimum 6 mil polysleeve encasement, meeting ASTM D-1248.

10.1.4 Marking

The name or trademark of the manufacturer and a symbol indicative of the type shall be permanently marked on the tubing at intervals not greater than 1-1/2 feet.

10.1.5 Testing of Copper Tubing

RCWD will make tests, conforming to ASTM B88, locally as it considers necessary. Such tests will be a basis for acceptance or rejection under this section. Should random sampling disclose unsatisfactory tubing, the entire lot may be rejected. All rejected material shall be handled at the expense of the Contractor.

10.2 Polyethylene (PE) Tubing

10.2.1 Grade, Type, and Size

All polyethylene tubing shall conform to the requirements of Type III, Grade 3, and Class C, as described in ASTM D2239. All PE tubing shall be in copper tubing sizes.

10.3 Installation and Fittings

All corporation and curb stops shall be compression-type. All curb stops must be exposed for final inspection. Any damaged or improperly located services will be rejected by the District's Representative, and shall be repaired by the Contractor. Each item shall be new and shall conform to ASTM B62.

11 STANDARD SPECIFICATIONS FOR FIRE HYDRANT ASSEMBLIES

11.1 General

Fire Hydrant assemblies shall be furnished and installed by the Contractor at the locations shown and/or established in the field by the District's Representative. The Contractor shall furnish all labor, materials, tools, and equipment necessary to furnish and install, complete and ready for operation, the assemblies as shown on the Plans and herein specified.

11.2 Materials, Fabrication and Installation

11.2.1 Materials

Materials shall be those designated on the Standard Drawings.

11.2.2 Fire Hydrant Heads

Fire Hydrant Heads, 6-inch, shall be all bronze, with 6-inch flanged inlet, two 2-1/2-inch and one 4-1/2-inch valve outlets. National Standard fire hose threads covered with cast iron caps attached with chains to the fire hydrant head shall be used.

11.2.3 Hydrant Riser Spools

Hydrant Riser Spools shall be cast iron spools 6-inches in diameter. The riser shall be cement mortar lined and seal coated in accordance with the latest revisions of ANSI Specifications A21.4 (AWWA C104). The exterior surface shall be painted with two coats of Sherwin Williams Georgia Bay SW6509 High Gloss exterior enamel. Where there is no curb, the elevation of the top of the riser shall be equal to the center of street elevation or as determined by the District's Representative.

11.2.4 Hydrant Bury

Hydrant buries and spools shall be 6-inch inside diameter cast iron. The interior surfaces shall be cement mortar lined and seal-coated in accordance with ANSI Specification A21.4 (AWWA C104). The exterior surface shall be coated with two coats of Koppers' Bitumastic #505, or equivalent. It shall be applied per the manufacturer's instructions to a minimum thickness of 15 mils each coat. In addition to the bitumastic coating, all underground flanges shall be encapsulated in a 10-mil wrap of polyethylene film.

11.2.5 Gate Valves

Gate Valves shall conform to the applicable provision of the *Standard Specifications for Gate Valves* and shall be bolted to the water main tee or flanged outlet.

11.2.6 Nuts and Bolts

Nuts and Bolts shall conform to the applicable provision of the *Standard Specifications for Gate Valves*.

11.2.7 Earthwork

Earthwork shall conform to the provisions of the *Standard Specifications for Earthwork (Pipelines)*.

11.2.8 Guard Posts

Guard Posts are required except where hydrant is located behind a concrete curb. See Standard Drawing W-29.

12 STANDARD SPECIFICATIONS FOR MANUAL AIR RELEASE ASSEMBLIES

12.1 General

Manual air release assemblies shall be furnished and installed by the Contractor at the respective locations shown and/or established in the field by the District's Representative.

12.1.1 Scope of Work

The work shall include the fabrication and installation of the complete assemblies including water main taps, service clamps, corporation stops, copper tubing and fittings, valves, meter boxes or pipe sleeves and covers, and marker posts, as indicated on the Plans and Standard Drawings.

12.2 Materials, Fabrication and Installation

12.2.1 Materials

Materials shall be those designated on the Plans or approved equals.

12.2.2 Pipe and Fittings

Copper tubing shall be Type "K," soft. All copper tubing connections shall be made with 95% tin /5% lead solder or silver solder (pure).

12.2.3 Pipe Sleeves and Covers

The steel pipe sleeves shall be coated inside and out with the best grade of air-blown California asphalt pipe dip. Covers shall be seated flush with the surface of the natural ground or paved surface such that they may not be damaged by or present an obstruction or rough surface to traffic. Covers set in existing surfacing or public rights of way shall have a concrete ring constructed as shown on the Standard Drawings. In curbed streets a meter box with cover, as shown on the Standard Drawings, shall be used in lieu of the steel pipe sleeve and cover.

12.2.4 Marker Posts

In all easements and where called for on the Plans in streets, blow-offs shall be marked with a marker post. Timber for marker posts shall be dense structural grade redwood, graded according to the current standards of the California Redwood Association. Posts shall be 4" x 4" x 5'-4," surfaced on four (4) sides and chamfered. The posts shall be painted with two coats of white enamel. On the side facing the water main or roadway, the legend RCWD and the distance in feet from the post to the gate valve shall be stenciled in black letters two (2) inches high. Posts shall be set 2'-4" into the ground.

12.2.5 Earthwork

Earthwork shall be done in accordance with the Standard Specifications for Earthwork (Pipelines).

13 STANDARD SPECIFICATIONS FOR TESTING AND STERILIZATION

13.1 General

These Specifications designate the requirements for field testing and sterilization of all water mains intended for the conveyance of potable water under pressure. The Contractor shall furnish all labor, materials (including water), tools, and equipment necessary to provide and complete field testing and disinfection, as specified.

13.2 Acceptance Tests And Inspection For Pressurized Water Piping

- 13.2.1 All testing and inspection shall be performed after final backfill and compaction operations are complete. If the Contractor so desires, he may pretest the lines at his own expense, but final testing must be performed after compaction requirements have been approved.
- 13.2.2 If any of the tests or inspections covered in this section indicates that pipe requires repair, then after repairs are complete, all testing and inspection shall be performed again, at the Contractor's expense.
- 13.2.3 Prior to testing, all lines shall be thoroughly cleaned by flushing. Contractor shall protect the existing water system from contaminants during the flushing operation.
- 13.2.4 Cost of all testing shall be included as a part of Contractors work.
- 13.2.5 In general, tests shall be conducted in accordance with AWWA C600 and C651 except as otherwise herein specified.
- 13.2.6 All newly installed sections of buried pressure piping shall be pressure and leakage tested as described herein.
- 13.2.7 For buried pressure pipelines, tests shall be made on two or more valved sections not to exceed 2,500 feet in length. The Contractor shall furnish all necessary equipment, material, and labor required.
- 13.2.8 Tests shall be made after the trench has been backfilled and compacted.
- 13.2.9 The pipe shall be filled with water and all air expelled from section being tested. A test pressure equal to 1.5 times the design pressure, of the pipe measured at the point of lowest elevation pressure, or 150 psi, whichever is greater, shall be applied.
- 13.2.10 The test pressure in the line shall be maintained for a period of 4 hours. Test pressure shall be maintained within 5 psi during the test period by adding water as required. The water required to maintain test pressure shall be measured by means of a graduated barrel, drum, or similar device at the pump suction or through a meter.

13.3 Field Testing

13.3.1 Procedure

After the pipe and all appurtenances have been laid and sufficiently backfilled for required restraint, they shall be subjected to a 4-hour hydrostatic pressure test. This test shall

consist of applying to the pipeline a pressure of 150 psi. Pressure tests or a retest shall be conducted subsequent to any trench backfill compactive effort with heavy duty compacting equipment having an overall weight in excess of 100 pounds.

13.3.2 Maximum Length of Pipe

Maximum length of pipe to be included in any one test shall be no more than 2,500 feet or the distance between valves, whichever is greater. The Contractor shall provide suitable test bulkheads, blocking, and fittings to permit such sectionalizing.

13.3.3 Preparation

The test shall be applied at an approved outlet or fitting located within an elevation of five (5) feet of the lowest point of the pipe section to be tested. The Contractor shall provide and later securely plug such fittings. While filling and immediately prior to testing, all air shall be expelled from the pipeline. Where air valves or other suitable outlets are not available, approved taps and fittings shall be provided at all high points and later securely plugged.

13.3.4 Procedure

The pressure in the pipeline shall be raised to the specified test pressure. When the test pressure has been reached, the pumping shall be discontinued until the pressure in the line has dropped 10 psi, at which time the pressure shall again be raised to the specified test pressure. This procedure shall be repeated until 4 hours have elapsed from the time the specified test pressure was first applied. At the end of this period, the pressure shall be pumped up to the test pressure for the last time.

13.3.5 Leakage

Leakage shall be considered as the total amount of water pumped into the pipeline during the two-hour period, including the amount required in reaching the test pressure for the final time.

Allowable leakage at the specified test pressure shall not exceed the
amounts allowed by AWWA C600, $L = \frac{SDP}{148,000}$

Where:

L = Testing allowance in gallon per hour.

S = Length of pipe tested in feet.

D = Nominal diameter of the pipe in inches.

P = Average test pressure during the hydrostatic test, in pounds per sq. inch.

Hydrostatic testing allowance per 1,000 ft. of pipeline in GPH.

PSI	4"	6"	8"	10"	12"	14"	16"	18"	20"	24"
150	0.33	0.55	0.66	0.83	0.99	1.16	1.32	1.49	1.66	1.99

13.3.6 Should testing disclose any visible leaks or leakage greater than that allowed, the defective joints or pipe shall be located, repaired, and re-tested until satisfactory. The cost of any retests, including time for the District, shall be borne by the Contractor at no additional cost to the project.

Allowable leakages for other lengths of pipe shall be prorated from the above. Combinations of pipe of different sizes shall be calculated on a pro rata basis.

13.3.7 Acceptance Test For Exposed Piping

13.3.7-1 Pipe to be Tested - All newly installed piping sections shall be pressure and leakage tested as specified herein.

13.3.7-2 Pressure Testing - After the section of line to be tested has been filled with water or other test media, the test pressure shall be applied and maintained without interruption for 4 hours plus any additional time required for the District to examine all piping undergoing the test and for the Contractor to locate all defective joints and materials.

- Test medium shall be potable water for potable water piping; all other piping may be tested using plant water subject to District's approval.
- Pipe system shall be tested at 1-1/2 times the operating pressure, or 150 psi, whichever is greater, using the appropriate test fluid medium for a period of 4 hours.
- All piping shall be tight and free from leaks. All pipe, fittings, valves, pipe joints, and other materials that are found to be defective shall be removed and repaired or replaced with new and acceptable material, and the affected portion of the piping be retested until satisfactory. The cost of any retests, including time for the District, shall be borne by the Contractor at no additional cost to the project.

13.3.8 Compressed air or gas under pressure shall not be used to test plastic piping unless specifically recommended by the pipe manufacturer.

Leakage may be determined by loss of pressure, soap solution, chemical indicator, or other positive and accurate method acceptable to the District. All fixtures, devices, or other accessories which are to be connected to the lines and which would be damaged if subjected to the specified test pressure shall be disconnected and ends of the branch lines plugged or capped as required during the testing procedures.

13.4 Disinfection

13.4.1 Disinfection Of Pressurized Potable Water Piping

13.4.2 General

- After pressure testing and prior to acceptance of the work, the entire pipeline, including all valves, fittings, hydrants, service laterals, and other accessories, shall be disinfected.
- All disinfection shall be conducted in accordance with AWWA C651 – Disinfecting Water Mains, except as modified herein.
- All disinfection shall be performed after final backfill and compaction operations are complete.
- The length of water main that can be flushed at one time shall be limited to 2,500 feet during high-demand seasons (May 15 through September 15). Outside of the high-demand seasons, the length of main flushed shall be such that flushing and disinfection is consistent with AWWA C651 and pipe manufacturer recommendations.
- If any of the other tests or inspections indicates that pipe requires repair, then after repairs are complete, all disinfection shall be performed again, at the Contractor's expense.
- Cost of all testing shall be included as a part of Contractors work except for monitoring, sampling, and bacteria laboratory testing as noted below.

13.4.3 Disinfection - Prior to acceptance of work, the entire pipeline including all valves, fitting, hydrants, service laterals, and other accessories shall be sterilized in accordance with AWWA C651 latest revision.

- All mains shall be flushed with potable water after completion of construction and prior to disinfection. The Contractor shall provide a sufficient number of suitable outlets at the end(s) of the line(s) being sterilized in addition to those required by the plans, to permit the main to be flushed with water at a velocity of at least 5.5 feet per second over its entire length. The outlets provided shall meet the requirements for fittings as specified for the type main constructed. Temporary blow-offs shall be installed during the sterilization and flushing to satisfy these requirements.
- Drainage facilities shall be constructed such that the water lines cannot be contaminated through the flushing outlet.
- Continuous-Feed method of chlorination using liquid sodium hypochlorite shall be the only acceptable method of disinfection unless otherwise approved by the District

Engineer.

- Contractor is required to be on the site during the entire sterilization period.
- During the sterilization process all valves, hydrants and other accessories shall be operated.
- After final flushing, the flushing fitting shall be plugged with devices intended for this purpose at the pressure class of the pipe. Where water main is coated, plugs and outlets shall be similarly coated.
- Initial laboratory costs will be paid by the District and the cost of all related work, sampling, and laboratory retesting shall be billed to the Contracting entity at a fixed rate of \$200 per test.
- The Contractor shall direct all flushing water to the extent possible to the storm drainage system. The metered outlet of the storm drainage basin shall be dechlorinated using sodium ascorbate per AWWA C655 prior to discharge.
- In the event of unauthorized chlorinated water discharges, Contracting entity shall be held solely liable for actual sustained farming and related losses including but not limited to the removal and replacement orchard stock, estimated crops, and all other incidental consequential losses.
- The District will be engaged throughout this process and will conduct water quality monitoring, water quality sampling, water quality field testing, coordinate laboratory testing, pay laboratory costs, and provide written laboratory test results.

13.4.4 Bacteriologic Samples

Bacteriological tests shall be conducted in accordance with AWWA C651. Method A will be the method used for testing. Method B can be used if requested and approved by the District Engineer.

13.4.5 Quality Assurance Bacteriologic Samples

At water mains that fail initial specified bacteriological tests and then are corrected and pass specified bacteriological requirements, a second round of bacteriological samples shall be taken no sooner than 24 hours or longer than 48 hours after the first round of passing bacteriological tests. The second round of bacteriological tests must pass before the water main may be placed into service. Costs of related work and sampling shall be paid by Contractor as noted above at Section 13.4.4.

13.4.6 Disinfection and Sampling Plan

All water main disinfection and bacteriological testing shall be shown on a Disinfection and Sampling Plan and submitted to the District for review a minimum of five working days prior to disinfection and bacteriological testing. The Disinfection and Sampling Plan shall consist of a plan sheet identifying:

- Water utilities only, including but not limited to water mains, valves, sampling stations, fire hydrants, blowoffs, air release valves, and backflow prevention devices.
- Locations of disinfectant injection
- Locations of sampling points
- Mains that will be isolated for disinfection and how this will be achieved (which valves will be closed)

After disinfection and sampling, the test results shall be shown on the plan at each sampling location, including but not limited to:

- Initial chlorine concentration (after refilling main with water chlorinated to 25 mg/L, up to 100 mg/L)
- Final chlorine residual (after 24-hr holding period, meeting minimum of 10 mg/L, or half of the initial concentration)
- Bacteriological test results of two sample sets taken per AWWA C651 Section 5.1.1.1.

Disinfection and testing shall be coordinated with the District. A proposed date and time for disinfection and testing will be provided to the District 48 hours prior to commencing work. The District will respond within 24 hours to confirm the time or may propose an alternative time that does not conflict.

14 POLYPROPYLENE (PP) PLASTIC PIPE

14.1 General

This work shall consist of furnishing all labor, materials, tools and equipment, testing, and all incidentals necessary to furnish and install Polypropylene (PP) Plastic Pipe where the use of such pipe is shown on the Plans or specified in the Special Provisions and approved by the District as a permitted substitution for RCP as provided in Section 15.2.1, "Pipe Substitutions". Unless shown on the Plans or specified in the Special Provisions as permitted use, PP Plastic Pipe will not be permitted. In all cases, approval for use of PP Plastic Pipe shall be obtained from the District prior to award of the Contract. Where installation is permitted, all work and materials shall be in accordance with these Specifications and as directed by the District Engineer.

PP Pipe shall be no greater or smaller than eighteen (18) inches in diameter unless specifically approved by the District Engineer in writing. Maximum cover exceeding 16 feet must be reviewed and approved on a case-by-case basis by the District.

14.2 Materials

PP Pipe, fittings, and joints shall conform to the following specifications. The Contractor shall furnish certificates of compliance as directed by the District Engineer.

The residue from the ignition of polypropylene compounds must not exceed 30 percent as determined under ASTM D2584 except the muffle furnace temperature must be 840 ± 45 degrees F.

Pipes and fittings must be homogenous throughout and uniform in color, opacity, density, and other properties. The inside and outside surfaces must be semimatte or glossy in appearance and free of chalky, sticky, or tacky material. The pipe walls must be free of cracks, holes, blisters, voids, foreign inclusions, or other defects affecting the pipe wall integrity or visible to the naked eye. Do not use pipes or fittings with abrasions or scratches deeper than 10 percent of the wall thickness. The joint surfaces where the gaskets bear must be smooth and free of imperfections, ridges, fractures, or cracks that could adversely affect the joint seal. Store pipes in unit packages and protect the bell end of the pipes from damage. Support unit packages with racks or dunnage to prevent damage and bending. If unit packages are stacked, do not allow the weight of the upper units to cause deformation to the pipes in the lower units. Do not store pipes adjacent to heat sources. Do not allow pipes to overhang vehicles or storage areas unsupported by more than 3 feet.

Cover pipes to provide temporary sun block protection. Provide adequate air circulation around the covered pipes to reduce excessive heat accumulation. Protect gaskets from exposure to weather, heat, ozone, oil, grease, and sunlight for any time period exceeding 48 hours. Do not store gaskets near electrical or exhaust heat sources.

The District rejects pipes with cracked or split gaskets.

Protect pipes and fittings from damage when handling and installing.

14.2.1 Pipe and Fittings

PP Plastic Pipe and fittings shall be high-performance polypropylene with annular exterior corrugations, smooth interior wall, conforming to AASHTO M330 or ASTM F 2881, and

the applicable provisions of Section 64-2, "Plastic Pipe" of the Caltrans Standard Specifications. Pipe shall be suitable for storm drain applications. Fittings shall be fabricated by the pipe manufacturer.

14.2.2 Joints

Joints for pipe and fittings shall be bell and spigot type using flexible elastomeric seals (rubber gaskets), all conforming to ASTM Designation: D 3212, "Standard Specifications for Joints for Drain and Sewer Plastic Pipes using Flexible Elastomeric Seals". Joints shall be watertight and shall meet the 10.8 psi (25-foot head) internal pressure test according to the requirements of said ASTM D 3212. Elastomeric seals shall conform to ASTM Designation: F 477. Elastomeric seals shall be installed by the manufacturer and covered with a removable wrap to ensure the gasket is free from debris. Pipes furnished without removable wraps covering the gaskets may be rejected by the District Engineer for use in the Work. Only joint lubricant furnished by the pipe manufacturer shall be used on the seals and bell during assembly. The Contractor shall upon request furnish the District Engineer with certification that the lubricant being used was furnished by the pipe manufacturer. The ends of PP Plastic Pipe shall be of such design that when properly joined, they shall have a smooth and uniform interior surface across the face of the joint.

14.3 Installation

PP Plastic Pipe shall be installed in compliance with the manufacturer's specifications and in compliance with ASTM Designation: D 2321, "Standard Practice for Underground Installation of Thermoplastic Pipe for Sewers and Other Gravity-Flow Applications", except as modified in this Section 14.3.

14.3.1 Excavation

Excavation for installing PP Plastic Pipe shall comply with the requirements of Section 2.4.2, "Trench and Structure Excavation", and ASTM Designation: D2321, except that the following minimum trench width shall apply:

<u>Pipe Internal Diameter</u>	<u>Minimum Trench Width</u>
18"	OD + 21"

OD = Outside Diameter of Pipe

These widths are to provide space to conduct appropriate backfill compaction under and around the pipe haunches. While they are "minimum", the Contractor shall make every attempt not to excavate trenches any wider than necessary. The Contractor may, with the approval of the District Engineer, reduce the above trench widths by use of a slurry cement or other approved initial backfill material. Reference is made to Section 14.3.6, "Slurry Cement Haunching and Initial Backfill".

Pursuant to said Section 2.4.7, trenches encountering rock, hardpan, or other material in the trench bottom unsuitable for pipe bedding, as determined by the District Engineer, shall be overexcavated four (4) inches and backfilled with bedding material complying with Section 14.3.2, "Bedding". Where wet, spongy, or other unstable material is encountered, trenches shall be over-excavated twelve (12) inches, or to such other depth as determined by the District Engineer to remove unsuitable material, and backfilled with bedding as provided in said Section 14.3.2. The cost of over-excavating and providing

bedding for trenches shall be considered as included in the price paid for PP Plastic Pipe, and no additional payment will be made therefor.

14.3.2 Bedding

Bedding shall be furnished for PP Plastic Pipe conforming to Standard Detail D-18 and material requirements in Section 14.3.10. The cost for providing bedding shall be considered as included in the price paid for PP Plastic Pipe, and no additional payment will be made therefor. Reference is made to Section 14.3.6, "Slurry Cement Haunching and Initial Backfill".

14.3.3 Pipe Laying

Pipes shall be laid in conformity with the prescribed lines and grades obtained from survey stakes set by the District Engineer. The pipe shall be laid uphill from structure to structure with the bell end up-grade. During jointing operations, the two sections to be joined shall be firmly placed together in such a manner that the bell or groove end of the pipe fits truly and snugly over the tongue end. The tongue end shall be inserted into the bell end up to the manufacturer's index mark, if so provided on the pipe. Adjustments of pipes to line and grade shall be made under the body of the pipe throughout its entire length and not by blocking or wedging. Bell holes shall be accurately placed and shall not be larger than is reasonably required to make the joint. Before the pipe is laid, the interior of the bell of the preceding pipe shall be carefully cleaned. Reference is made to Section 14.2.2, "Joints". Lubrication shall be applied to the joint in accordance with the manufacturer's recommendations. There shall be no appreciable gap between the ends of pipes at joints, except as permitted by Section 14.4, "Curved Alignments". After jointing procedures have commenced, there shall be no movement of the pipe whatsoever in subsequent operations. Material shall be placed uniformly on either side of the pipe to prevent any movement, in accordance with Section 14.3.5, "Haunching, Initial Backfill and Compaction".

14.3.3-1 Floatation Prevention

The Contractor shall take appropriate measures to prevent floatation of the pipe during all backfill operations, including placement of backfill per Section 14.3.5, "Haunching, Initial Backfill and Compaction", and Section 14.3.6, "Slurry Cement Haunching and Initial Backfill". The entire length of the pipe shall be anchored by methods approved by the District Engineer to prevent any vertical or horizontal movement of the pipe during such operations. Anchors shall cause no deflections in or damage to the pipe, and shall be removed once the pipe is sufficiently stable in position after sufficient backfill has been placed. The Contractor shall provide pipe grade control during installation and make any adjustments in pipe position to conform to lines and grades shown on the Plans before placement of final backfill. Performance of Floatation Prevention shall in no way relieve the Contractor of the responsibility to excavate and re-lay pipeline found by tests as provided in Section 14.6, "Testing", to be out of conformance with the lines and grades shown on the Plans. The cost for providing Floatation Prevention shall be included in the price bid for PP Polypropylene Plastic Pipe, and no additional payment will be made therefor.

14.3.4 Construction Joints

Reference is made to the Standard Detail D-3. Whenever two sections of pipe are to be connected where standard joints are not available, such as joining reinforced concrete pipe to cast-in-place concrete pipe or plastic pipe, or in cases where field conditions are encountered which require a pipe joint to be deflected at an angle exceeding the manufacturer's maximum recommended deflection and the Engineer approves the use of a construction joint, an external concrete collar shall be constructed around the full periphery of the pipe and extending one (1) foot on both sides of the joint. The collar shall be of a minimum thickness equal to that of the concrete pipe wall, but in no case less than four (4) inches thick. The interior of the joint shall be smoothed with cement mortar and brushed. The area to receive the collar shall be thoroughly cleaned and dampened immediately prior to construction of the collar.

14.3.5 Haunching, Initial Backfill, and Compaction

Haunching and Initial Backfill shall be placed from the top of bedding to one (1) foot above the outside top of pipe according to Standard Detail D-18. Haunching shall consist of Initial Backfill material placed underneath the pipe haunches up to the springline of the pipe in layers not to exceed six (6) inches in depth, with each layer compacted in conformance with Section 17.4, "Compaction". Each layer shall be thoroughly rammed and hand tamped, being careful to completely compact the material but in such a manner as not to move or lift the pipe from its planned line and grade. The pipe shall be anchored as necessary to prevent movement or lifting. Any pipe that is moved or lifted shall be removed and re-laid to the line and grade shown on the Plans. Initial Backfill shall then be placed above the haunching in layers not to exceed six (6) inches in depth as shown on Standard Detail D-18. Each layer shall be compacted in conformance with Section 2.4. Haunching and Initial Backfill material shall meet the requirements shown in Standard Detail D-18 and Section 14.3.10. Use of Slurry Cement conforming to RCWD Standard Detail D-19 as bedding or backfill shall only be used with the specific approval of the District Engineer or where specified in the Special Provisions. In such cases, the Contractor shall take appropriate measures to anchor the pipe to prevent floating as specified in Section 14.3.3.1, "Floatation Prevention". Any pipe that has floated shall be removed and re-laid at the correct line and grade.

14.3.6 Slurry Cement Haunching and Initial Backfill

Where shown on the Plans or specified in the Special Provisions, or specifically approved for use by the District Engineer, Slurry Cement Backfill to be used in lieu of haunching and initial backfill material as specified in Section 14.3.5, "Initial Backfill, Haunching, and Compaction", or as bedding material required pursuant to Section 14.3.2, "Bedding", shall conform to RCWD Standard Detail D-19.

Slurry Cement Backfill used for haunching and initial backfill shall be placed according to Standard Detail D-19. When slurry cement is used as bedding and/or as initial backfill, in accordance with Section 14.3.3.1 "Floatation Prevention", the Contractor shall take measures approved by the District Engineer to anchor the pipe for its full length to prevent floating. Any pipe that has floated from line or grade shall be removed and re-laid to proper line and grade. Unless otherwise specified in the Special Provisions, no additional payment will be made for Slurry Cement Bedding or Haunching and Initial Backfill.

Backfill may be placed over Slurry Cement Backfill no sooner than four (4) hours after placement of the Slurry Cement Backfill unless concrete sand is used for the aggregate in the slurry cement, the adjacent undisturbed material is free draining, and water is no longer standing on the slurry cement, all as determined by the District Engineer.

14.3.7 Final Backfill and Compaction

Final backfill for the remainder of the trench from one (1) foot above the outside top of pipe to the surface shall be performed in accordance with Section 2.4.19, "Final Backfill". Compaction shall comply with Section 17.4, "Compaction".

14.3.8 Minimum Cover

Unless otherwise shown on the Plans or specified in the Special Provisions, where it is necessary to deviate from the pipe elevations shown on the Plans, as determined by the District Engineer, the pipe shall be placed such that the minimum cover over PP Plastic Pipe shall be three (3) feet, as measured from the lowest finish roadway elevation or ground surface elevation in non-roadway installations, except that within retention basins, minimum cover shall be four (4) feet. Unless otherwise shown on the Plans, specified in the Special Provisions, or approved by the District Engineer, no reduction in minimum cover will be allowed when slurry cement is used for Haunching and Initial backfill.

In cases where the minimum cover over the pipe as above specified may be reduced to less than the specified amounts, the Contractor shall provide and place bedding and backfill as directed by the District Engineer for the conditions encountered

14.3.9 Manhole Connections

PP pipe connections to concrete manholes shall be watertight and flexible. Connections shall be made with using a manufactured resilient rubber boot and pipe adapter gasket system or with a precast compression gasket system and manhole adapter with pipe adapter gasket system compatible with PP and concrete manholes. Connections shall be installed per manufacturer requirements to allow for differential settlement and maintain watertight integrity.

14.3.10 Material for Bedding and Initial Backfill

Material for bedding and initial backfill shall conform to ASTM D 2321, Class II or III material. Unless otherwise specified in the latest edition of ASTM D 2321, Class II and Class III material are defined as follows:

- Class II: clean, coarse-grained soils comprised of any of the following soil groups: SW, SP, GW, GP or any soil beginning with one of these symbols with less than or equal to 12 % passing the #200 sieve.
- Class III: coarse grained soils with fines comprised of any of the following soil types: GM, GC, SM, SC, or any soil beginning with one of these symbols and containing greater than 12 % passing the #200 sieve; sandy or gravelly fine-grained soil comprised of any of the following soil groups: CL, ML, or any soil beginning with one of these symbols with greater than or equal to 30 % retained on #200 sieve.

14.4 Curved Alignments

Pipes shown on the Plans to be laid on a curve shall be placed in strict conformance with the alignment and grade determined by marker stakes set by the District Engineer. Unless

otherwise shown on the Plans, curvature shall be accomplished by straight line runs of pipe connected by angle fittings prefabricated by the pipe manufacturer. Deflection at individual joints will not be permitted, except in cases where field conditions require unanticipated shifts in alignment or grade. Such shifts shall be accomplished at a curvature approved by the District Engineer so that the pipe joints shall be deflected no greater than the manufacturer's maximum recommended joint deflection. At locations where maximum recommended deflection angles must be exceeded, the Contractor shall install pre-manufactured angles as approved by the District Engineer. Unanticipated premanufactured angle fittings will be paid for at the unit price bid for fittings. If no bid item is provided therefor, unanticipated angles will be measured in length and paid for at the unit price bid per linear foot of pipe, and no additional payment will be made therefor, including any down time awaiting arrival of the required angle fittings

14.5 Protection of Pipe

The Contractor shall exercise every precaution against damage to the pipe, including damage from subsequent backfill or compaction operations. Any damaged pipe shall be removed from the work or repaired as directed by the District Engineer. The requirements of this Section 14.5 shall not relieve the Contractor of the provisions of Section 1.7, "Contractor's Responsibility for Work and Materials".

14.6 Testing

Where specified in the Special Provisions, or as required by the District, or when directed by the District Engineer, PP Plastic Pipe shall be tested for deformation and leakage, and video inspected for line, grade, damage, and debris. All tests shall be performed by the Contractor using methods specified in this Section 14, "Polypropylene (PP) Plastic Pipe", or as specifically approved by the District Engineer.

Any portion of the pipeline failing any of the tests or video inspection shall be dug up and repaired/replaced/re-laid. Failed locations shall be re-tested and re-videoed. Where testing or video inspection are not shown on the Plans or specified in the Special Provisions, they shall be at the discretion of the District Engineer; any one or any combination, including all three, of the tests and video inspection may be required. All tests and video inspection shall be conducted after trenches have been backfilled and compacted, but before trench resurfacing. Tests and video inspections, when required by the Special Provisions or the District Engineer to be furnished by the Contractor, shall conform to the following:

Deformation testing shall be by mandrel or rigid ball method in accordance with Section 306- 1.2.12, "Field Inspection for Plastic Pipe and Fittings", of the "Greenbook" Standard Specifications for Public Works Construction, as amended. Deformation shall not exceed five (5) percent of the internal pipe diameter. The deformation test shall be conducted at the latest time possible before trench resurfacing to allow maximum deformation to occur.

Testing for leakage shall conform to the requirements described in Section 16.1, "Acceptance Tests for Buried RGRCP and PP Plastic Storm Piping".

Where deformation and/or hydrostatic tests are specified or are required by the District Engineer, in lieu of these tests, the Contractor may, with the approval of the District Engineer, elect to place slurry cement initial backfill conforming to Section 14.3.6, "Slurry

Cement Haunching, Initial Backfill". The video inspection may still be required. No additional payment will be made for the alternative method of initial backfill.

When any test or combination of tests prescribed by this Section 14.6, "Testing", are required on the Plans or specified in the Special Provisions, the cost thereof shall be paid for as provided in the Special Provisions. If any test or combination of tests are required by the Plans or the Special Provisions and no method of payment is prescribed in either, the cost thereof shall be considered as included in the price bid for PP Plastic Pipe, and no additional payment will be made therefor. All retests shall be performed at the expense of the Contractor, including any retests where the cost of the initial tests was included in the price of the PP Plastic Pipe.

When any test or combination of tests prescribed in this Section 14.6, "Testing", are required by the Plans, Special Provisions, or the District Engineer, unless otherwise specified in the Special Provisions or specifically approved by the District Engineer in writing, no partial or other payment will be made for PP Plastic Pipe until the test or tests so required have been successfully completed and accepted by the District Engineer.

14.7 Measurement and Payment

The length of PP Plastic Pipe to be paid for will be the horizontal length measured by the District Engineer exclusive of structures, except that pipe placed in sloped areas of retention basins or other substantially inclined surfaces, measurement shall be based on slope lengths, exclusive of structures. When pipes enter a structure at an angle different from a right angle and are cut to conform to the faces of the structure or of a slope, the quantity to be paid for will be measured along the center line of the pipe to the inside face of the structure, or to the face of the slope.

15 REINFORCED CONCRETE PIPE (RCP)

15.1 General

This Work shall consist of furnishing all labor, materials, tools and equipment for installing Reinforced Concrete Pipe (RCP) at the locations shown on the Plans and specified in the Special Provisions, and in accordance with these Specifications and as directed by the Engineer. RCP shall be of the size, joint type, and strength class shown on the Plans or specified in the Special Provisions. The pipe strength class, as designated on the Plans, has been determined for vertical load under average trench conditions.

15.2 Materials, Pipe

Unless otherwise shown on the Plans or specified in the Special Provisions, or unless otherwise required by a permit issued by a jurisdictional agency, RCP to be installed in the Work shall conform to ASTM Designation: C 76, as amended or revised. Upon request, the Contractor shall furnish to the Engineer a Certificate of Compliance from the manufacturer of the pipe.

15.2.1 Pipe Substitutions

Certain pipes of other manufactures may be permitted, as provided below, to be used in lieu of RCP eighteen (18) inches in diameter. In any such case, the diameter of the substituted pipe shall not exceed eighteen (18) inches unless otherwise approved by the District Engineer in writing.

HP Plastic Pipe conforming to Section 14, "High-Performance Polypropylene (HP) Plastic Pipe", shall be substituted for RCP eighteen (18) inches in diameter only where shown on the Plans or specified in the Special Provisions or approved by the District's Engineer as a permitted substitution, unless otherwise specifically approved by the District's Engineer in writing. The substituted HP Plastic Pipe shall equal or exceed the load bearing capacity of the RCP.

15.3 Materials, Joints

The ends of RCP sections shall be of such design that when properly laid they shall have a smooth and uniform interior surface. Both ends of pipe sections shall be substantially free of cracks and broken edges. Pipe so found to be damaged shall be rejected for use in the Work. Each joint shall be sealed to prevent leakage and shall be either rubber gasket or cement mortar as indicated on the Plans.

15.3.1 Cement Mortar Joints

The joint shall comply with Standard Detail D-3. The ends of the concrete pipe shall be *thoroughly* wetted and cleaned prior to the application of mortar.

The ends of the pipe, after being wetted and cleaned, shall be completely filled with mortar for the full periphery of the joint. The two sections to be joined shall be firmly placed together in such a manner that the bell or groove end of the pipe fits truly and snugly over the tongue end with maximum joint overlap at all points around the joint periphery. Concrete shall completely fill any space or gap within the joint. The interior surface of the pipe at the joint shall be brushed smooth and all surplus mortar removed. The completed surface of the joint on the interior of the pipe shall be flush with the pipe walls.

An external mortar band at least four (4) inches wide and three-fourths (³/₄) inch thick shall be applied to the pipe, centered on the joint, by first thoroughly cleaning and wetting the areas immediately adjacent to the joint and placing mortar around the upper two hundred seventy (270) degrees of the pipe at the joint. The width and thickness of the external band shall be completely and immediately covered with an impervious membrane which shall be adequately anchored.

In no case shall water be allowed to rise in or about the pipe before the mortar of the joint has become thoroughly set.

15.3.2 Rubber-Gasket Joints

Rubber-gasket joints shall conform to the requirements of ASTM Designation: C 443. Joints shall be flexible, watertight, and able to withstand expansion, contraction and settlement. Rubber Gasket Joints shall be adequate to withstand internal hydrostatic pressures up to thirteen (13) psi, or thirty (30) feet of pressure head, without leakage when tested in accordance with said ASTM Designation: C 443.

Rubber Gaskets (Elastomeric Seals) shall conform to ASTM C 1619. The gasket class shall be appropriate for the pressure requirements of the particular pipe application, and shall be oil resistant.

The ends of the rubber gasket pipe shall be thoroughly cleaned immediately prior to joining sections of pipe. The rubber gasket shall be lubricated per the pipe manufacturer's recommendations. The two sections joined shall be firmly placed together in such a manner that the tongue or gasket end of the pipe "homes" in the bell end of the pipe. No appreciable gap shall exist at the completed joint. Excessive gaps in any case shall be cause for rejection of the work, and corrective measures shall be taken when ordered by the Engineer

15.4 Installation

RCP shall be installed in accordance with Standard Detail D-1

15.4.1 Excavation

The contractor shall exercise precautionary measures during trenching operations against trench cave-ins by providing adequate shoring or other devices to minimize the development of adversely wide trench conditions in the pipe zone.

In trenches where rock, hardpan, wet, spongy, or other material unsuitable for pipe bedding is encountered in the trench bottom, as determined by the Engineer, the unsuitable material shall be over-excavated for the type of material encountered. The over-excavated space shall be backfilled with bedding as identified in Standard Detail D-1

15.4.2 Bedding

Bedding for RCP shall be furnished and placed in accordance with Standard Detail D-1, in the price paid for RCP, and no additional payment will be made therefor.

15.4.3 Pipe Laying

Pipes shall be laid in conformity with the prescribed lines and grades obtained from survey stakes set by the Engineer. The pipe shall be laid uphill from structure to structure with

the bell end up-grade unless otherwise permitted by the Engineer. Pipe with elliptical reinforcement shall be placed with the minor axis in a vertical position. Adjustments of pipes to line and grade shall be made under the body of the pipe throughout its entire length and not by blocking or wedging. Bell holes shall be accurately placed and shall not be larger than is reasonably required to make the joint. Before the pipe is laid, the interior of the bell of the preceding pipe shall be carefully cleaned. After each section of pipe has been laid to line and grade, it shall be joined to the preceding section. After jointing procedures have commenced, there shall be no movement of the pipe whatsoever in subsequent operations. Material shall be placed uniformly on either side of the pipe to prevent any movement.

15.4.4 Construction Joints

Reference is made to the Standard Detail D-3. Whenever two sections of pipe are to be connected where standard joints are not available, such as joining reinforced concrete pipe to cast-in-place concrete pipe or plastic pipe, or in cases where field conditions are encountered which require a pipe joint to be deflected at an angle exceeding the manufacturer's maximum recommended deflection and the Engineer approves the use of a construction joint, an external concrete collar shall be constructed around the full periphery of the pipe and extending one (1) foot on both sides of the joint. The collar shall be of a minimum thickness equal to that of the concrete pipe wall, but in no case less than four (4) inches thick. The interior of the joint shall be smoothed with cement mortar and brushed. The area to receive the collar shall be thoroughly cleaned and dampened immediately prior to construction of the collar.

15.4.5 Initial Backfill and Compaction

Initial Backfill shall be placed and compacted from the top of bedding where it is installed, to one (1) foot above the outside top of pipe.

15.4.6 Minimum Cover (Depth)

Unless otherwise shown on the Plans or specified in the Special Provisions, where it is necessary to deviate from the pipe elevations shown on the Plans, as determined by the Engineer, RCP shall be placed such that the minimum cover over the pipe shall be three (3) feet, as measured from the lowest finish roadway elevation or ground surface elevation for non-roadway installations, except that within retention basins, the minimum cover over the pipe shall be four (4) feet. In cases where the minimum cover over the pipe as above specified may be reduced to less than the specified amounts, the Contractor shall provide and place a higher strength class of pipe and/or bedding shown on Standard Detail D-2.

15.5 Alignments

Pipes will be point to point and not curved. No radius or pulling joints allowed. In cases where field conditions require unanticipated shifts in alignment, said shift shall be accomplished by adding a manhole.

15.6 Protection of Pipe

The Contractor shall exercise every precaution against damage to the pipe, including damage from subsequent backfill or compaction operations. Any damaged pipe shall be removed from the Work or repaired as directed by the Engineer.

15.7 Video Inspection

Where specified in the Special Provisions, or where directed by the Engineer, the Contractor shall furnish a closed-circuit television inspection of the interior of the newly installed RCP. The pipe shall be video inspected for line, grade, joint integrity, damage, and debris. Any portion of the pipeline failing any one of the foregoing criteria shall be repaired, replaced or re-laid, or cleaned as directed by the Engineer. Failed locations shall be re-videoed. Video inspections, when required, shall be conducted after trenches have been backfilled and compacted, but before the replacement of permanent AC pavement. A DVD disc showing the initial video inspection, as well as any subsequent video inspections, shall be furnished to the District at no cost. All costs for providing Video Inspection shall be included in the price bid per lineal foot of RCP, and no additional payment will be made therefor.

15.8 Measurement and Payment

The length of Reinforced Concrete Pipe (RCP) to be paid for will be the horizontal length measured by the Engineer exclusive of structures, except that pipe placed in sloped areas of retention basins or other substantially inclined surfaces, measurement shall be based on slope lengths, exclusive of structures. When pipes enter a structure at an angle different from a right angle and are cut to conform to the faces of the structure or of a slope, the quantity to be paid for will be measured along the center line of the pipe to the inside face of the structure, or to the face of the slope.

16 STANDARD SPECIFICATIONS FOR STORM DRAIN

16.1 Acceptance Tests for Buried RGRCP and PP Plastic Storm Piping

- 16.1.1 All newly installed section of buried RGRCP and PP pipe shall be pressure and leakage tested as described herein.
- The water level in the upstream standpipe shall be maintained at the design high water level for a period of no less than 2 hours.
 - The allowable leakage under working conditions for RGRCP pipe shall not exceed 250 gallons per 24 hours per inch of pipe diameter, per mile of gravity pipeline tested.
- 16.1.2 Tests shall be made after the trench has been backfilled and compacted, but not until at least 5 days have elapsed since any thrust blocks or concrete collars in the section have been placed.
- 16.1.3 Slowly fill the pipe with water at a rate such that the velocity does not exceed 0.25 foot per second and allow the water to stand for a minimum of 24 hours prior to starting the test. Expel all air from the pipe. Absorption by the pipe or pipe lining material may require a longer period before beginning the test, as directed by the Owner.
- 16.1.4 Should testing disclose any visible leaks or leakage greater than that allowed, the defective joints or pipe shall be located, repaired and re-tested to sole satisfaction of Owner until satisfactory results are obtained by the Contractor at his expense.
- 16.1.5 Water for testing shall be supplied by Owner as detailed at Section 1.17.

17 STANDARD SPECIFICATIONS FOR EARTHWORK (PIPELINES)

17.1 General Conditions

17.1.1 Earthwork Defined

Earthwork shall include all necessary clearing, grubbing, grading, and excavation of all classes and of whatever substance encountered, backfilling, compaction, cleaning up debris, papers, and loose rocks, restoring fences and other disturbed property, maintaining trees which are not permitted to be removed, and disposing of excess excavated material, all as required for the complete performance of the work for the installation of the facilities and appurtenances indicated on the Plans and specified herein. Included is controlling ground water and storm water runoff, bracing excavations, stabilizing subgrade, protecting existing structures and facilities and such supplementary operations as are necessary to properly complete the entire work indicated or specified.

17.1.2 Earthwork in State, County, Railroad, and RCWD Rights-of-Way

Earthwork within the rights-of-way of the State Department of Transportation and the Madera Public Works Department shall be in accordance with requirements and provisions of any permits issued by those agencies for the construction within their respective rights-of-way. Such requirements and provisions, where applicable, shall take precedence and supersede the provisions of these Specifications.

17.1.3 Relative Compaction

Relative Compaction specified herein shall be a percentage of the maximum density at optimum moisture content as determined by ASTM Test Method No. 1557 (sand cone). Unless otherwise specified, the minimum relative compaction for earthwork in open fields shall be 85%. In populated areas and in public and private roads and driveways the relative compaction shall be as shown on Standard Drawings D-1, D-2, S-1, S-2, or W-1, W-2.

17.1.4 Safety Precautions

All excavations shall be performed, protected and supported as required for safety and in the manner set forth in the operation rules, orders and regulations prescribed by the Division of Industrial Safety of the State of California. Barriers shall be placed at each end of the excavations and at such places as may be necessary along excavations to warn all pedestrian and vehicular traffic of such excavations. Lights shall also be placed along excavations from sunset each day to sunrise of the next day until such excavation is entirely refilled.

17.1.5 Obstructions

The Contractor's attention is directed to the possible existence of pipe and other underground improvements which may or may not be shown on the Plans. The Contractor shall preserve and protect any such improvements whether shown on the Plans or not. Where it is necessary to remove and replace or to relocate such improvements in order to prosecute the work, they shall be removed, maintained, and permanently replaced by the Contractor at his expense.

17.1.6 Dewatering

The Contractor shall provide and maintain at all times during construction ample means and devices with which to promptly remove and properly dispose of all water from any source entering the excavation or other parts of the work. Dewatering shall be accomplished by methods which will ensure a dry excavation and preservation of the final lines and grades of the bottoms of excavations. Said methods may include well points, sump joints, suitable rock or gravel placed below the required bedding for drainage and pumping purposes, temporary pipe lines and other means that will not be detrimental to the proposed construction.

Dewatering for the structures and pipelines shall commence when groundwater is first encountered, and shall be continuous until such time as water can be allowed to rise in accordance with the provisions in this Section. No concrete footings or floors shall be laid in water nor shall water be allowed to rise over them until the concrete or mortar has set at least eight (8) hours. Water shall not be allowed to rise unequally against walls for a period of twenty-eight (28) days. Groundwater shall not be allowed to rise around the pipe until jointing compound in the joints has set hard.

The Contractor shall dispose of water from the work in a suitable manner without damage to adjacent property. No water shall be drained into work built or under construction without prior consent of the District's Representative. Water shall be disposed in such a manner as not to be a menace to the public health.

17.1.7 Bracing Excavations

Excavations shall be so braced or sheeted as to provide conditions under which workmen may work safely and efficiently at all times. Rules, orders and regulations of the Division of Industrial Safety of the State of California shall be complied with. Excavations shall be so braced, sheeted and supported that the ground alongside the excavation will not slide or settle, and all existing improvements of any kind, either on public or private property, will be fully protected from damage. The sheeting, shoring and bracing shall be so arranged as not to place any stress on portions of the completed work until the general construction thereof has proceeded far enough to provide ample strength. Any damage to structures occurring through settlements, water or earth pressures, slides, caves or other causes due to failure or lack of sheeting or bracing, or improper bracing, or through negligence or fault of the Contractor in any other manner, shall be repaired by the Contractor at his own expense.

Care shall be exercised in the drawing or removal of sheeting, shoring, bracing, and timbering to prevent the caving or collapse of the excavation faces which are being supported and in such a manner as to prevent additional backfill that might overload the pipe or conduit. All expenses of sheeting and shoring as herein specified shall be included in the various contract prices and no additional allowance will be made therefore.

17.2 Materials and Workmanship

17.2.1 Clearing and Grubbing

All brush, roots, vegetation, rubbish, debris and other deleterious material shall be removed and disposed of so as to leave the construction site clean and neat.

17.2.2 Trench Width

Trench widths measured at a level of one foot above top of pipe, pipelines and appurtenances shall not exceed the limits listed in the following table:

Nominal Inside Pipe Diameter	Minimum Trench Width	Maximum Trench Width
4" - 12"	O.D. plus 12"	O.D. plus 18"
14" - 30"	O.D. plus 18"	O.D. plus 24"

Where shoring or encasement is required, trench widths shall be established by the District's Representative. If the trench width, measured at a point twelve inches (12") above the top of the barrel of the pipe, is wider than the maximum set forth above, it may be necessary to backfill the trench area around the pipe with five-sack concrete to encase or form a cradle to protect the pipe. The District's Representative shall specify when said encasement or cradle is necessary.

17.2.3 Trench Depth

Trench depth shall be adequate to accommodate the pipe and its foundation at the profile shown on the Plans. In the absence of such profile grade, the top of pipe grade shall be located three feet (3') below the existing street grade or existing ground. The measurement of the depth shall be at the trench centerline.

Where the natural ground above the pipeline trench has been over excavated and/or the pipeline is to be placed in new embankment, embankment material shall be placed and compacted to an elevation of not less than three feet (3') above the top of pipe prior to trench excavation.

17.2.4 Pipe Subgrade

Pipe subgrade at the trench bottom shall have a flat or semi-circular cross section. The bottom of the trench for pipe shall be graded and prepared to provide a firm and uniform bearing throughout the entire length of each joint except for required "bell holes" at joints. Pipe shall not be laid on earth mounds and care must be taken to avoid creating earth mounds with the material excavated from "bell holes."

17.2.5 Foundations in Poor Soil

Foundations in poor soil shall be constructed by removing sufficient soft, spongy and deleterious material below pipe bottom grade and replacing it with sand or crushed rock, as selected by the District's Representative, to obtain a firm subgrade. The replacement of unsound materials to depths of up to two feet (2') below bottom of pipe grade shall be considered to be included in the installed pipe bid price. The necessity of replacing unsuitable material at depths of more than two (2) feet below bottom of pipe grade will be determined by the District's Representative and will be specifically ordered as provided in the extra work provisions of these Specifications. However, if the necessity for such additional removal and replacement has been occasioned by an act or failure to act on the part of the Contractor, the Contractor may be required to bear the expense of the additional excavation and backfill to the required depth.

17.2.6 Correction of Faulty Grades

All excavations carried below pipe grade shall be backfilled to proper grade and cross section with sand compacted to a minimum relative compaction of 90%.

17.3 Backfill

All trenches and excavations shall be backfilled after pipe, fittings, valves and appurtenances have been installed.

17.3.1 Procedure in Pipe Zone

The pipe zone shall be considered to extend from the bottom of the excavation to twelve inches (12") above the top of the pipe.

Native soil material may be used for backfill in the pipe zone only if it meets the conditions below for pipe zone imported backfill.

17.3.2 Imported Backfill Material

The imported backfill material for pipe, fittings, and anchor walls shall consist of clean washed sand having a sand equivalent value of not less than 50, as determined by California Test Method No. 217.

Backfill shall be placed in layers simultaneously on each side of the pipe for the full width of the trench. Sand may be placed and compacted in layers up to 12 inches in compacted thickness. All other material shall be placed and compacted in layers not exceeding 6 inches in compacted thickness. In placing and compacting the backfill, particular attention is to be given to the underside of the pipe and fittings to provide a firm support along the full length of the pipe. Care shall be exercised in backfilling to avoid damage to any pipe coating.

17.3.3 Procedure Above Pipe Zone

Material shall not be placed in this zone until approval has been given for placement of pipe zone backfill. From the top of the pipe zone to the ground surface or finish grade, the material for backfill shall be native soil and may contain stones up to 3 inches in diameter, but shall be so graded that at least 40% of the material passes a No. 4 sieve. The coarser materials shall be well- distributed throughout the finer material. Backfill material shall be placed in layers of a thickness which can be consolidated throughout to the specified density with equipment which will not damage the pipe on fittings and as limited by these Specifications.

17.3.4 Tracer Tape

Contractor shall install metallic tracer wire attached to the top of all water, sewer, and storm drain pipes. Tracer wire coverage shall be continuous (i.e. there shall be no part of the trench without wire.)

17.4 Compaction

All backfill shall be consolidated throughout by tamping and/or water settling to a minimum relative compaction as shown on Standard Drawings D-1, D-2, S-1, S-2, W-1, and W-2 or the density required by the agency in whose right-of-way the work is located, whichever is higher.

Backfill material shall be placed in uniform layers of the thickness specified above. To be considered a passing test, all compaction tests must meet the required relative percent compaction and must indicate a moisture content of optimum but no more than 4% of optimum. Each layer shall be tamped until compacted to the required minimum relative compaction. Compacting equipment having an overall weight in excess of 100 pounds shall not be used until backfill has been completed to a depth of two (2) feet over the top of the pipe. The selection and use of compaction equipment will be such that compaction requirements will be met without damage to the facilities.

Compaction by flooding and/or jetting will be allowed only with the approval of the District's Representative and will not be allowed when natural groundwater level is at or above the level of the trench bottom.

17.4.1 Compaction Tests

Compaction tests will be made by a recognized laboratory designated by the District's Representative. The number of tests and their location and depths shall be determined by the District's Representative. The Contractor shall make all necessary excavations for compaction tests, as directed by the District's Representative, and shall refill and re-compact these excavations to the densities as specified herein.

17.4.2 Compaction Testing Frequency

- Approximately 100' on center.
- First Test – bottom of over-excavation
- Maximum center and elevation spacing testing tolerance is 25% (maximum testing spacing is 125' on center and elevation is 2.5' centers).
- Per Standards upper 5' are 90% and top 2.5' 95% relative compaction.
- If expansive soils are encountered, refer to Geotechnical Report for compaction requirements.

17.4.3 Compaction Reporting Requirements

- Reports shall be prepared and PDF versions are to be emailed on a weekly basis to:
Steve Spencer Spencer@ppeng.com
Julia Berry Julia@rootcreedwd.com
Shay Bakman shay@bakmanwater.com
Brian Partridge Brian@bakmanwater.com
James Parker jp@bakmanwater.com
- .
- Reports shall be labeled Root Creek Water District, "Name of Project"
- Reports shall include compaction tests results, point map, and be certified.
- At the conclusion of the project, the weekly reports shall be resubmitted along with a summary report and certification.

17.4.4 Final Clean-up

After backfill has been completed, the right-of-way shall be dressed smooth and left in a neat and presentable condition, free of all cleared vegetation, rubbish, and other

construction wastes. Surplus rock which cannot be used for backfill shall be hauled away and disposed of by the Contractor.

18 STANDARD SPECIFICATIONS FOR EARTHWORK (STRUCTURES AND MISCELLANEOUS PIPING)

18.1 General Conditions

18.1.1 Scope of Work

Earthwork shall include all necessary clearing, grubbing, grading, and excavation of all classes and of whatever substance encountered, backfilling, compaction, cleaning up debris, papers and loose rocks, restoring fences and other disturbed property, maintaining trees which are not to be removed and disposing of excess excavated material all as required for the complete performance of the work for the installation of the facilities and appurtenances indicated on the Plans and specified herein. Included is controlling groundwater and storm runoff, bracing excavations, stabilizing subgrade, protecting existing structures and facilities, and such supplementary operations as are necessary to properly complete the entire work indicated or specified.

18.1.2 Earthwork in State and County Rights-of Way

Earthwork within the rights-of-way of the State Department of Transportation and/or the County Road Department shall be in accordance with requirements and provisions of any permits issued by those agencies for construction within their respective rights-of-way. Such requirements and provisions, where applicable, shall take precedence and supersede the provisions of these specifications.

18.1.3 Relative Compaction

Relative compaction specified herein shall be a percentage of the maximum density at optimum moisture content as determined by ASTM Test Method D1557 (sand cone).

18.1.4 Safety Precautions

All excavations shall be performed, protected and supported as required for safety and in the manner set forth in the operational rules, orders and regulations prescribed by the Division of Industrial Safety of the State of California. Barriers shall be placed at each end of all excavations and at such places as may be necessary along excavations to warn all pedestrian and vehicular traffic of such excavations. Lights shall also be placed along excavations from sunset each day to sunrise of the next day until such excavation is entirely refilled.

18.1.5 Obstructions

The Contractor's attention is directed to the possible existence of pipes and other underground improvements which may or may not be shown on the Plans. The Contractor shall preserve and protect any such improvements whether shown on the Plans or not. Where it is necessary to remove and replace or relocate such improvements in order to prosecute the work, they shall be removed, maintained and permanently replaced by the Contractor at his expense.

18.1.6 Surplus Excavated Material

Surplus excavated material shall be placed in the areas shown on the Plans. Any materials that cannot be disposed of within the limits of areas shown, or where no disposal

areas are shown, shall be disposed of legally off-site by and at the expense of the Contractor.

18.1.7 Imported Backfill Material

Whenever the excavated material is not suitable for backfill, the Contractor shall arrange for and furnish suitable imported backfill material at his own expense.

18.1.8 Working Area

Except for specified off-site construction, all earthwork shall be confined strictly within site property lines or rights-of-way.

18.1.9 Compaction Tests

Compaction tests will be made by a laboratory designated by the District's Representative. The number of tests and their location and depth shall be determined by the District's Representative. The Contractor shall make all necessary excavations for compaction tests as directed by the District's Representative, and shall refill and recompact these excavations to the densities as specified herein.

Compaction tests are also required and charged to the Contractor under various road and encroachment permits. This section in no way relieves the Contractor of obligations incurred under these permits.

18.1.10 Bracing Excavations

Excavations shall be so braced or sheeted as to provide conditions under which workmen may work safely and efficiently at all times. Rules, orders and regulations of the Division of Industrial Safety of the State of California shall be complied with. Excavations shall be so braced, sheeted and supported that the ground alongside the excavation will not slide or settle, and all existing improvements of any kind, either on public or private property, will be fully protected from damage. The sheeting, shoring, and bracing shall be so arranged as not to place any stress on portions of the completed work until the general construction thereof has proceeded far enough to provide ample strength. Any damage to structures occurring through settlements, water or earth pressures, slides, caves or other causes due to failure or lack of sheeting or bracing or improper bracing or through negligence or fault of the Contractor in any other manner shall be repaired by the Contractor at his own expense.

Care shall be exercised in the drawing or removal of sheeting, shoring, bracing and timbering to prevent the caving or collapse of the excavation faces which are being supported, and in such a manner as to prevent additional backfill that might overload the pipe or conduit.

18.1.11 Grading and Stockpiling

The Contractor shall control grading in a manner to prevent surface water running into excavations. Obstruction of surface drainage shall be avoided and means shall be provided whereby storm and water can flow uninterrupted in existing gutters, other surface drains or temporary drains. Material for backfill or for protection of excavation in public roads from surface drainage shall be neatly placed and kept shaped so as to cause the least possible interference with public travel. Free access must be provided to all fire hydrants, water gates, meters and private drives.

18.1.12 Dewatering

The Contractor shall provide and maintain at all times during construction ample means and devices with which to promptly remove and properly dispose of all water from any source entering the excavation or other parts of the work. Dewatering shall be accomplished by methods which will ensure a dry excavation and preservation of the final lines and grades of the bottoms of excavations. Said methods may include well points, sump points, suitable rock or gravel placed below the required bedding for drainage and pumping purposes, temporary pipe lines and other means that will not be detrimental to the proposed construction.

Dewatering for the structures and pipelines shall commence when groundwater is first encountered and shall be continuous until such times as water can be allowed to rise in accordance with the provisions in this Section. No concrete footings on floors shall be laid in water nor shall water be allowed to rise over them until the concrete or mortar has set at least eight (8) hours. Water shall not be allowed to rise unequally against walls for a period of twenty-eight (28) days. Groundwater shall not be allowed to rise around the pipe until jointing compound in the joints has set hard.

The Contractor shall dispose of water from the work in a suitable manner without damage to adjacent property. No water shall be drained into work built or under construction without prior consent of the District's Representative. Water shall be disposed in such a manner as not to be a menace to the public health.

18.1.13 Correction of Faulty Grades

Where excavation is inadvertently carried below subgrade and/or foundation elevations, it shall be rectified by backfilling with approved sand, compacted to provide a firm and unyielding subgrade, and/or four- sack concrete, as directed by the District's Representative, all at the expense of the Contractor.

18.2 Grading

18.2.1 Stripping

All vegetation, such as roots, brush, heavy sods, heavy growth of grass and all decayed vegetable matter, rubbish, and other unsuitable material within the area of the work shall be stripped or otherwise removed prior to starting excavation and embankment.

18.2.2 Excavation

After stripping has been done, excavation of whatever substances are encountered within the grading limits of the work shall be performed to the lines and grades indicated on the Drawings. All suitable excavated material shall be transported to and placed in the fill areas within the limits of the work. Material not suitable for embankment shall be legally disposed of off-site by the Contractor.

18.2.3 Fill

Areas to receive fill material shall be scarified and benched in order to allow new material to bond with the existing soil. Fills or embankments shall be constructed at the locations and to the lines and grades indicated on the Drawings. Suitable material from excavation may be used for fill. Material shall be placed in horizontal layers not to exceed 6 inches

compacted depth for the full width of the cross section and compacted as specified. Fill slopes shall not exceed 2:1.

Haul routes shall be planned to avoid passing heavy equipment over pipelines with less than six feet of cover. Where crossings must be made, the Contractor shall provide concrete encasement or approved bridging.

Embankments under pavement or structures shall be compacted to at least 95 percent of maximum density. Other embankments shall be compacted to at least 90 percent of maximum density.

18.2.4 Finish

All areas covered by the work, including excavated and filled sections and transition areas, shall be uniformly graded to the elevations shown on the Plans. The finished surface shall be reasonably smooth, compacted, and free from any irregular surface changes. Edges of spoil and borrow areas shall be rounded to blend into natural contours. The degree of finish ordinarily obtainable from either blade grader or scraper operations will be satisfactory for open areas but hand grading and raking will be required around structures and walkways. The finished surface shall be not more than 0.2 feet above or below the established grade and sloped to prevent ponding.

18.3 Soil Sterilant

18.3.1 General

The Contractor shall treat the finished subgrade of specified areas with an approved soil sterilant.

18.3.2 Areas Requiring Soil Sterilant

- All bitumastic-paved embankments, walkways, drainage structures, parking, and road areas.
- All storm drainage pond interior surface embankments.
- All exterior embankment surfaces where paved.
- All perimeter areas (tops of berms).

18.3.3 Material and Application

The sterilant shall be a combination of sodium chlorate and borates similar and equal to Polybor-Chlorate, as manufactured by the Pacific Coast Borax Company. The sterilant shall be applied in a liquid or dry form and at a uniform rate of not less than 8 ounces of dry sterilant per square yard, in accordance with the manufacturer's directions. At the option of the District's Representative, the area shall then be lightly sprinkled with water to prevent loss of sterilant or scuffing.

18.4 Structure Excavation and Backfill

18.4.1 General

Structure excavation shall include the removal of all material of whatever nature necessary for the construction of structures and foundations in accordance with the Plans and Specifications. It shall include the furnishing of all labor, materials, tools, and

equipment and doing all the work involved in the installation and subsequent removal of all shoring, sheeting, bracing, and other details which may be necessary.

18.4.2 Working Clearance

The sides of excavations for structures shall be sufficient to leave at least two feet (2') in the clear as measured from the extreme outside of form work or the structure, as the case may be.

18.4.3 Excessive Excavation

Ground shall not be dug by machinery utilizing teeth nearer than three (3) inches from any finished subgrade. The last three inches shall be removed without disturbing the subgrade. Should the excavation be carried below the lines and grades indicated on the Drawings, the Contractor shall refill such excavated space to the proper elevation with imported sand compacted to structural standards or, if under footings, the space shall be filled with four-sack concrete.

Excavation shall extend a sufficient distance from walls and footings to allow for placing and removal of forms, installation of services, and for inspection, except when concrete is authorized to be placed directly against excavated surfaces.

18.4.4 Structure Backfill

After structures and foundations are in place, backfill shall be placed to the original ground line or to the limits designated on the Plans. No material shall be deposited against the walls of concrete structures for a period of fourteen (14) days following pouring of concrete.

18.4.5 Compaction

Backfill shall be placed in horizontal layers not exceeding six inches (6") in depth and shall be moistened and thoroughly tamped, rolled, or otherwise compacted to a minimum relative density of ninety-five percent (95%). Water settling will be permitted at the option of the District's Representative. Backfill shall be placed in such way that no additional unbalanced loading may occur during placing.

Particular care shall be exercised when backfilling at the various structures to obtain adequate compaction beneath pipes connected thereto and to avoid injury or displacement of such pipes. A minimum of two compaction tests will be required at each structure. One at the level of the concrete base and another midway from the base to the top of the structure.

18.4.6 Materials

Backfill shall consist of loose earth or sand free from stones, clods, or other deleterious material. When material from the excavation is unsuitable for use in backfill, it shall be disposed of and suitable material furnished by the Contractor.

18.4.7 Surplus Excavated Material

Surplus material from the excavation remaining after backfilling shall be disposed of as specified for "Excess Excavated Material" above.

18.5 Final Clean-Up

After backfill has been completed, the site shall be dressed smooth and left in a neat and presentable condition, free of all cleared vegetation, rubbish and other construction wastes. Surplus rock which cannot be used for backfill shall be hauled away and legally disposed. Areas next to structures where blade-type equipment cannot reach shall be hand-raked.

19 STANDARD SPECIFICATION FOR ASPHALT CONCRETE PAVEMENT

19.1 Aggregate Sub-base

19.1.1 General

Aggregate sub-base shall consist of mineral aggregate, spread and compacted on a prepared subgrade in conformance with the lines, grades, and dimensions shown on the plans, the Standard Details, and these Standard Specifications.

19.1.2 Material

Aggregate sub-base material shall be Class 2, shall be free of vegetable matter and other deleterious substances, and shall conform to the provisions of Section 25 of the State Standard Specifications. Aggregate sub-base shall be compacted to ninety-five percent (95%) relative compaction as determined by ASTM 1557.

19.2 Aggregate Base

19.2.1 General

Aggregate base material shall consist of mineral aggregate, spread and compacted on a prepared subgrade in conformance with the lines, grades, and dimensions shown on the plans, the Standard Details, and these Standard Specifications.

19.2.2 Material

Aggregate base material shall be Class 2, shall be free of vegetable matter and other deleterious substances, and shall conform to the provisions of Section 26 of the State Standard Specifications. Aggregate base shall be compacted to ninety-five percent (95%) relative compaction as determined by ASTM 1557.

19.2.3 Additional Thickness

In the event that on-site soil conditions are such that a satisfactory subgrade cannot be prepared, additional material below the subgrade grading plane shall be removed. The native material shall be replaced by additional Class 2 aggregate base or Class 2 aggregate sub-base, at the option of the Contractor, and shall be compacted in accordance with the provisions of this section.

19.3 Asphalt Concrete

19.3.1 General

Asphalt concrete shall consist of mineral aggregate blended with bituminous binder at an approved central mixing plant, in accordance with the requirements of Section 39 of the State Standard Specifications and these Standard Specifications.

19.3.2 Aggregate Materials and Gradation

All aggregates used for asphalt concrete shall be clean and free from vegetable or other deleterious matter. Aggregate gradations shall conform to those set forth in Section 39-2.02 of the State Standard Specifications for 3/4" maximum, medium, or 1/2" maximum, medium, as designated on the project plans.

If the plans do not specify aggregate gradation, the following rules shall apply. All asphalt concrete surface courses shall be placed using 1/2" aggregate. If the thickness of the

asphalt course to be placed exceeds 0.20 feet, asphalt shall be placed in two lifts. The lower lift(s) shall in no case exceed 0.25 feet in thickness, and shall be placed using 3/4" material. The surface course shall be placed using 1/2" aggregate. The thickness of the surface course shall be a minimum of 0.10'.

19.3.3 Paving Asphalt

Paving asphalt shall be mixed with the mineral aggregate at a rate of between 3% and 7% by weight of the dry mineral aggregate. The exact amount of paving asphalt to be mixed with the mineral aggregate shall be subject to approval by RCWD.

Unless otherwise specified on the plans and approved by RCWD, paving asphalt shall be AR-4000.

19.4 Asphaltic Paint Binder

Asphaltic paint binder shall be applied as a tack coat to all vertical surfaces of existing pavement, concrete curbs, gutters, construction joints against which additional material is to be placed and to all existing pavements which are to be overlain.

Asphaltic paint binder may be either AR-4000 paving asphalt or SS-100 asphaltic emulsion cut back 50 percent with water. The application rate shall be 0.10 gallon per square yard or as directed by RCWD.

19.5 Sand Application

Where determined by District's Representative to be necessary, sand cover shall be applied to driveways and public road approaches after application of the tack coat, to absorb excess asphaltic paint binder which has failed to penetrate the surface.

Sand for such application shall be free from organic material and clay. Sand shall be of such size and gradation that a minimum of 90 percent will pass a No. 4 sieve and not more than five percent (5%) will pass a No. 200 sieve. Sand shall be spread uniformly over the affected area to the satisfaction of District's Representative. All excess loose sand shall be removed from the treated area. The treated surface shall be maintained in smooth and satisfactory condition through the paving operation.

19.6 Spreading and Compaction of Asphalt Concrete Paving

19.6.1 General

Asphalt concrete finish courses and overlays shall be placed only when the ambient air temperature is above 50° F. Asphalt concrete base courses shall be placed only when the ambient air temperature is above 40° F.

Asphalt concrete shall not be placed during precipitation, nor when the threat of local precipitation according to the National Weather Service is greater than 70 percent, nor when, in District's opinion, the weather conditions are not or will not be suitable for the proper handling, finishing or compacting of the asphalt concrete mixtures.

Asphalt concrete more than 0.20 feet in thickness shall be placed in lifts. See the aggregate gradation requirements under Paragraph C above. The top lift shall not exceed 0.20-foot in compacted thickness. Lower lifts shall not exceed 0.25-foot in compacted thickness.

Asphalt concrete to be placed on road shoulders and other areas off of the traveled way shall be spread in the same manner as specified above. When the shoulders or other areas are less than five feet (5') in width, asphalt concrete may be placed in one or more lifts by any mechanical means that will produce uniform thickness and texture. Asphalt concrete shall not be handled, spread or windrowed in a manner that will stain the surface of existing improvements.

Longitudinal joints in the top lift of the pavement shall correspond to the edges of the proposed traffic lanes, unless such requirement is waived by the District's Representative in writing prior to the paving operation. Longitudinal joints in lower lifts shall be offset by not less than 0.5 feet from the joints in the lifts immediately above.

Unless otherwise specified, the top lift of asphalt concrete for the traveled lanes shall be placed prior to or simultaneously with placement of the top lift in adjacent areas such as left-turn lanes, parking lanes, tapers, transitions, drive approaches and so forth.

At locations which are inaccessible to spreading and rolling equipment, asphalt concrete shall be spread by any method able to achieve the specified results, and shall be compacted thoroughly with pneumatic tampers or any other method which will achieve the required degree of compaction.

19.6.2 Spreading Equipment

Spreading equipment shall conform to the requirements of Section 39-5.01 of the State Standard Specifications, which describes motor graders and self-propelled paving machines, and these Standard Specifications.

Contractor may petition RCWD for permission to use paving equipment other than that specified herein. Failure to make such a petition at least five business days prior to the start of the paving operation will be grounds for rejection of the proposed substitute equipment. RCWD may reject substitute equipment if it believes that such substitution may adversely affect the final quality of the pavement.

19.6.3 Compaction Equipment

Compaction equipment shall conform to the requirements of Section 39-5.02 of the State Standard Specifications; generally, one 8-ton steel drum roller, one 12-ton steel roller, and one pneumatic-tired roller. Each roller shall be operated by a separate operator, and all rolling equipment shall be self-propelled and reversing. Other requirements are detailed in the cited section of the State Standard Specifications.

19.6.4 Compacting Small Areas

For projects where any one of the following conditions are met, the 12-ton roller may be eliminated:

- the total quantity of asphalt to be placed is less than 1,000 tons, or
- the production rate is less than 50 tons per hour, or
- the production rate is less than 100 tons per hour and asphalt is being placed on areas other than traveled lanes, or
- the width of the asphalt is less than eight feet, or
- the total thickness is less than 0.1-foot

As an alternate to the pneumatic roller, a vibratory roller may be substituted. When a vibratory roller is used for final compaction, the vibrator unit shall be turned off.

Areas which are inaccessible to such a roller shall be thoroughly compacted to the lines, grades and cross-sections shown on the Plans by means of pneumatic tampers or other methods which will produce the same degree of compaction.

19.6.5 Grade Control

Asphalt concrete shall be finished to a smooth surface free of wrinkles, ruts, humps, depressions, and other irregularities. When a straight-edge 12 feet long is laid on the finished surface parallel to the centerline, the surface shall not vary from the edge by more than 0.01-foot. The transverse slope of the finished surface shall be uniform to the degree that no depressions greater than 0.02-feet are present when tested with a 12-foot straight-edge laid transverse to the centerline.

19.7 Finishing Roadway

Finishing Roadway shall conform to the requirements of Section 22 of the State Standard Specifications, and shall include transitions between pavement and bituminous surfaces at cross streets and alleys. The finished edge of the paving shall be flush to, or up to one-quarter inch (1/4") above the gutter lip.

19.8 Fog Seal

In general, fog seal *shall not* be applied to new asphalt concrete surfaces, unless specifically directed by District's Representative, or shown on the plans.

In the case that such direction is made, fog seal shall conform to the requirements of Section 37-1.01 of the State Standard Specifications.

Fog seal shall be mixed as one part SS-1 asphaltic emulsion, and one part added water. The mixture shall be applied to the pavement at a rate of 0.10 gallon per square yard, or as directed by the District's Representative.

SS-1 asphaltic emulsion shall conform to the requirements of Section 94 of the State Standard Specifications. Emulsion shall be homogeneous after thorough mixing.

Fog seal shall be applied by distributor spreader bar, at a temperature of 110° to 130° F. Asphaltic emulsion shall not be allowed to cool below 40° F at any time.

20 STANDARD SPECIFICATION FOR PORTLAND CEMENT CONCRETE IMPROVEMENTS

20.1 General

Portland cement concrete improvements shall be constructed in accordance with Section 73 of the State Standard Specifications and these Standard Specifications. As used herein, the term "*concrete improvements*" shall include curb, gutter, curb & gutter, sidewalk, wheel chair ramps, drive approaches, alley approaches, valley gutters and other slab concrete constructed within RCWD right-of-way.

20.2 Portland Cement Concrete

20.2.1 General

Portland cement concrete shall conform to the requirements of Section 90-10 of the State Standard Specifications, *Minor Concrete*. Portland cement concrete shall contain not less than 564 pounds (six sacks) of cement per cubic yard, unless shown otherwise on the Plans

20.2.2 Cement

Cement shall be Portland Cement Type II, Type V, or Type II-V, conforming to Section 90 of the State Standard Specifications, latest revision.

20.2.3 Strength Requirements

All Class "A" concrete shall be proportioned to attain a minimum cylinder strength of 3,000 psi in 28 days. All Class "B" concrete shall be proportioned to attain a minimum cylinder strength of 2,500 psi in 28 days. The compressive strengths are to be determined in accordance with ASTM C39. Not less than 6 sacks of cement shall be used per cubic yard of Class "A" concrete, nor less than five (5) sacks of cement shall be used per cubic yard of Class "B" concrete. All ready-mix shall comply with ASTM C94-72.

20.2.4 Aggregates

Aggregates for Portland cement concrete shall conform to Section 90-2.10 of the State Standard Specifications and shall be free from deleterious coatings, clay balls, roots, bark, sticks, and other extraneous material. Appearance of such materials in the concrete mix shall be grounds for rejection of the entire transit truck of material.

20.2.5 Aggregate Gradation

Aggregates for Portland cement concrete shall conform to the requirements of Section 90-3.04 of the State Standard Specifications, for 1-inch maximum aggregate size. Unless otherwise noted on the plans, a specific aggregate gradation submittal will not be required.

20.2.6 Admixtures

No specific admixtures are required, unless noted on the Plans. Contractor may submit a concrete design containing admixtures for review by RCWD. Such submittal shall be made at least five working days in advance of the planned concrete pour. Admixtures proposed in any such submittal shall conform to the requirements of Section 90-4 of the State Standard Specifications.

20.2.7 Calcium Chloride

Unless specifically permitted by the District's Representative, calcium chloride shall not be added to Portland cement concrete. In no case shall calcium chloride be added to concrete which will be used in structures containing steel or other embedded metals.

20.2.8 Proportioning

The exact proportions of the concrete ingredients shall be established by a material testing laboratory selected by the District's Representative. The Contractor shall notify the District's Representative of his proposed mix design and source of the aggregate in sufficient advance time to permit testing.

20.2.9 Mixing and Transporting

All Portland cement concrete for use in public works improvements shall be mixed in mechanical mixers, except that RCWD may allow batches of less than 1/3 cubic yard to be mixed by hand in accordance with Section 90-6.05 of the State Standard Specifications.

Machine mixing shall conform to the provisions of Section 90-6.02 of the State Standard Specifications. Temperature of the mix shall be maintained between 50° and 90° F at all times.

Concrete shall be transported to the project site by vehicles conforming to the provisions of Section 90-6.03 of the State Standard Specifications. Unless specifically allowed by the District's Representative, no additional mixing water shall be added to the concrete mix during hauling or after arrival at the project site. If the District's Representative does authorize such addition, the mixing drum shall be revolved not less than thirty revolutions at mixing speed after water is added and before delivery is commenced.

20.2.10 Placing

The Contractor shall notify the District's Representative 24 hours in advance of any concrete placing. Concrete shall not be placed until all form work, reinforcement, electrical conduit, installation of fixtures to be embedded and preparation of concrete surfaces to be bonded have been completed and are ready for new concrete.

Concrete surfaces on or against which other concrete is to be placed shall be thoroughly cleaned of surface latency. Clean aggregate shall be exposed as specified herein for joints.

Each concreting operation shall be continuous until the placing in the course, section or monolith is completed. Fresh concrete shall not be permitted to fall from a height greater than six (6) feet without the use of adjustable-length pipes or "tremmies."

In order to assure that there will be no interruption in such continuous placing, the Contractor shall have available standby concrete-mixing equipment ready for use in case of breakdown, or he shall make arrangements, satisfactory to the District's Representative, with the supplier of the concrete, if transit mix concrete is being used, so that the District's Representative may be assured that once placement is started it can be completed without interruption. The vibrating equipment, including standby equipment, shall be at the site and tested in the presence of the District's Representative during the day preceding the planned day of placement.

Appropriate mechanical vibration shall be used in placing concrete to eliminate stone pockets and voids, to consolidate each layer with that previously placed, to completely embed reinforcing bars and other fixtures, and to bring just enough fine material to the faces of top and exposed surfaces to produce a smooth, dense and even texture. Vibrators shall be of the high-frequency internal type. The number in use shall be ample to consolidate the incoming concrete to a proper degree within 15 minutes after it is deposited in the forms. In all cases, at least two (2) vibrators shall be available at the site. The use of external vibration for compacting concrete will be permitted when the concrete is otherwise inaccessible for adequate compaction, provided the forms are sufficiently rigid to resist displacement or damage from external vibration and the type of vibrators are approved by the District's Representative.

20.2.11 Forms

All forms shall be smooth, mortar tight, true to the required lines and grades, and of sufficient strength to resist deflection during the placing of concrete. All foreign matter shall be removed from forms before concrete is placed therein. Forms previously used shall be thoroughly cleaned before reuse. Prior to placing concrete, all forms shall be oiled with a high-penetration form oil which leaves no film that can be absorbed by the concrete. Immediately prior to placing concrete, all forms shall be thoroughly wetted.

Forms shall not be removed until the concrete has hardened sufficiently to safely support its own weight and possible construction loads. Forms supporting concrete members which are subject to direct bending stress shall not be removed or struck until concrete test cylinders shown that sufficient strength to support the required structural load has been attained. In no case, however, shall forms be removed or released prior to the passing of 24 hours following placing of the concrete.

Forms for all surfaces which will not be completely enclosed or hidden below the final surface of the ground shall be made of surfaced plywood. Insofar as practicable, forms shall be so constructed that the form marks will conform to the general lines of the structure. All sharp edges shall be chamfered with 3/4-inch by 3/4-inch triangular fillets.

Form clamps and ties with effective waterstops shall be used to accurately maintain the specified wall thickness. These ties shall be either of the threaded or snap-off type so that no metal will be left within 1-1/2-inches of the surface of the wall. Twisted-wire ties will not be permitted.

20.2.12 Openings

Pipe sleeves, inserts for pipe connections, anchors, and forms for pipe holes must be accurately placed and securely fastened to the forms in such a manner that the placing of concrete and stripping of forms will not alter their alignment or location. Openings may be formed at sleeve locations and sleeves placed and grouted with cement mortar containing 15 lbs. of EMBECO, or equal, per sack of cement, after wall concrete is placed. Rubber waterstops may be required at block-outs and shall be placed as directed by the District's Representative.

20.2.13 Joints

Construction joints shall be made only where shown on the Plans unless otherwise approved by the District's Representative. In case of emergency, construction joints shall

be placed as directed by the District's Representative. After the pour has been completed to the construction joint and the concrete has hardened, the entire surface of the joint shall be thoroughly cleaned of surface latency and clean aggregate shall be exposed by abrasive blast cleaning. Wire brushing, air and water jets may be used while the concrete is fresh, provided results equal to abrasive blast cleaning are obtained. Where subsequent concrete pour is a wall or other restricted formed member, approximately three (3) inches of grout shall be placed immediately before placing first lift of concrete. Concrete shall be placed over grout before the grout begins to set. Construction joints shall be keyed. Keyways shall be formed by beveled strips or boards placed at right angles to the direction of shear. Except where otherwise shown on the Plans or specified, keyways shall be at least 1-1/2 inches in depth over at least 25% of the area of the section. Waterstops may be required and shall be placed as directed by the District's Representative.

When it is necessary to make a joint because of an emergency, reinforcing steel shall be furnished and placed across the joint as directed by the District's Representative.

20.2.14 Surface Finishes

During the placing of concrete, care shall be taken in vibrating or otherwise consolidating concrete to ensure surfaces of even texture free from voids.

Immediately after the forms have been removed, all form bolts shall be removed to a minimum depth of 1-1/2 inches below the surface of the concrete. All holes and depressions caused by the removal or cutting back of such form bolts shall be cleaned and filled with cement grout. All rock pockets and honeycombed areas shall be repaired by chipping back to solid concrete and filling the resulting space in the same manner as specified for bolt holes. This work shall be done immediately following the removal of forms. If, in the judgment of the District's Representative, rock pockets are of such an extent or character as to affect the strength of the structure materially or to endanger the life of the steel reinforcement, he may declare the concrete unacceptable and require the removal and replacement of that portion of the structure.

Except for surfaces which are to be buried, all projections shall be removed and the surfaces shall be brushed with stiff wire brushes or otherwise finished until a uniform color has been obtained. The use of Carborundum stones may be required to remove surface imperfections. The object of these operations is to obtain smooth, even surfaces of uniform appearance, free from unsightly bulges, imperfections and depressions due to form marks.

All flat work shall be finished and worked from the poured slab and floated and troweled to a smooth, hard finish.

20.2.15 Reinforcement

Reinforcing bars shall be deformed billet-steel bars for concrete reinforcement, ASTM A615, Grade 40, unless otherwise provided. At the option of the Contractor, Grade 60 bars may be substituted for Grade 40, provided that the various grades of steel may not be used interchangeably in structures.

Bars shall not be bent or straightened in a manner that would injure the material. Hooks shall conform to the Manual of Standard Practice of the American Concrete Institute.

Main reinforcing bars shall not be spliced except as shown on the Plans. Splices at points of maximum stress shall be avoided. Where bars are spliced, they shall be lapped at least 30 bar diameters and wired together to provide a minimum distance of two (2) inches between the splice and the nearest adjacent bar or surface of the concrete. Splices shall be staggered at least 40 bar diameters.

Metal reinforcement shall be accurately placed as shown on the Plans and shall be securely held in position by wiring at intersections with No. 16 or larger wire and by using concrete spacers. The minimum spacing center to center of parallel bars shall be three times the diameter, but in no case shall the clear distance between bars be less than two (2) inches. All bars shall have a clear coverage 1-1/2 bar diameters but not less than 2-1/2 inches measured from the surface of the concrete to the outside of the bar. Metal supports may be used provided no portion of the support extends to within one inch on the surface on the concrete. Wooden supports shall not be used.

Wire mesh used for reinforcement shall be rolled flat before placing concrete and shall be supported and tied to prevent movement during concrete placement. Mesh shall conform to ASTM A185.

Reinforcement, at the time concrete is placed, shall be free from rust, scale and other coatings that would destroy or reduce bond strength.

20.2.16 Rubber Waterstops

Materials, fabrication, and splices shall conform to the article on Rubber Waterstops in Section 51 of the Standard Specifications of the California Department of Transportation (CALTRANS), latest revision. Stops shall be firmly supported during concrete placement to prevent dislocation and to insure that ends remain at right angles to the construction joints. All junctions shall be welded to provide a continuous watertight seal.

20.2.17 Grout

Grout shall contain Portland cement, sand, water and (for patching, anchoring, packing, or similar work) a non-shrinkage additive such as EMBECO. Where finish surface is not covered, grout shall be tinted by color of cement, aggregate, or additive as approved by the District's Representative so that surface matches adjacent concrete in appearance after both have cured. Ratio of cement to sand shall be 1 to 2 by volume unless otherwise shown or specified. The proportion of non-shrinkage additive shall be in accordance with the manufacturer's instructions. Grout shall be placed against thoroughly wetted concrete and shall be water-cured by providing a moist atmosphere for at least 3 days.

20.2.18 Curing Concrete

All newly-placed concrete shall be cured in accordance with the provisions of Section 90-7 of the State Standard Specifications. Any of the prescribed methods (water, curing compound, water-proof membrane, forms-in-place) may be used.

20.3 Construction

20.3.1 General

Concrete improvements shall conform to the provisions of Section 73 of the State Standard Specifications and these Standard Specifications.

20.3.2 Subgrade

The subgrade shall be constructed true to grade and cross-section, as shown on the Plans. It shall be thoroughly watered, rolled, pneumatically tamped or hand tamped to obtain 90 percent relative compaction, as measured by ASTM 1557. All soft and/or spongy material shall be removed to a depth of not less than six (6) inches below subgrade elevation for curbs, gutters, alley approaches and drive approaches, and three (3) inches below subgrade elevation for sidewalks and wheelchair ramps. The resulting space shall be filled with approved native soil, gravel, or sand, and shall be compacted to meet the requirements stated above.

20.3.3 Expansion Joints

Expansion joints for curb, gutter and sidewalk shall be constructed at a maximum spacing of 45 feet and at each drive approach and curb return.

20.4 Rock Pockets

Immediately upon stripping forms and prior to backfilling, all rock pockets or honeycombs shall be repaired to the satisfaction of RCWD. Repairs shall be made with Portland cement mortar conforming to the requirements of Section 51-1.135 of the State Standard Specifications.

20.5 Backfilling Improvements

After forms are removed, the area between the sidewalk and curb (if any) and the area behind the sidewalk shall be cleaned of all surplus concrete and other debris and the area shall be filled with clean native soil suitable for planting.

If curb and gutter is installed in an area where there is an existing paved street, Contractor shall repair all excavations made for such curb and gutter installation and shall backfill and pave the area between the old pavement and the new gutter with a like material. The edge of the existing pavement shall be cut to a true line (using a concrete saw if the existing pavement is asphalt concrete) and the excess paving material shall be removed from the project site. All paving work shall be done in accordance with the *Standard Specification for Materials and Requirements for Street Improvements*.

If more than two (2) inches of cut or fill are required behind the sidewalk (or behind the curb, if no sidewalk exists), Contractor shall construct a slope not steeper than 10:1 between the top of the sidewalk (or curb) and the adjacent property.

21 STANDARD SPECIFICATIONS FOR DUST CONTROL

21.1 General

This work shall consist of applying water and/or an approved dust palliative and taking other such actions as may be required for the alleviation or prevention of dust nuisance in and around the construction zone. Responsibility shall extend to adjacent streets where construction dirt may be spread either by wind or by construction equipment.

Such dust control shall be performed on a daily basis, including weekends and holidays. Job conditions may dictate application more than once per day. Contractor shall follow the direction of RCWD in increasing the intensity of his dust control effort if RCWD determines the need.

Contractor shall furnish all labor, materials, tools, and equipment necessary to maintain dust control herein specified. Failure to do so shall result in a "Stop Work Order" until such time that RCWD deems control has been re-established by the Contractor. RCWD reserves the right to order such work performed by its forces or by a third party selected by RCWD, and to collect all charges incurred thereby from the Contractor prior to issuance of certificate of completion or occupancy for the work.

All Dust Control work shall conform to the Fugitive Dust Control regulations published by the San Joaquin Valley Unified Air Pollution Control District.

21.2 Materials and Application

21.2.1 Materials

Materials shall be water and/or an approved dust palliative as designated below.

21.2.2 Dust Palliative

Dust Palliative binder shall be either miscible in water or be some form of material that is directly applied to the surface without mixing with water.

Binders that are miscible in water shall be either a resin emulsion, an SS-1 type asphaltic emulsion, materials composed essentially of lignin sulfonate, or any other binder that is miscible in water in the proportions provided below in *Application* is non-corrosive, and effective as a dust palliative.

Binders that are directly applied to the surface without mixing with water shall be products prepared from crude petroleum that are effective as dust palliative.

Resin emulsion shall be composed of 57%-63% of semi-liquid petroleum resin and the remainder water to which a suitable emulsifying agent has been added. The resin emulsion shall be readily miscible with water and when diluted with any water in the proportions of 1 (one) part emulsion to 10 (ten) parts water shall show no signs of breakdown or separation of the petroleum resin base. Resin emulsion which has been stored in closed containers at temperatures above freezing for a period up to 3 months shall not be used until tested and approved.

SS-1 type asphaltic emulsion shall conform to the State of California Department of Transportation Standard Specifications, Section 94, and latest edition.

21.2.3 Application

Binders that are miscible in water shall be mixed with additional water at the rate of 4-19 parts water to one (1) part binder. Mixing shall be accomplished by placing the binder and water in the spreading equipment simultaneously or by some other mixing method that will produce equivalent results, with approval by RCWD.

The resulting mixture shall be applied with a pressure-type water distributing truck equipped with a spray system or pressure-type asphalt distributors conforming to the State of California Department of Transportation Standard Specifications, Section 93-1.03, latest edition. The application rate shall be 0.2-0.8 gallons per square yard.

Binders that are applied directly to the surface without mixing with water shall be applied by equipment approved by RCWD. The binder shall be applied at a rate of 0.10-0.25 gallons per square yard.

22 STANDARD SPECIFICATIONS FOR MAINTENANCE OF TRAFFIC AND DETOURS

22.1 General

Traffic shall be maintained at those locations indicated and in conformance with the Plans, Encroachment Permit, these specifications and the Special Provisions.

The Contractor shall furnish, construct, maintain, and finally remove detours, road closures, lights, signs, barricades, fences, flares, miscellaneous traffic devices, flagmen, drainage facilities, reconstruct paving and such other items and services as are necessary to adequately safeguard the public from hazard and inconvenience. All such work shall be as provided in the specifications herein and as directed by the representative of the County of Madera and shall comply with the ordinances, directives, and regulations of authorities with jurisdiction over the public roads in which the construction takes place and over which detoured traffic is routed by the Contractor.

Prior to the start of construction operations, the Contractor shall notify the County of Madera and the Madera County Sheriff's and Fire Departments, giving the expected starting date, completion date and the names and telephone numbers of two responsible persons who may be contacted at any hour in the event of a condition requiring immediate correction.

22.2 Construction Signage

Construction signage used for controlling traffic and ensuring public convenience shall conform to the State of California, Department of Transportation *Manual of Warning Signs, Lights, and Devices for Use in Performance of Work Upon Highways,* latest revision.

All signs shall be illuminated or reflectorized if used during hours of darkness. All cones, pylons, barricades, or posts used in the diversion of traffic shall be provided with flashers or other satisfactory illumination if in place during hours of darkness.

All signage, barricading, and diversion of traffic shall be subject to the approval of the County of Madera, except in areas where encroachment permits issued by other agencies shall govern over these Standard Specifications. The Contractor shall maintain a 24-hour emergency service to remove, install, relocate, and maintain warning devices, and shall furnish to the authority names and telephone numbers of two persons responsible for this emergency service. In the event these persons do not promptly respond or the authority deems it necessary to call out other forces to accomplish emergency service, the Contractor will be held responsible for the cost of such emergency service.

22.3 Vehicular Traffic Control

Public traffic shall be permitted to pass through the construction area with as little inconvenience and delay as possible at all locations where approved alternate routes are not available.

No cross streets or intersecting streets shall be closed without approval of the County of Madera or authority with jurisdiction over the public roads in which the construction takes place and over which detoured traffic is routed by the Contractor.

22.4 Street Closure

Should it become necessary, in the Contractor's opinion, to close a particular street, Contractor shall submit a written request, to the County for consideration at least 72 hours prior to the time of such proposed closure. Contractor's request shall include the estimated duration of closure and provisions for traffic control and detours. If the County approves the closure plan, Contractor shall notify, in writing, the County and the Madera County Sheriff's and Fire Departments of the contemplated closure not less than 48 hours prior to such closure. Should Contractor fail to give the required notification, the closure will not be allowed until the required notification is given. Except as noted below, under no circumstances will such closure be allowed for a single period exceeding four hours, although the County may allow a road to be closed more than once over the course of the project.

For road closures requests exceeding the above-stated four hour maximum, the request to County must be made at least 10 days in advance of the contemplated closure and the County, the Sheriff, and the Fire Department must be notified at least 5 days prior to such closure.

22.5 Permanent Traffic Controls

All existing permanent traffic control signs, barricades, and devices shall remain in effective operation unless a substitute operation is arranged for and approved as a part of the vehicular traffic control plan above.

22.6 Pedestrian Traffic Control

A minimum of one 4-foot wide pedestrian walkway shall be maintained and safely delineated along each public street at all times during construction.

22.7 Access to Adjacent Properties

Prior to restricting normal access from public streets to adjacent properties, the Contractor shall notify each property owner or responsible person, informing him of the nature of the access restriction, the approximate duration of the restriction and the best alternate access route for that particular property.

Reasonable access, as determined by the County' Representative, from public streets to all adjacent properties shall be maintained at all times during the construction.

23 JACKING PIPE

23.1 General

This work shall consist of furnishing, boring, and jacking into place the type of pipe shown on the Plans or specified in the Special Provisions at locations and between the limits shown on the Plans or specified, and in accordance with these Specifications, the Standard Drawings and as directed by the Engineer.

Reinforced concrete pipe with rubber gasket joints, as a carrier pipe, as specified below, may be jacked into place directly without a jacked steel casing. All other carrier pipe must be installed within a jacked steel casing.

23.2 Materials

The casing pipe (or reinforced concrete pipe jacked without casing pipe) designated on the Plans shall be of the size and class (or strength designation) shown on the Plans or specified, except that the class of pipe designated has been determined for vertical loads only. Additional facilities, reinforcement, or strength of pipe required to withstand jacking pressure shall be determined and furnished by the Contractor.

Where reinforced concrete pipe, as a carrier pipe, is specified to be jacked into place directly without a jacked steel casing, said reinforced concrete pipe shall be furnished with rubber gasket joints, all in conformance with these Specifications. The reinforced concrete pipe shall be constructed such that no bells protrude from the outside periphery of the pipe. Sleeves for joints on reinforced concrete pipe shall be furnished and manufactured of galvanized steel, stainless steel, or fiberglass, sufficient in strength to withstand all loads, and which will maintain a water tight joint.

Steel casing pipe shall have a wall thickness not less than that shown on the Plans, and shall be butt welded of sheets conforming to ASTM A570 commercial grade or of plate conforming to ASTM A283. All field joints also shall be butt welded full circumference or by other means approved by the Engineer. Joints to be field welded shall be shop cut to ensure a true 90 degrees to the longitudinal axis of the pipe. Use of a jacking band to reinforce the end of the pipe receiving the jacking thrust will be required. It shall be the Contractor's responsibility to provide joints which are capable of resisting the jacking stresses without failure.

Carrier pipe to be installed within steel casing shall be as indicated on the Plans and/or Special Provisions. Composite blocks for supporting carrier pipe within steel casing shall be used. Blocks shall be v-cut to fit the contour of the pipe.

Concrete for plugs to be placed at ends of casing pipe as shown on the Standard Drawings shall be Class B, in conformance with Section 90 of the State Standard Specifications.

23.3 Excavation of Jacking and Receiving Pits

Excavation of jacking and receiving pits shall conform to the requirements of these Specifications, and shall be sheathed, shored, sloped or braced in accordance with the Safety Regulations of the State of California, Department of Industrial Relations, and Division of Industrial Safety. Reference is made to these Specifications.

Reference is also made to these Specifications, relative to the Contractor's responsibility for protecting workers and others from toxic or explosive gases.

23.4 Boring and Jacking

Pipe shall be jacked in conformity with the prescribed lines and grades obtained from the stakes set by the Engineer. Excavation for the pipe shall be accomplished by boring or by hand digging. Sluicing or jetting with water will not be permitted.

The excavated hole, whether bored or hand dug, shall not be more than 0.10 foot in diameter greater than the outside limits of the casing (or reinforced concrete pipe jacked without casing pipe). If the nature of the material is such that caving will likely occur and which may result in a greater space than above specified, a metal shield or jacking head shall be installed which extends a minimum of 18 inches ahead of the jacked casing or pipe. The metal shield shall cover a minimum of the upper 1/2 of the periphery of the jacked casing or pipe. Excavation shall not proceed beyond the shield.

Where ground conditions at the face of the jacking pit are such that sloughing or caving of ground is likely to occur at the face of the excavation upon commencement thereof, the face of the pit shall be made stable so that an excessive void is not carried with the face of the excavation for the length of the casing or pipe. This may be accomplished by solid sheathing at the portal of the jack, or excavating and backfilling the face of the pit with cohesive material.

Cavities or voids outside the limits specified above, regardless of cause, shall be backfilled with sand, soil, cement, or cement mortar as directed by the Engineer. The method by which backfill is to be performed shall be approved by the Engineer. All casing pipe 24 inches in diameter or larger, and all reinforced concrete pipe 24 inches in diameter or larger, shall be furnished with preinstalled fittings suitable for attachment to grout pumping equipment. Such grout connections, unless otherwise indicated on the Plans, shall be placed at 30 degrees, 120 degrees, 240 degrees and 330 degrees, measured clockwise, from vertical, around the circumference of the casing or pipe, and at intervals in each row, along the pipe, of no greater than 10 feet. Alternate bottom holes shall be staggered, and alternate top holes shall be staggered, so that one hole will occur at the top of every 5 feet and one hole will occur at the bottom of every 5 feet.

Immediately after completion of the jacking or boring operation, lean grout shall be injected through the grout connections in such a manner as to completely fill all voids outside the casing pipe or reinforced concrete pipe resulting from the jacking or boring operation. The lean grout shall consist of one part Portland cement to not more than 4 parts sand by volume, placed at low pressure. Grout pressure is to be controlled so as to avoid deformation of casing pipe and/or avoid movement of the surrounding soil. Sand for grout to be placed outside the casing shall be of such fineness that 100 percent will pass a No. 8 sieve and not less than 35 percent will pass a No. 50 sieve. After completion of grouting, the grout connections shall be closed with cast-iron threaded plugs.

In general, excavated material shall be removed from the casing or reinforced concrete pipe as jacking progresses and no accumulation of excavated material within the casing will be permitted. Should appreciable loss of ground occur in installations where the face

of the excavation is accessible, the voids shall be backpacked promptly to the extent practicable with an approved soil cement.

For jacked reinforced concrete pipe, if the annular space in the joints on the inside of the pipe exceeds one inch, the space shall be filled with cement mortar for the full periphery of the joint and finished smooth and flush with the interior walls of the pipe. Filling and finishing annular spaces shall be accomplished after the entire installation is completed for larger pipe.

Where carrier pipe is to be installed within a jacked casing, carrier pipe as shown on the Plans or indicated in the Special Provisions shall be installed within the casing pipe to the lines and grades shown on the Plans, and as indicated on the Standard Drawing pertaining thereto. The carrier pipe shall be supported on skids during the installation of the pipe. The skids shall be installed in such a manner as to relieve the couplings from all load and bearing. At the successful completion of the installation, concrete end seals (concrete plugs) shall be installed in accordance with the Standard Drawings. Care shall be taken during the placement of these seals that the pipe is not damaged, deflected or displaced.

23.5 Grade Tolerance

Reinforced concrete pipe jacked into place without steel casing shall not vary from theoretical alignment and grade at the time of completion of jacking by more than 0.50 foot in 100 feet for storm drain, and 0.10 foot in 100 feet for sanitary sewer.

Steel casing pipe of the minimum size and thickness specified on the Plans shall be installed in place to grades required to install the carrier pipe at the design grade. The Contractor's attention is called to the fact that extreme care will be required in placing the casing pipe so as to permit the construction of the carrier pipe to the lines and grades shown on the Plans. It shall be the Contractor's responsibility for selecting a size of casing, at or above the minimum specified, in order that the jacking may be done with a sufficient degree of accuracy to permit installation of the carrier pipe to the grade as shown on the Plans within the tolerances set forth in these Specifications for the particular carrier pipe installed. Any and all increased costs resulting from the Contractor's use of steel casing pipe with greater diameter or thickness than the minimum specified shall be borne solely by the Contractor. Variations from theoretical alignment and grade of the steel casing pipe at the time of completion of jacking shall not exceed one percent of the distance from the jacking point.

23.6 Backfill, Compaction and Restoration of Surfaces for Jacking and Receiving Pits

Jacking and receiving pits shall be backfilled and compacted, and the surface restored, in accordance with these Specifications.

23.7 Measurement

Measurement for reinforced concrete pipe with rubber gasket joints (without steel casing), jacked into place, shall be by the lineal foot of pipe jacked into place as shown on the Plans or as directed by the Engineer.

Measurement for steel casing pipe jacked into place shall be by the lineal foot of casing pipe jacked into place as shown on the Plans or as directed by the Engineer

Where carrier pipe is indicated on the Plans to be placed within a jacked casing pipe, carrier pipe will be measured by the lineal foot of pipe installed.

23.8 Payment

The unit price bid per lineal foot for reinforced concrete pipe with rubber gasket joints, jacked into place, shall include full compensation for furnishing all labor, materials, tools, equipment and incidentals and for doing all the work involved therein as shown on the Plans, as set forth in the Specification, and as directed by the Engineer. This shall include, but not be limited to, excavating, backfilling and compacting the jacking and receiving pits, boring and tunneling, furnishing and installing the pipe complete with grout fittings, furnishing and installing metal shields, grouting and backfill of voids, and all incidentals.

The unit price bid per lineal foot for steel casing, jacked into place, shall include full compensation for furnishing all labor, materials, tools, equipment and incidentals and for doing all the work involved therein as shown on the Plans, as set forth in these Specifications, and as directed by the Engineer. This shall include, but not be limited to, excavating, backfilling and compacting the jacking and receiving pits, boring and tunneling, furnishing and installing the casing complete with grout fittings, furnishing and installing metal shields, furnishing and installing skids and tie downs, grouting and backfill of voids, sealing ends of casing, and all other incidental work over and above that associated with the normal work of furnishing and installing the carrier pipe in a trench situation.

Carrier pipe to be placed in casing as shown on the Plans will be paid for as normal in-trench pipe as set forth in these Specifications for the particular type of pipe to be installed.

Index of Standards

RCWD Number	Description
D-1	Storm Sand Pipe Bedding and Trench Backfill
D-2	Storm Sand Pipe Bedding and Cement Slurry Trench Backfill
D-3	Storm Construction Joint Concrete Field Collar
D-4	Storm Type A Manhole
D-5	Storm Type B Manhole
D-6	Storm Cast Iron Manhole Frame & Cover
D-7	Precast Storm Type A Drainage Inlet
D-8	Cast In Place Storm Type A Drainage Inlet
D-9	Storm Type A Drainage Inlet 6" Curb and Gutter Topout
D-10	Storm Type A Drainage Inlet 4.5" Curb and Gutter Topout
D-11	Storm Type B Drainage Inlet with Slotted Manhole Grate
D-12	Storm Type C Drainage Inlet with Curb Face Opening
D-13	Storm Drainage Basin Metered Outlet Assembly and Overflow Weir
D-14	Storm Drainage Inlet Cutout Opening & Grate Detail
D-15	Storm Flared End Section Trash & Safety Rack
D-16	Storm Outfall Structure Type A
D-17	Storm Type A Outfall Modified Fence Cage
D-18	PP Storm Pipe Bedding and Trench Backfill
D-19	PP Storm Pipe Bedding and Cement Slurry Backfill
D-20	PP Storm Pipe Connection to Manholes
RW-1	Recycled Water Valve Box
RW-2	Recycled Water ID Sig 18"x12"
RW-3	Recycled Water ID Sig 18"x12"
S-1	Sewer Sand Pipe Bedding & Trench Backfill
S-2	Sewer Sand Pipe Bedding & Cement Backfill
S-3	4" Sewer Services
S-4	Sewer Service Connections
S-5	48", 60", 72" Sewer Manhole
S-6	Sewer Cast Iron Manhole Frame and Cover
S-7A	Drop Connections
S-7B	Stainless Steel Adjustable Clamping Brackets
S-8	4", 6", 8" Sewer Cleanout
S-9	Sewer Sand and Grease Interceptor
S-10	Sewer Pipe in Jacked Steel Casing
S-11	Metering Sewer Manhole
S-12	Manhole Pipe Connection
ST-1	Local Street Utility Locations
ST-2	Two Lane Collector & Industrial Street Utility Locations
ST-3	Four Lane Major Street Utility Locations
ST-4	Trench Resurfacing
W-1	Water Sand Pipe Bedding & Trench Backfill
W-2	Water Sand Pipe Bedding & Cement Sand Slurry Backfill
W-3	PVC Pipe Tee Restraints
W-4	PVC Bend Restraints

Index of Standards

RCWD Number	Description
W-5	PVC Pipe Restraints
W-6	Ductile Iron Tee Restraints
W-7	Ductile Iron Bend Restraints
W-8	Ductile Iron Pipe Restraints
W-9	Water Valve
W-10	Fire Hydrant Installation
W-11	Water Sample Station Installation
W-12	1" Service Connection & Meter Box Installation
W-13	1.5" Service Connection & Meter Box Installation
W-14	2" Service Connection & Meter Box Installation
W-15	Typical Fire Hydrant Marker Locations
W-16	Blow-Off Assembly In Line Installation
W-17	Blow-Off Assembly End of Line Installation
W-18	Temporary Blow off Assembly with Restrained Joint
W-19	1", 1.5", 2" Reduced Pressure Principle Backflow Assembly Installation
W-20	Typical Enclosure for Backflow Prevention Devices
W-21	4" & Larger Standard Meter - Backflow Installation
W-22	Fire-Line Installation
W-23	Fire-Line Installation without F.D.C.
W-24	10" Ag Turnout
W-25	Pipe Support
W-26	1" & 2" Automatic Air Release and Vacuum Valve (ARV)
W-27	Installation Requirements for an Approved Air Gap Separation
W-28	Approved Portable Water Transport Backflow Protection
W-29	Guard Post Details
W-30	Temporary RP Principle Backflow Assembly Installation
W-31	Monitoring Well Manhole Construction Detail
W-32	Water Well Destruction
W-33	Utility Marker
W-34	Water Pipe in Jacked Steel Casing
W-35	Sewer and Water Main Parallel Construction Separation
W-36	Sewer and Water Main Crossing Construction Separation
W-37	Water Pipe Hot Tap Sheet
W-38	Temporary Blow off Assembly with Concrete Thrust Restraint
W-39	Thrust Blocks

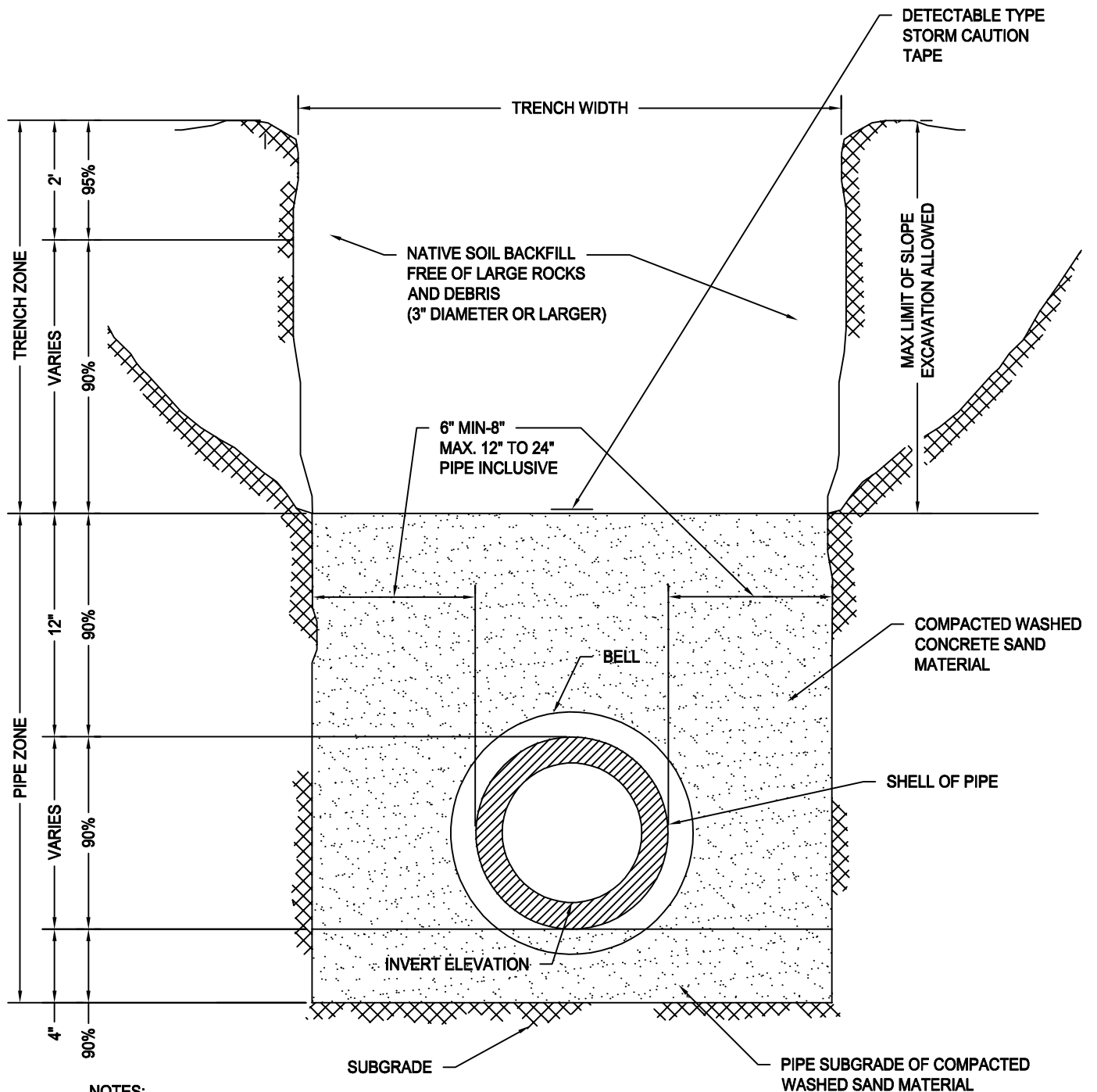

NOTES:

1. APPLICABLE FOR INSTALLATION WITH 3' OR GREATER MINIMUM COVER.
2. FOR COVER LESS THAN 3' SEE STANDARD DETAIL D-2
3. GRAVITY STORM PIPE AND FITTINGS SHALL BE RGRCP, C76 WITH INTEGRAL RUBBER GASKET JOINTS.
4. PIPE ZONE MATERIAL SHALL BE WASHED CONCRETE SAND FREE OF SILT AND ORGANIC MATERIAL. PIPE ZONE SHALL INITIALLY BE FILLED TO SPRINGLINE OF PIPE, WATERED, AND HAUNCHES COMPACTED WITH A WACKER TYPE COMPACTOR 4" WIDE X 12" LONG SHOE PLATE.
5. COMPACTION TESTING OF ALL TRENCHES SHALL BE REQUIRED AS SPECIFIED IN STANDARD SPECIFICATIONS AND AS DIRECTED BY THE DISTRICT ENGINEER & OWNER.
6. SPECIFIED COMPACTION REQUIREMENTS ARE DISTRICT MINIMUMS AND IN THE EVENT OF CONFLICTS, THE MORE RESTRICTIVE REQUIREMENT SHALL PREVAIL.
7. TRENCH PATCH REQUIREMENTS ARE SPECIFIED AT STANDARD DETAIL ST-4.
8. STORM PIPE SUBJECT TO STORM WATER RETENTION DURING STORM OR OTHER RELATED EVENTS SHALL REQUIRE HYDROSTATIC TESTING PER STANDARD SPECIFICATIONS.



**ROOT CREEK WATER DISTRICT
STANDARD DETAIL**

PREPARED BY: STEPHEN GRISEZ
Stephen Grisez
NICK BRUNO, RCWD PRESIDENT

**STORM SAND PIPE BEDDING & TRENCH
BACKFILL**

SCALE: NOT TO SCALE

DATE ADOPTED: 4-12-2021

D-1

SHEET 1 OF 17

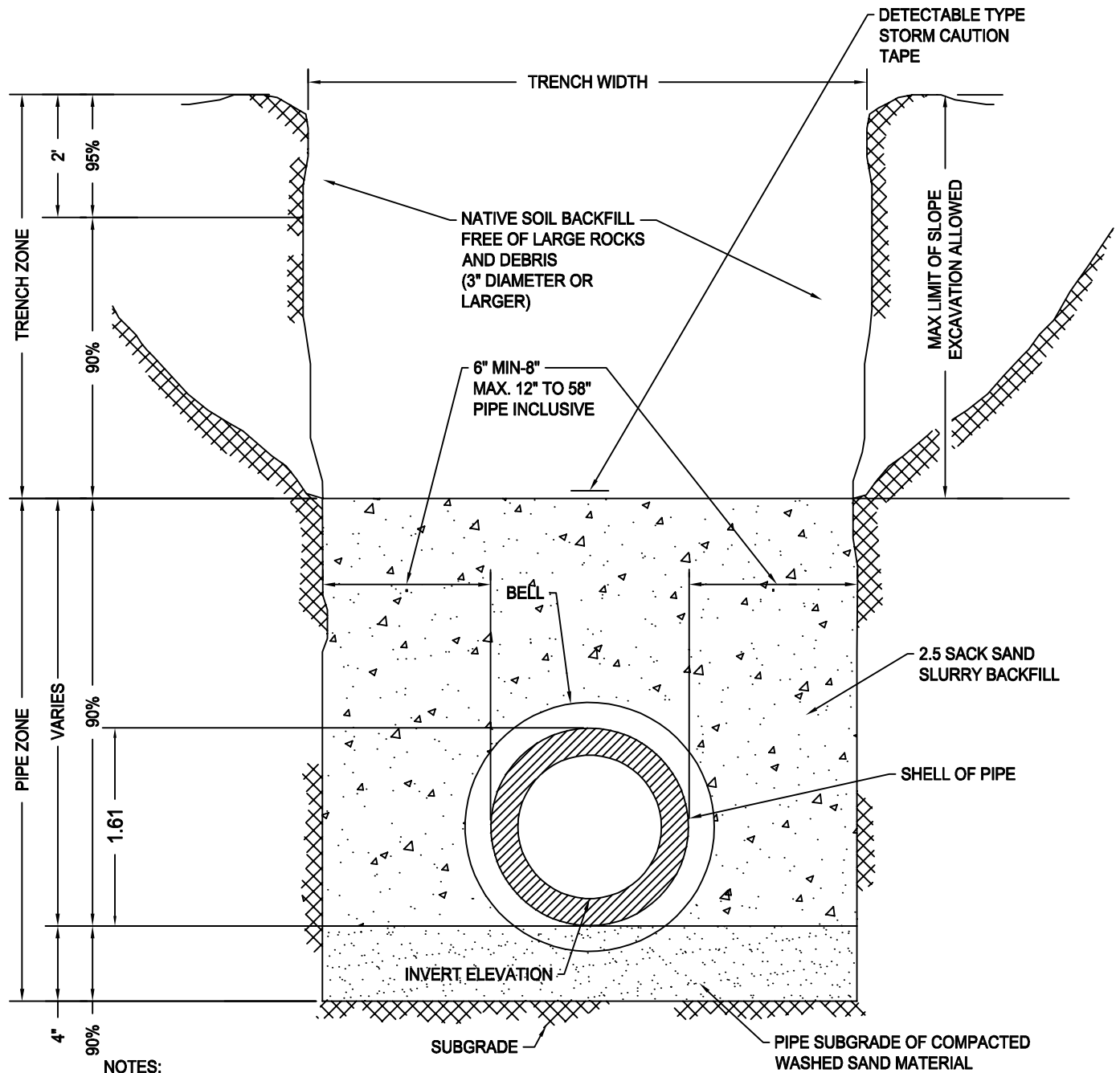

NOTES:

1. APPLICABLE FOR INSTALLATION WITH LESS THAN 3' MINIMUM COVER.
2. GRAVITY STORM PIPE AND FITTINGS SHALL BE RGRCP, PACKER HEAD, C76 WITH INTEGRAL RUBBER GASKET JOINTS.
3. BEDDING MATERIAL SHALL BE WASHED CONCRETE SAND FREE OF SILT AND ORGANIC MATERIAL.
4. PIPE ZONE MATERIAL SHALL BE 2.5 SACK CEMENT SAND SLURRY.
5. COMPACTION TESTING OF ALL TRENCHES SHALL BE REQUIRED AS SPECIFIED IN STANDARD SPECIFICATIONS AND AS DIRECTED BY THE DISTRICT ENGINEER & OWNER.
6. SPECIFIED COMPACTION REQUIREMENTS ARE DISTRICT MINIMUMS AND IN THE EVENT OF CONFLICTS, THE MORE RESTRICTIVE REQUIREMENT SHALL PREVAIL.
7. TRENCH PATCH REQUIREMENTS ARE SPECIFIED AT STANDARD DETAIL ST-4.
8. STORM PIPE SUBJECT TO STORM WATER RETENTION DURING STORM OR OTHER RELATED EVENTS SHALL REQUIRE HYDROSTATIC TESTING PER STANDARD SPECIFICATIONS.
9. THIS DETAIL SHALL FULLY COMPLY WITH STANDARDS W-35 AND W-36 AND IS NOT INTENDED TO BE USED AS A MITIGATION MEASURE.
10. THIS DETAIL MAY ONLY BE USED WHEN WRITTEN APPROVAL IS GRANTED BY THE DISTRICT ENGINEER.



**ROOT CREEK WATER DISTRICT
STANDARD DETAIL**

PREPARED BY: STEPHEN GRISEZ
Stephen Grisez
NICK BRUNO, RCWD PRESIDENT

**STORM SAND PIPE BEDDING & CEMENT
SAND SLURRY TRENCH BACKFILL**

SCALE: NOT TO SCALE

DATE ADOPTED: 8-12-2019

D-2

SHEET 2 OF 17

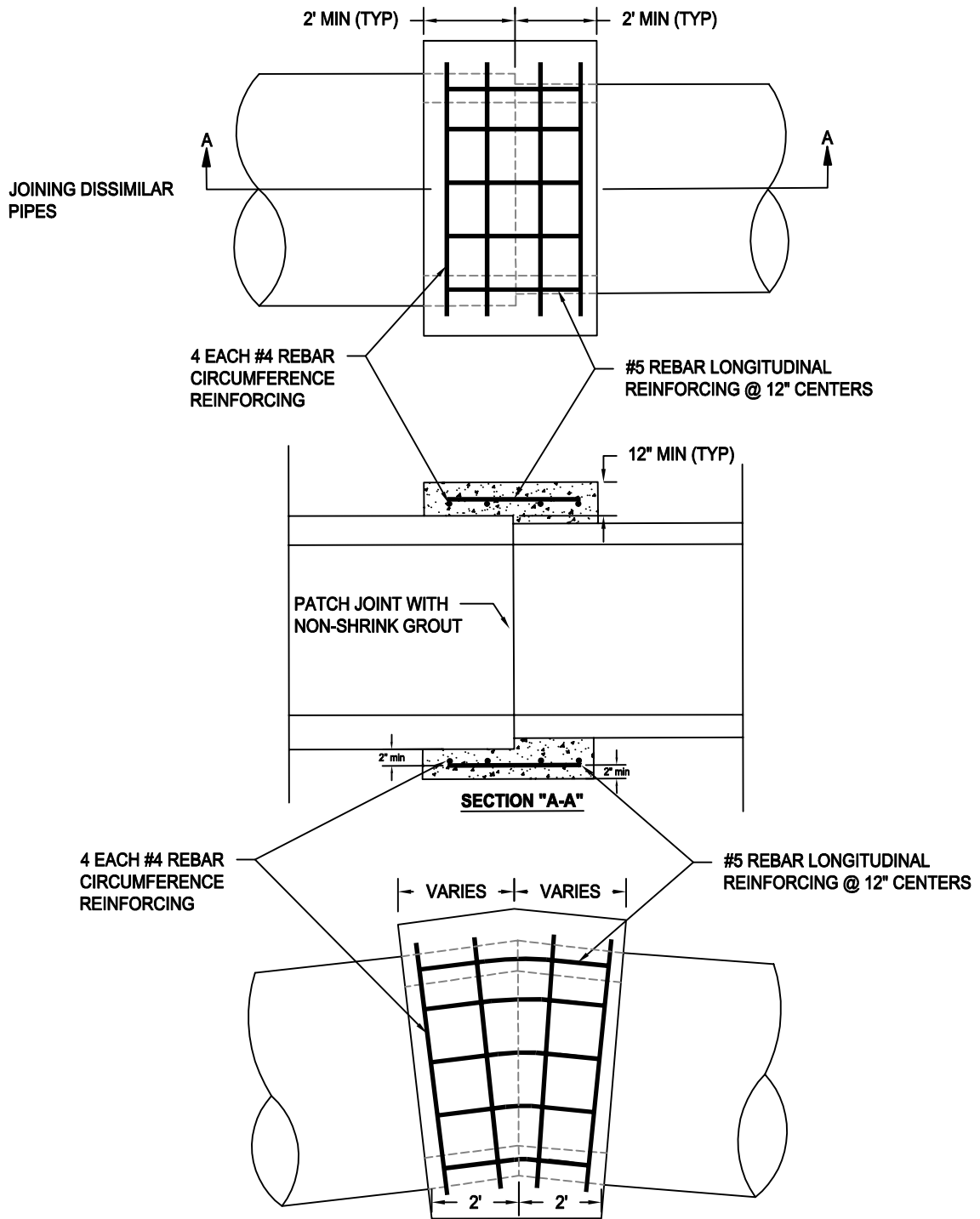

NOTES:

1. CONCRETE COLLAR SHALL BE 6 SACK CONCRETE & 3,000 PSI MINIMUM.
2. INSIDE OF COLLAR SHALL MATCH PIPE DIAMETER, SMOOTH STEEL TROWEL FINISH.
3. ALLOW CONCRETE TO HARDEN BEFORE BACKFILLING.
4. WHEN FORMING ANGLES ENGINEER MAY REQUIRE CHAMFERING OF PIPE ENDS.



**ROOT CREEK WATER DISTRICT
STANDARD DETAIL**

PREPARED BY: *Stephen Grisez*
STEPHEN GRISEZ
NICK BRUNO, RCWD PRESIDENT

**STORM CONSTRUCTION JOINT
CONCRETE FIELD COLLAR**

SCALE: NOT TO SCALE

DATE ADOPTED: 8-12-2019

D-3

SHEET 3 OF 17

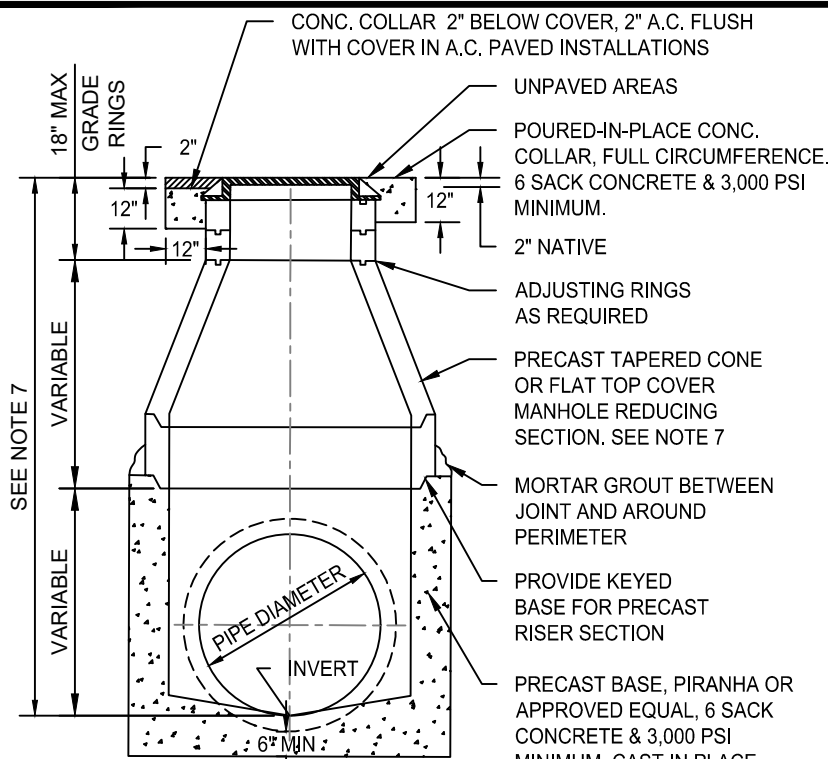

SECTION "A"

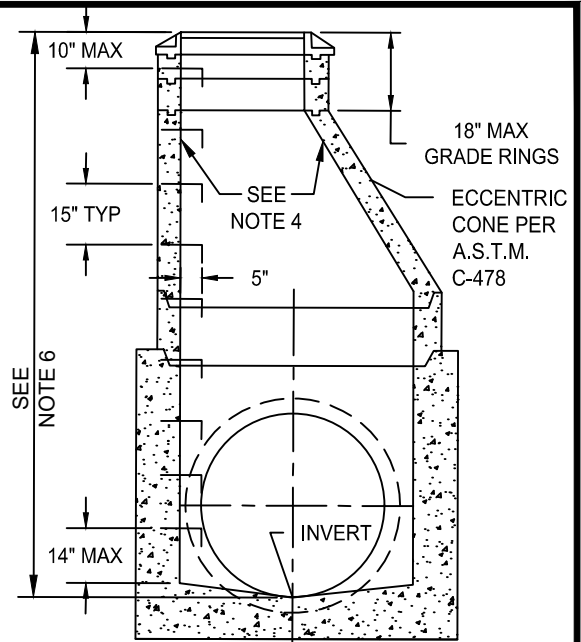

SECTION "A"

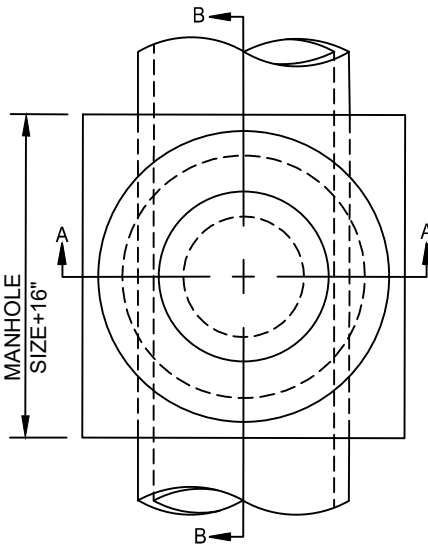

PLAN

UNPAVED AREAS
POURED-IN-PLACE CONC. COLLAR, FULL CIRCUMFERENCE. 6 SACK CONCRETE & 3,000 PSI MINIMUM.
2" NATIVE
ADJUSTING RINGS AS REQUIRED
PRECAST TAPERED CONE OR FLAT TOP COVER MANHOLE REDUCING SECTION. SEE NOTE 7
MORTAR GROUT BETWEEN JOINT AND AROUND PERIMETER
PROVIDE KEYED BASE FOR PRECAST RISER SECTION
PRECAST BASE, PIRANHA OR APPROVED EQUAL, 6 SACK CONCRETE & 3,000 PSI MINIMUM. CAST IN PLACE APPROVED ON A CASE BY BASIS BY DISTRICT ENGINEER

JOINTS REQUIRE RUBBER GASKETS, RAMNECK OR APPROVED EQUAL. FINISH INTERIOR JOINTS WITH MORTAR BANDING AFTER BACKFILL & COMPACTION IS COMPLETE

MANHOLE FRAME AND COVER SEE DWG. NO. D-6
INSTALLATIONS IN NON PAVEMENT AREAS UNLESS OTHERWISE SPECIFIED, SET FRAME 2" ABOVE FINISH GRADE. COLLAR SHALL BE FORMED (CIRCULAR FORM). EXPOSED EDGE SHALL RECEIVE A 1/2" RADIUS AND SURFACE SHALL RECEIVE A NON-SLIP MEDIUM BROOM FINISH.
POURED IN PLACE, 6 SACK CONCRETE & 3,000 PSI MIN COLLAR, FULL CIRCUMFERENCE
PRECAST TAPERED CONCENTRIC OR ECCENTRIC REDUCERS AS REQUIRED. PIRANHA OR APPROVED EQUAL.

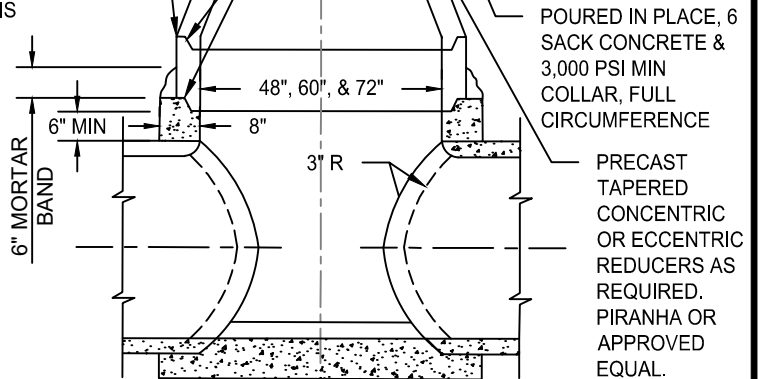

SECTION "B"

NOTES:

1. PRECAST PIPE, ADJUSTING RINGS AND TAPERED OR FLAT TOP SECTIONS SHALL BE CONSTRUCTED IN ACCORDANCE WITH A.S.T.M. C-478, USING TYPE II CEMENT.
2. THE JOINT BETWEEN THE PRECAST RISER AND POURED-IN-PLACE CONCRETE RISER AND BASE, AND ALL JOINTS BETWEEN PRECAST SECTIONS INCLUDING GRADE RINGS SHALL BE MORTARED.
3. PROVIDE 6" MORTAR BAND AROUND EXTERIOR OF RISER-TO-BASE JOINT.
4. INTERIOR OF THE MANHOLE SHALL HAVE A SMOOTH TROWELED SURFACE.
5. MANHOLE SIZE TO BE MINIMUM 12" LARGER THAN LARGEST PIPE ENTERING MANHOLE. MINIMUM SIZE TO BE 48".
6. ALL MANHOLES GREATER THAN 7' ULTIMATE DEPTH REQUIRE ECCENTRIC CONES AND PVC STEPS.
7. ALL MANHOLES GREATER THAN 20' ULTIMATE DEPTH SHALL BE INCREASED MINIMUM 60" DIAMETER.
8. IF THE REQUIRED STRUCTURE EXCEEDS THE LARGEST DIMENSION SPECIFIED BY THE ROOT CREEK WATER DISTRICT STANDARD DETAIL, THE FRESNO METROPOLITAN FLOOD CONTROL DISTRICT (FMFCD) STANDARD DETAILS MAY BE USED TO ACCOMMODATE THE LARGER SIZES. FOR STRUCTURES LARGER THAN THOSE COVERED BY RCWD STANDARDS, THE MANHOLE BASE MAY BE CAST-IN-PLACE PER FMFCD DETAILS, SUBJECT TO RCWD APPROVAL.



**ROOT CREEK WATER DISTRICT
STANDARD DETAIL**

**48 IN, 60 IN & 72 IN TYPE A
STORM MANHOLE**

PREPARED BY: STEPHEN GRISEZ

SCALE: NOT TO SCALE

D-4

NICK BRUNO, RCWD PRESIDENT

DATE ADOPTED: 12-8-2025

SHEET 4 OF 17

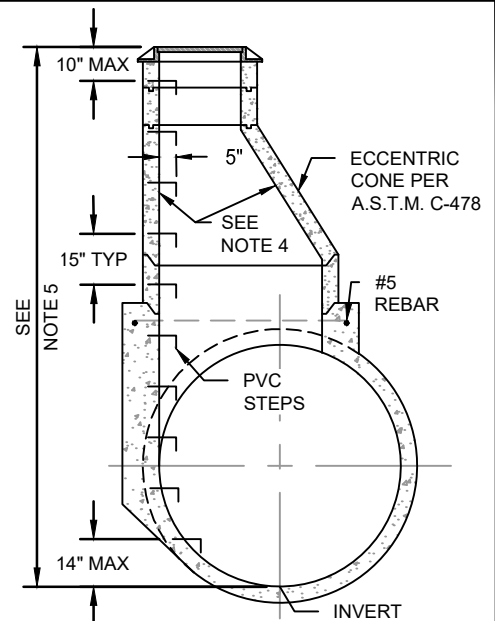
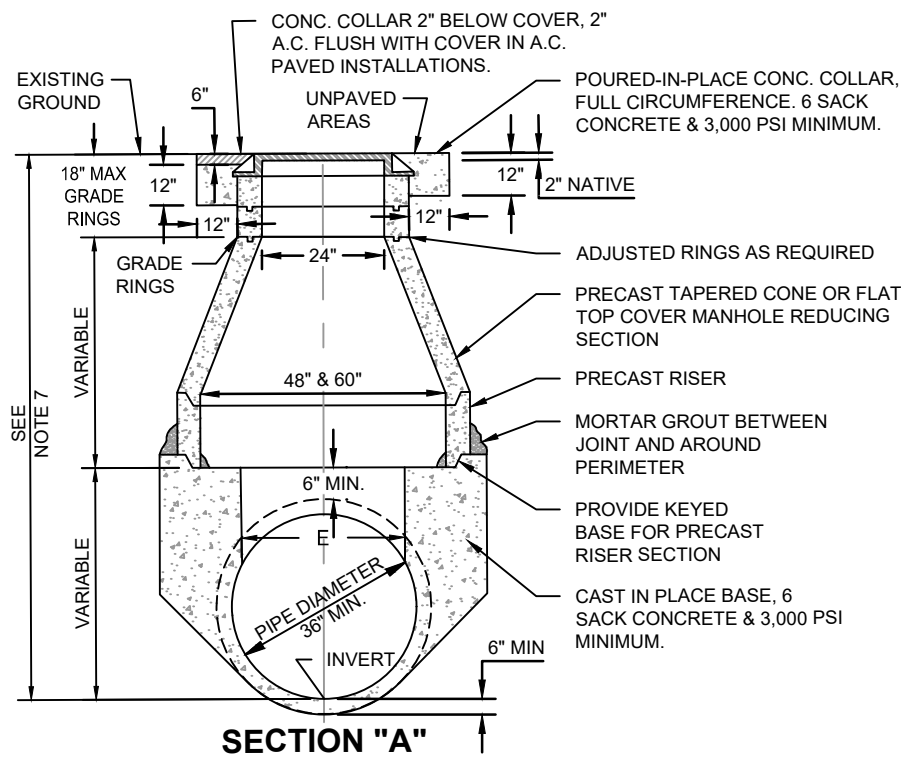

SECTION "A"

DIMENSIONS				
PIPE DIA.	IN	36	42	48 54 AND GREATER
B	IN	14	11	8 EQUALS PIPE WALL THICKNESS
E	IN	32	38	44 48

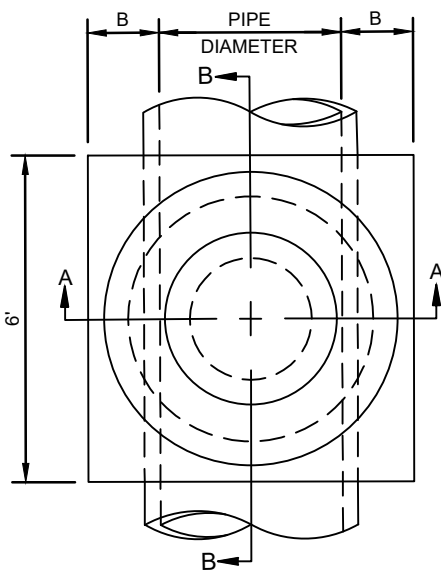

PLAN

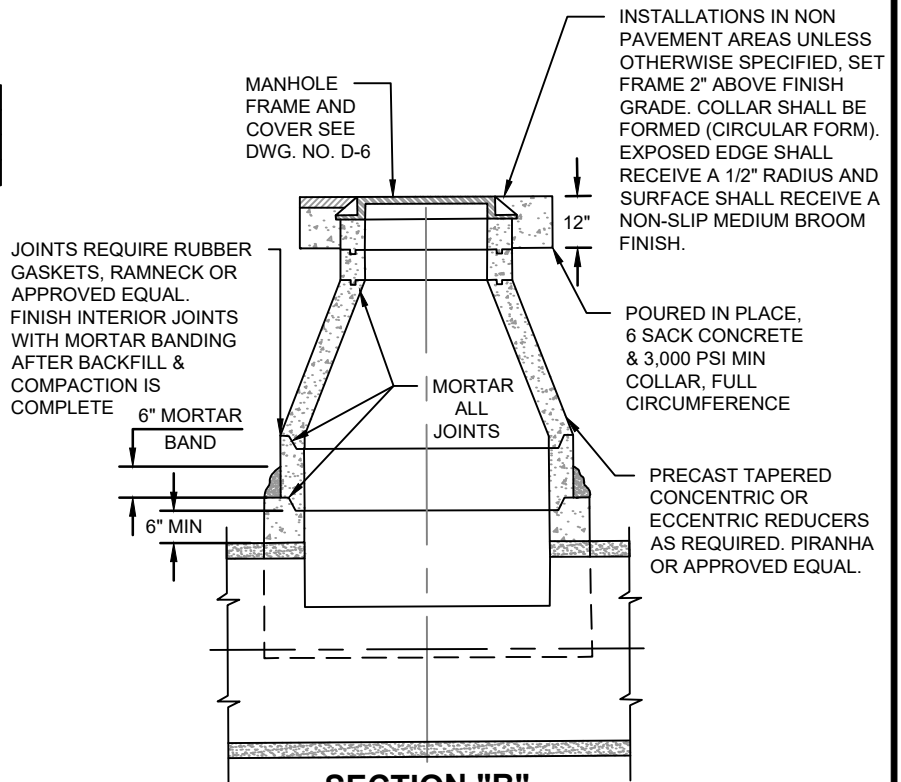

SECTION "B"

NOTES:

1. PRECAST PIPE, ADJUSTING RINGS AND TAPERED OR FLAT TOP SECTIONS SHALL BE CONSTRUCTED IN ACCORDANCE WITH A.S.T.M. C-478, USING TYPE II CEMENT.
2. THE JOINT BETWEEN THE PRECAST RISER AND POURED-IN-PLACE CONCRETE RISER AND BASE, AND ALL JOINTS BETWEEN PRECAST SECTIONS INCLUDING GRADE RINGS SHALL BE MORTARED.
3. PROVIDE 6" MORTAR BAND AROUND EXTERIOR OF RISER-TO-BASE JOINT.
4. INTERIOR OF THE MANHOLE SHALL HAVE A SMOOTH TROWELED SURFACE.
5. FOR REINFORCED CONCRETE PIPES, CUT AND BEND STEEL REINFORCEMENT INTO CAST-IN-PLACE MANHOLE BASE.
6. ALL MANHOLES GREATER THAN 7' ULTIMATE DEPTH REQUIRE ECCENTRIC CONES AND PVC STEPS PER MANUFACTURER SPECIFICATIONS.
7. ALL MANHOLES GREATER THAN 20' ULTIMATE DEPTH SHALL BE INCREASED TO A MINIMUM OF 60" DIAMETER.
8. IF THE REQUIRED STRUCTURE EXCEEDS THE LARGEST DIMENSIONS SPECIFIED BY THE ROOT CREEK WATER DISTRICT STANDARD DETAIL, THE FRESNO METROPOLITAN FLOOD CONTROL DISTRICT (FMFCD) STANDARD DETAILS MAY BE USED TO ACCOMMODATE THE LARGER SIZES AND SUBJECT TO RCWD APPROVAL.



**ROOT CREEK WATER DISTRICT
STANDARD DETAIL**

PREPARED BY: STEPHEN GRISEZ
NICK BRUNO, RCWD PRESIDENT

48 IN & 60 IN TYPE B STORM MANHOLE

SCALE: NOT TO SCALE

DATE ADOPTED: 12-8-2025

D-5

SHEET 5 OF 17

NOTES:

1. ALL MATING CONTACT SURFACES ON ON THE FRAME AND COVER SHALL BE MACHINED.
2. IDENTIFY ALL MANHOLE COVERS "STORM" OR "STORM SYSTEM"
3. FRAME & COVER SHALL BE FULL H-20 RATED.

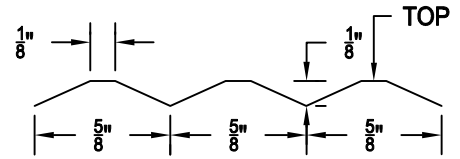

DETAIL OF WAFFLE PATTERN

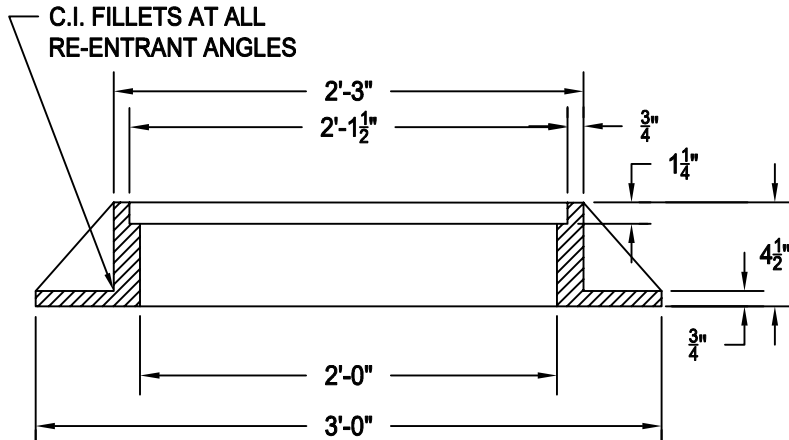

CROSS SECTION

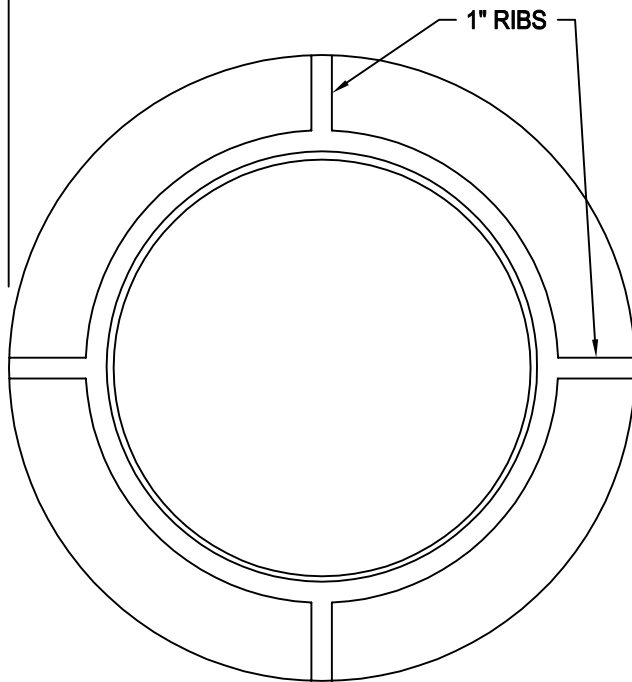

**PLAN
MANHOLE FRAME**

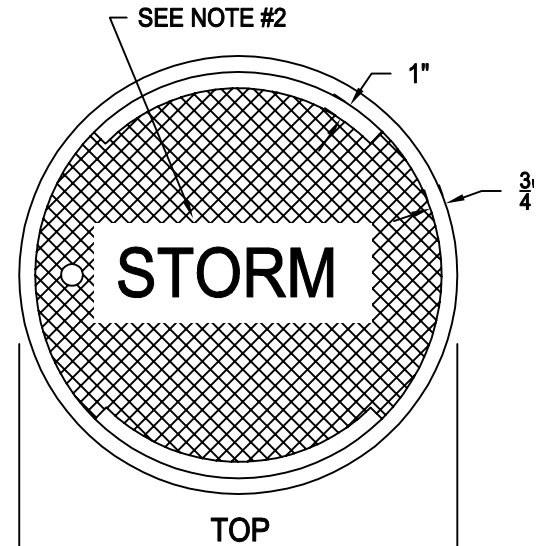

TOP

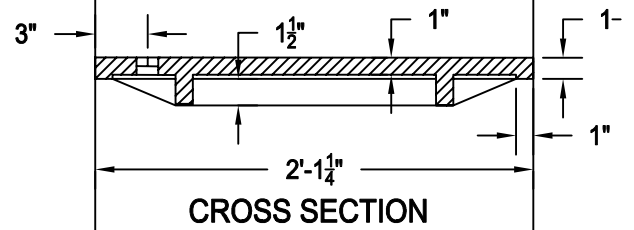

CROSS SECTION

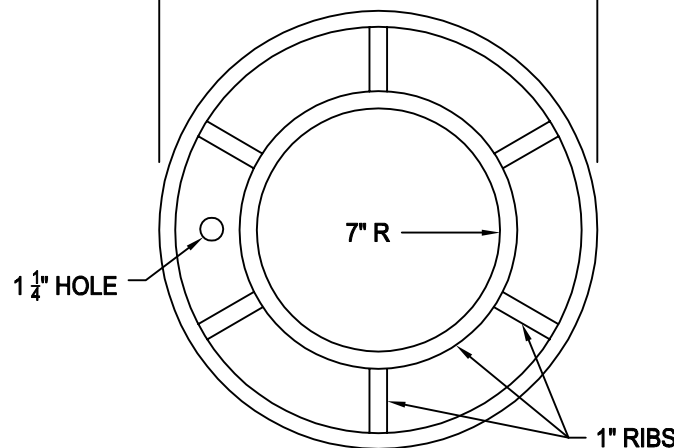

**BOTTOM
MANHOLE COVER**



**ROOT CREEK WATER DISTRICT
STANDARD DETAIL**

PREPARED BY: *Stephen Grisez*
STEPHEN GRISEZ
NICK BRUNO, RCWD PRESIDENT

**STORM CASR IRON MANHOLE
FRAME AND COVER**

SCALE: NOT TO SCALE

DATE ADOPTED: 8-12-2019

D-6

SHEET 6 OF 17

CALTRANS TYPE 24 FRAME, GRATE, & GO HEADER WITH SAFETY BAR

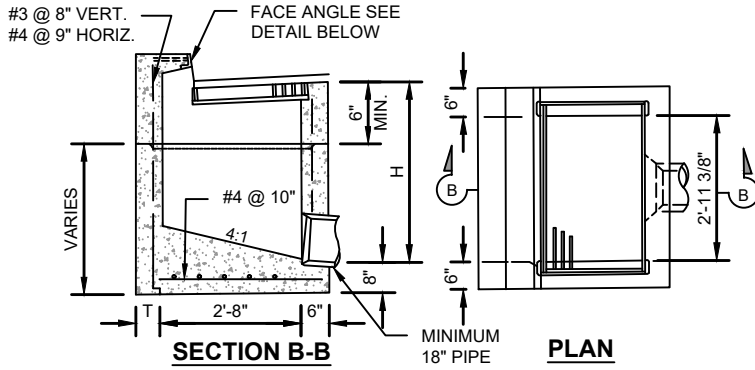

TYPE GO

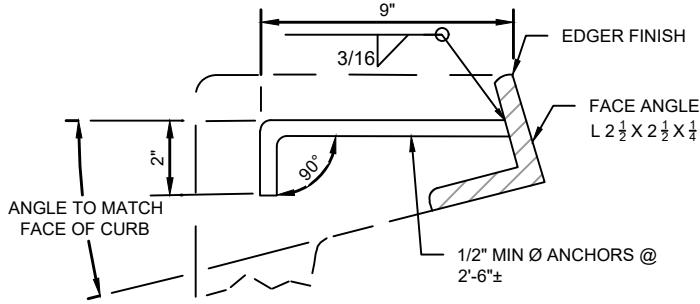

FACE ANGLE ANCHOR

NOTES:

1. CONFORMS TO CALTRANS STD. PLAN D77B
2. MATERIAL FOR BEARING AND CROSS BARS SHALL CONFORM TO ASTM A-36.
3. MATERIAL IS AVAILABLE AS BARE METAL OR GALVANIZED. GALVANIZING SHALL BE HOT-DIPPED AFTER FABRICATION PER ASTM A-123.
4. GRATE IS DESIGNED FOR 16 KIP WHEEL LOAD (H-20)

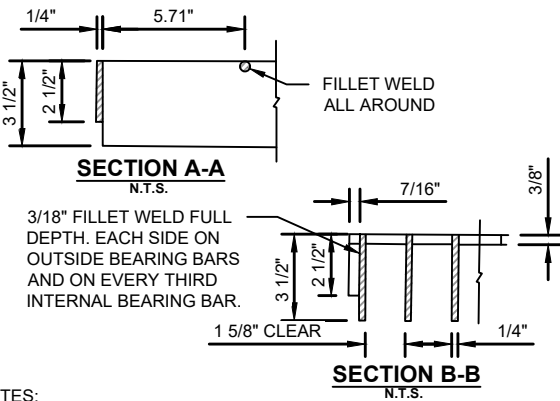

SECTION B-B
N.T.S.

NOTES:

1. WALL REINFORCEMENT MUST BE PLACED AT THE CENTER OF WALL WITH HORIZONTAL BARS PLACED ON THE EXTERIOR FACE. BOTTOM SLAB COVER MUST BE 3" CLEARANCE ON THE INTERIOR FACE.
2. STEPS - NONE REQUIRED WHERE "H" IS LESS THAN 7' WHERE "H" IS 7' OR MORE, INSTALL STEPS WITH LOWEST RUNG 1'-0" ABOVE THE FLOOR AND HIGHEST RUNG NOT MORE THAN 6" BELOW TOP OF INLET. THE DISTANCE BETWEEN STEPS SHALL NOT EXCEED 1'-0" AND SHALL BE UNIFORM THROUGHOUT THE LENGTH OF THE WALL. PLACE STEPS IN THE WALL WITHOUT AN OPENING. STEPS SHALL COMPLY WITH STATE INDUSTRIAL SAFETY REQUIREMENTS.
3. PIPE(S) CAN BE PLACED IN ANY WALL.
4. CURB SECTION SHALL MATCH ADJACENT CURB.
5. BASIN FLOORS SHALL HAVE STEEL TROWEL FINISH AND SHALL SLOPE TOWARD THE OUTLET PIPE AS SHOWN.
6. STANDARD SQUARE, HEXAGON, ROUND OR EQUIVALENT HEADED ANCHORS MAY BE SUBSTITUTED FOR THE RIGHT ANGLE HOOKS ON THE ANCHORS AS SHOWN ON THIS PLAN.
7. PRECAST INLETS ALL CONNECTIONS SHALL BE SEALED WITH RAMNECK OR APPROVED EQUAL JOINT SEALANT AND INSIDE SHALL RECEIVE A MORTARED FINISH.
8. CAL TRANS TYPE 24 FRAME:
 - MATERIAL MAY CONFORM TO ASTM A-36
 - FRAME SHALL BE GALVANIZED AFTER FABRICATION PER ASTM A-123
 - FRAME SHALL MEET H-20 WHEEL LOADING
9. PRECAST STORM INLET TYPE "A" DRAINAGE INLET FOR $H \leq 8'$, ASSEMBLY SHALL BE PIRANHA PIPE & PRECAST OR APPROVED EQUAL. FOR $H \geq 8'$ CONTACT DISTRICT ENGINEER
10. MINIMUM 18" PIPE FROM INLET TO STORM DRAIN MANHOLE

CALTRANS TYPE 24 FRAME

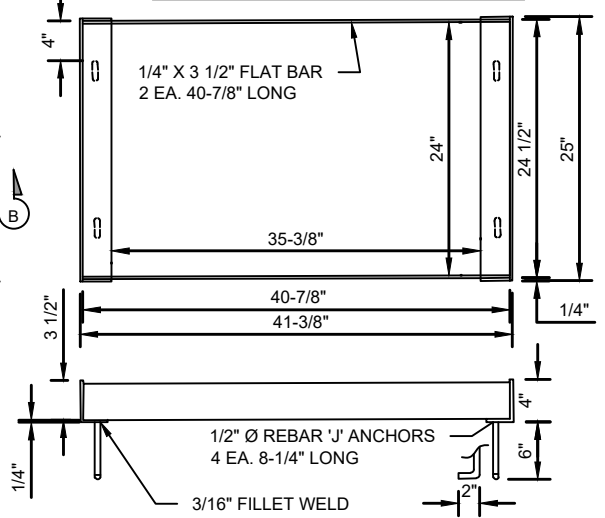

WEIGHT: 45 LBS.

ALL GRATES SHALL BE PEDESTRIAN AND BICYCLE RATED TYPE

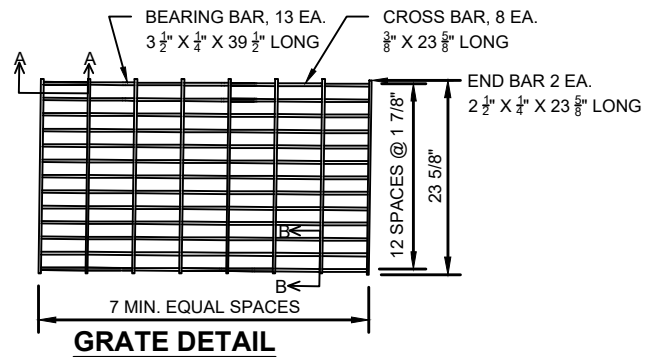

GRATE DETAIL

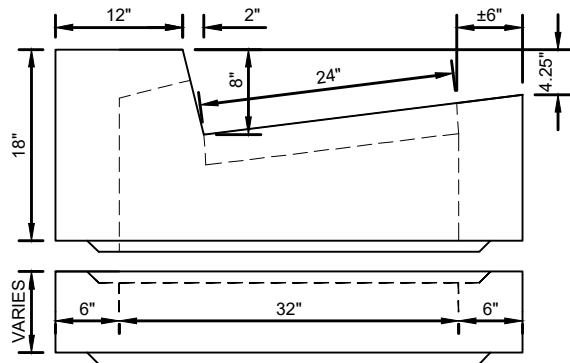

**ROOT CREEK WATER DISTRICT
STANDARD DETAIL**

PREPARED BY: STEPHEN GRISEZ
NICK BRUNO, RCWD PRESIDENT

**PRECAST STORM TYPE A
DRAINAGE INLET**

SCALE: NOT TO SCALE

DATE ADOPTED: 11-15-2021

D-7

SHEET 7 OF 17

**CALTRANS TYPE 24 FRAME, GRATE, & GO
HEADER WITH SAFETY BAR**

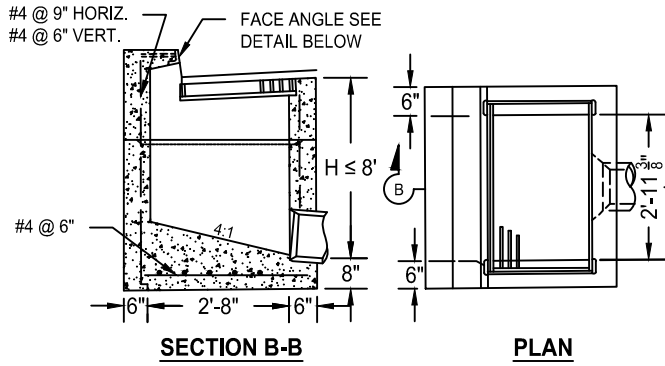

SECTION B-B

PLAN

TYPE GO

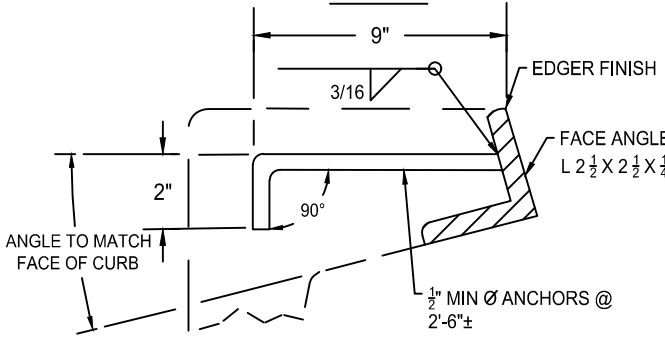

FACE ANGLE ANCHOR

NOTES:

1. CONFORMS TO CALTRANS STD. PLAN D77B
2. MATERIAL FOR BEARING AND CROSS BARS SHALL CONFORM TO ASTM A-36.
3. MATERIAL IS AVAILABLE AS BARE METAL OR GALVANIZED. GALVANIZING SHALL BE HOT-DIPPED AFTER FABRICATION PER ASTM A-123.
4. GRATE IS DESIGNED FOR 16 KIP WHEEL LOAD (H-20)

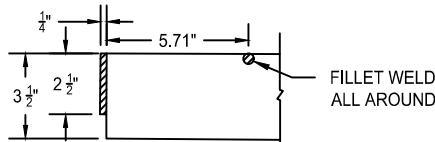

SECTION A-A
N.T.S.

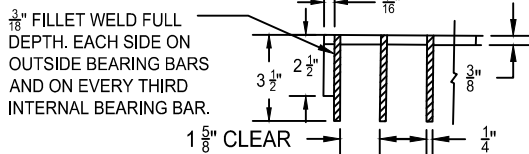

SECTION B-B
N.T.S.

NOTES:

1. WALL REINFORCEMENT MUST BE PLACED AT THE CENTER OF WALL WITH HORIZONTAL BARS PLACED ON THE EXTERIOR FACE. BOTTOM SLAB COVER MUST BE 3" CLEARANCE WITH INTERIOR FACE.
2. STEPS - NONE REQUIRED WHERE "H" IS LESS THAN 7' WHERE "H" IS 7' OR MORE, INSTALL STEPS WITH LOWEST RUNG 1'-0" ABOVE THE FLOOR AND HIGHEST RUNG NOT MORE THAN 6" BELOW TOP OF INLET. THE DISTANCE BETWEEN STEPS SHALL NOT EXCEED 1'-0" AND SHALL BE UNIFORM THROUGHOUT THE LENGTH OF THE WALL. PLACE STEPS IN THE WALL WITHOUT AN OPENING. STEPS SHALL COMPLY WITH STATE INDUSTRIAL SAFETY REQUIREMENTS.
3. PIPE(S) CAN BE PLACED IN ANY WALL.
4. CURB SECTION SHALL MATCH ADJACENT CURB.
5. BASIN FLOORS SHALL HAVE STEEL TROWEL FINISH AND SHALL SLOPE TOWARD THE OUTLET PIPE AS SHOWN.
6. STANDARD SQUARE, HEXAGON, ROUND OR EQUIVALENT HEADED ANCHORS MAY BE SUBSTITUTED FOR THE RIGHT ANGLE HOOKS ON THE ANCHORS AS SHOWN ON THIS PLAN.
7. PRECAST INLETS ALL CONNECTIONS SHALL BE SEALED WITH RAMNECK OR APPROVED EQUAL JOINT SEALANT AND INSIDE SHALL RECEIVE A MORTARED FINISH.
8. CAL TRANS TYPE 24 FRAME:
 - MATERIAL MAY CONFORM TO ASTM A-36
 - FRAME SHALL BE GALVANIZED AFTER FABRICATION PER ASTM A-123
 - FRAME SHALL MEET H-20 WHEEL LOADING
9. PRECAST STORM INLET TYPE "A" DRAINAGE INLET ASSEMBLY SHALL BE PIRANHA PIPE & PRECAST OR APPROVED EQUAL.

CALTRANS TYPE 24 FRAME

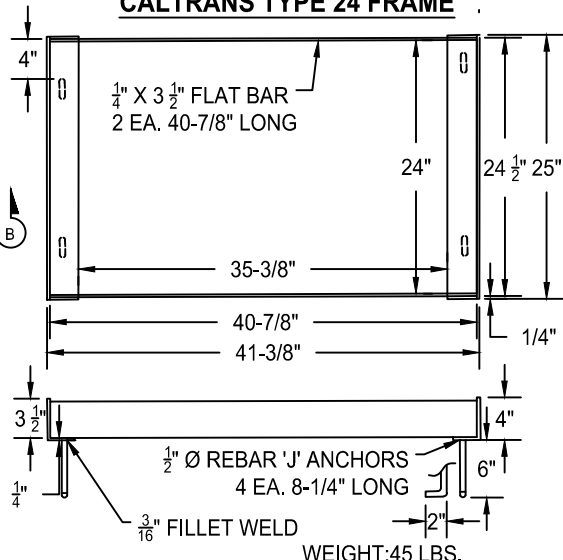

WEIGHT: 45 LBS.
ALL GRATES SHALL BE PEDESTRIAN AND BICYCLE RATED TYPE

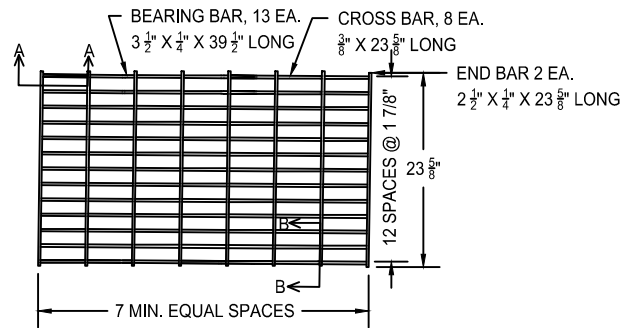

GRATE DETAIL

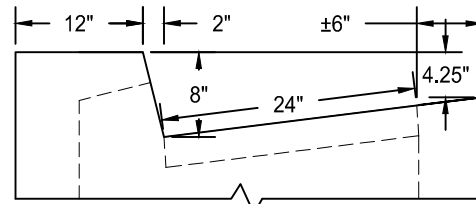

**ROOT CREEK WATER DISTRICT
STANDARD DETAIL**

PREPARED BY: STEPHEN GRISEZ
NICK BRUNO, RCWD PRESIDENT

**CAST IN PLACE STORM TYPE A
DRAINAGE INLET**

SCALE: NOT TO SCALE

DATE ADOPTED: 8-12-2019

D-8

SHEET 8 OF 17

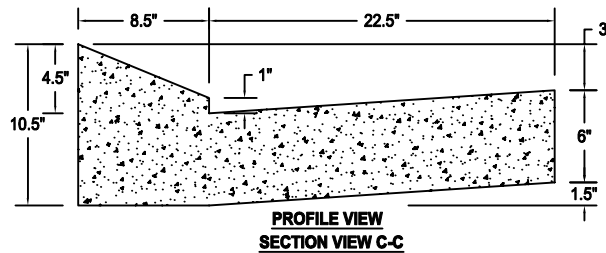
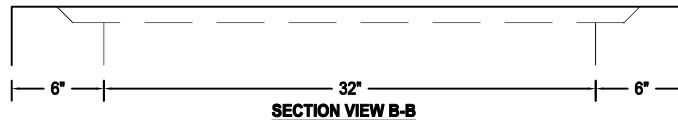
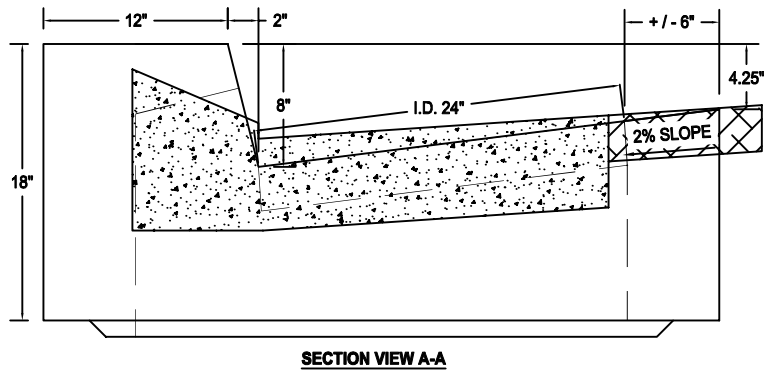
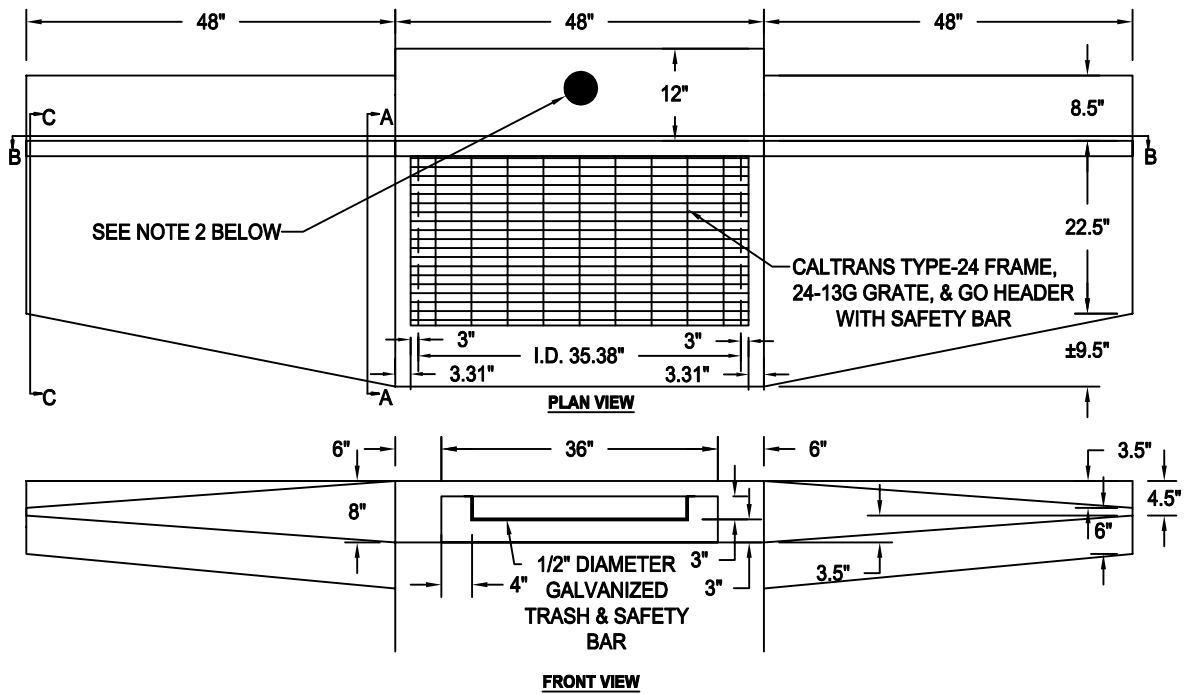

NOTE:

1. PRECAST STORM INLET TYPE "A" DRAINAGE INLET ASSEMBLY SHALL BE PIRANHA PIPE & PRECAST OR APPROVED EQUAL.
2. DURACAST #SDG MARKER WITH ABRASION & UV RESISTANT FEATURES, LABELED "CLEAN WATER ONLY" AND "DRAINS TO GROUNDWATER", OR APPROVED EQUAL, CENTER EACH WAY AT TOP OF CURB, EPOXY IN PLACE PER MANUFACTURER RECOMMENDATIONS.



**ROOT CREEK WATER DISTRICT
STANDARD DETAIL**

PREPARED BY: STEPHEN GRISEZ
Stephen Grisez
NICK BRUNO, RCWD PRESIDENT

**STORM TYPE A DRAINAGE INLET
4.5 IN DRIVE OVER CURB TOPOUT**

SCALE: NOT TO SCALE

DATE ADOPTED: 8-12-2019

D-10

SHEET 10 OF 17

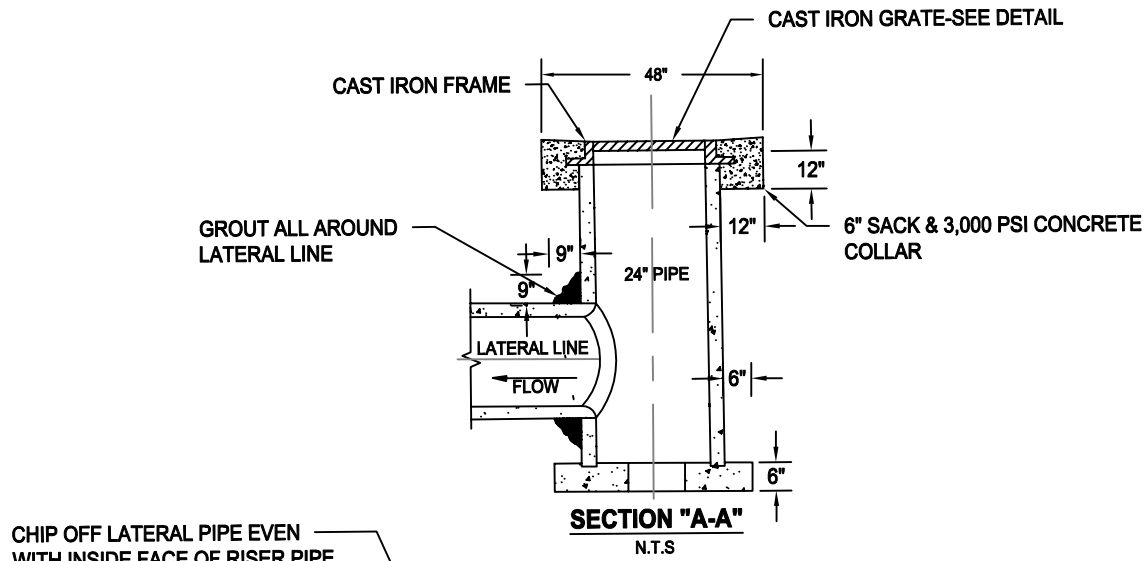

CHIP OFF LATERAL PIPE EVEN WITH INSIDE FACE OF RISER PIPE. SEE NOTE 5.

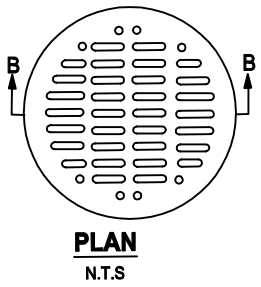
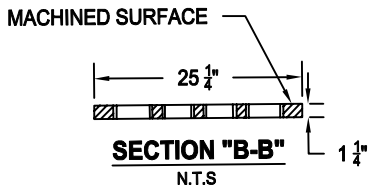
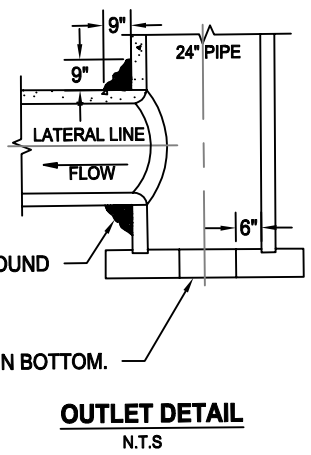
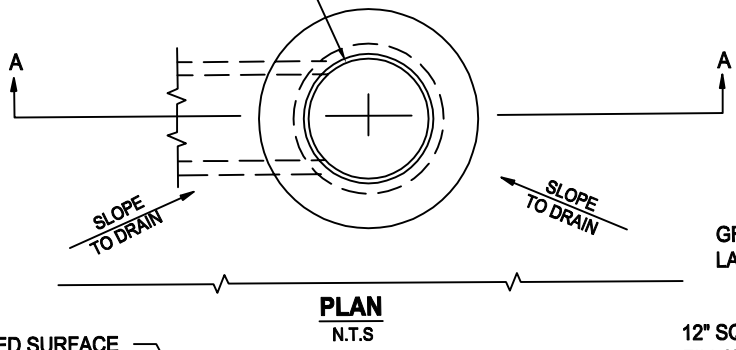

24" CAST IRON GRATE
GRATE DETAIL

NOTES:

1. 24" CONCRETE RISER PIPE SHALL BE A.S.T.M. DESIGNATION C 118; 24" RCP PIPE, CLASS 3 OR BETTER; OR MANHOLE GRADE RINGS.
2. BREAK OUT RISER PIPE AND CUT LATERAL LINE NEATLY ALONG JOINT. FILL JOINT SPACE WITH MORTAR.
3. 6 SACK & 3,000 PSI CONCRETE BASE SHALL BE PROVIDED FOR 24" RISER PIPE AS SHOWN.
4. COST OF GRATE AND RING SHALL BE INCLUDED IN PRICE OF INLET OR OUTLET.
5. AT THE CONTACT POINT BETWEEN THE LATERAL LINE AND THE INLET WALL A SMOOTH 3" RADIUS CURVE SHALL BE CONSTRUCTED.
6. FLOOR OF THE INLET SHALL SLOPE FROM ALL WALLS TO THE LATERAL LINE AND SHALL BE GIVEN A STEEL TROWELED FINISH.
7. COST OF THE A.C. PAD AND ALL GRADING DEFINED AT IMPROVEMENT PLANS IS TO BE INCLUDED IN PRICE OF INLET OR OUTLET.



**ROOT CREEK WATER DISTRICT
STANDARD DETAIL**

PREPARED BY: STEPHEN GRISEZ
Stephen Grisez
NICK BRUNO, RCWD PRESIDENT

**STORM TYPE B DRAINAGE INLET
WITH SLOTTED MANHOLE GRATE**

SCALE: NOT TO SCALE
DATE ADOPTED: 8-12-2019

D-11
SHEET 11 OF 17

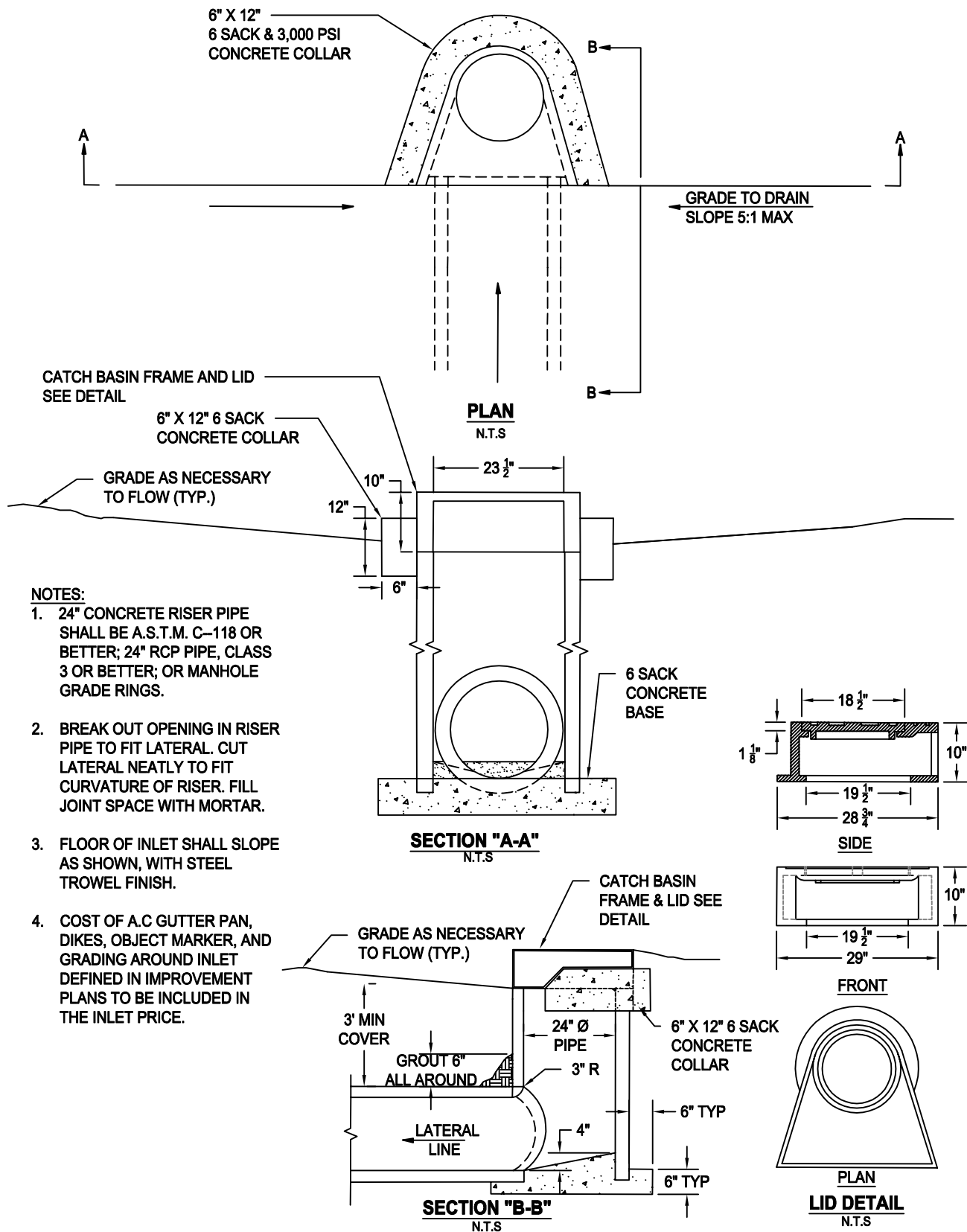

NOTES:

1. 24" CONCRETE RISER PIPE SHALL BE A.S.T.M. C-118 OR BETTER; 24" RCP PIPE, CLASS 3 OR BETTER; OR MANHOLE GRADE RINGS.
2. BREAK OUT OPENING IN RISER PIPE TO FIT LATERAL. CUT LATERAL NEATLY TO FIT CURVATURE OF RISER. FILL JOINT SPACE WITH MORTAR.
3. FLOOR OF INLET SHALL SLOPE AS SHOWN, WITH STEEL TROWEL FINISH.
4. COST OF A.C GUTTER PAN, DIKES, OBJECT MARKER, AND GRADING AROUND INLET DEFINED IN IMPROVEMENT PLANS TO BE INCLUDED IN THE INLET PRICE.



**ROOT CREEK WATER DISTRICT
STANDARD DETAIL**

PREPARED BY: *Stephen Grisez*
STEPHEN GRISEZ
NICK BRUNO, RCWD PRESIDENT

**STORM TYPE C DRAINAGE INLET
WITH CURB FACE OPENING**

SCALE: NOT TO SCALE

DATE ADOPTED: 8-12-2019

D-12

SHEET 12 OF 17

3' X 4' CHRISTY U-52 DRAINAGE INLET OR APPROVED EQUAL, NON-TRAFFIC GALVANIZED STEEL BOLT DOWN GRATE, STEPS ARE REQUIRED AT ALL INLETS GREATER THAN 3' IN DEPTH.

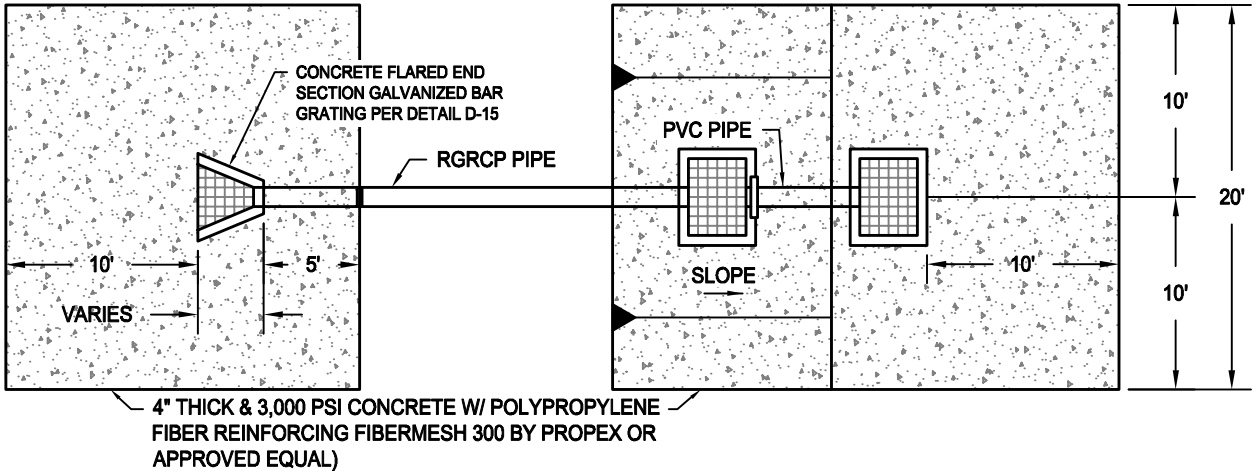
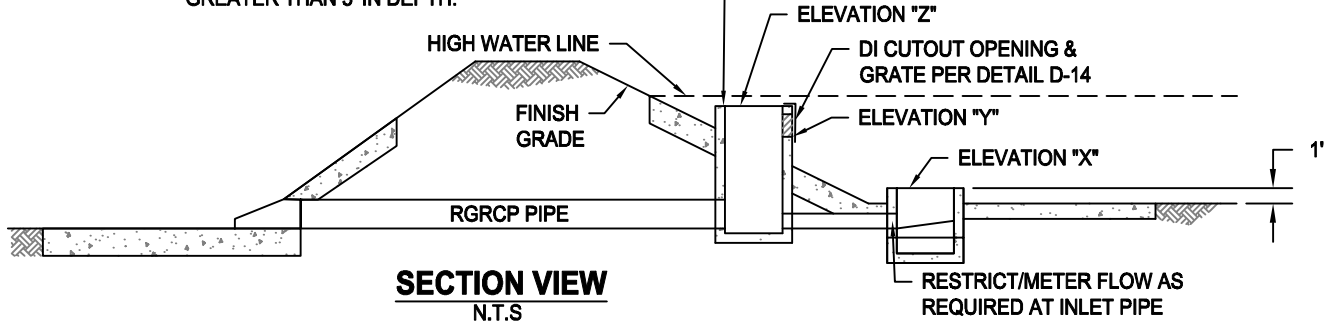

OVER FLOW OUTFALL WEIR
N.T.S.

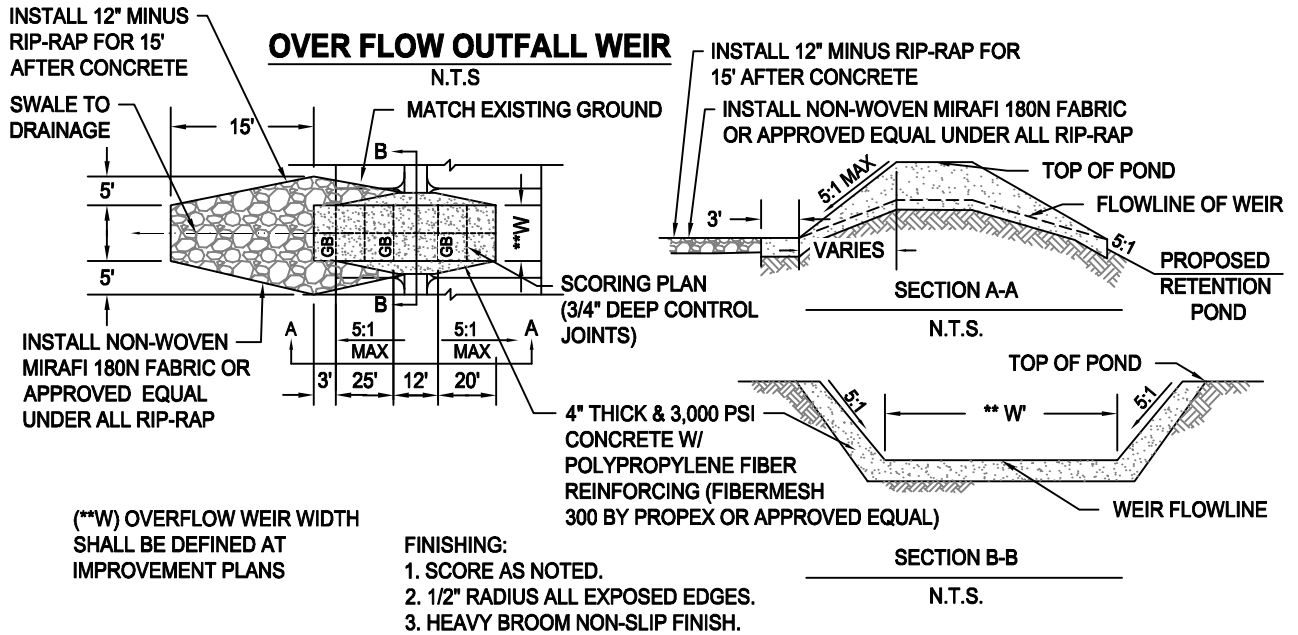

(**W) OVERFLOW WEIR WIDTH SHALL BE DEFINED AT IMPROVEMENT PLANS

- FINISHING:
1. SCORE AS NOTED.
 2. 1/2" RADIUS ALL EXPOSED EDGES.
 3. HEAVY BROOM NON-SLIP FINISH.



**ROOT CREEK WATER DISTRICT
STANDARD DETAIL**

PREPARED BY: *Stephen Grisez*
STEPHEN GRISEZ
NICK BRUNO, RCWD PRESIDENT

**STORM DRAINAGE BASIN METERED
OUTLET ASSEMBLY & OVERFLOW WEIR**

SCALE: NOT TO SCALE
DATE ADOPTED:

D-13
SHEET 13 OF 17

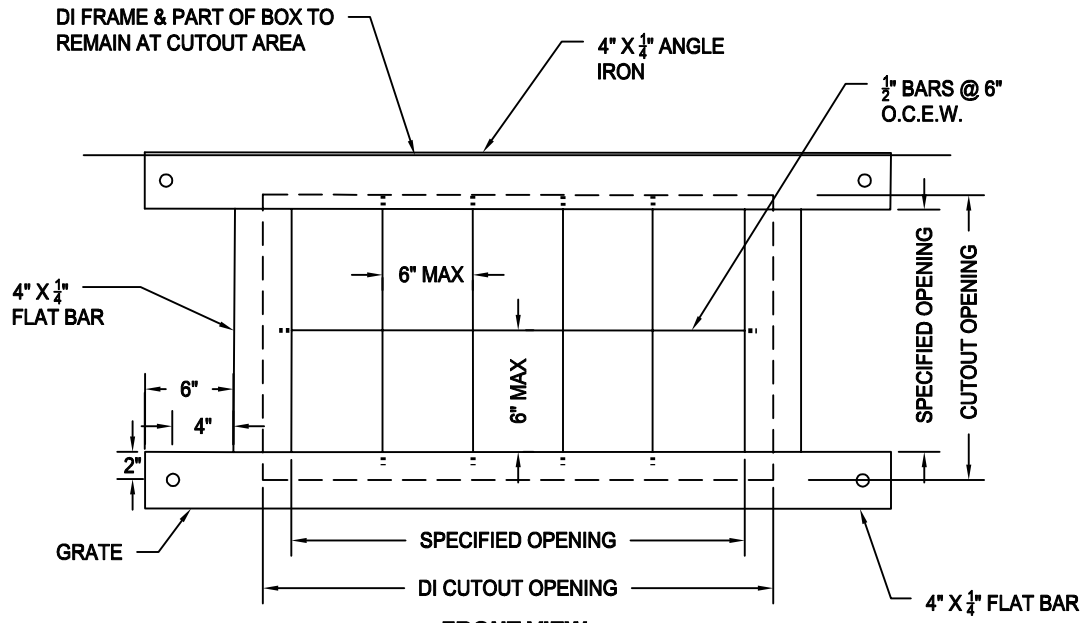

FRONT VIEW
N.T.S

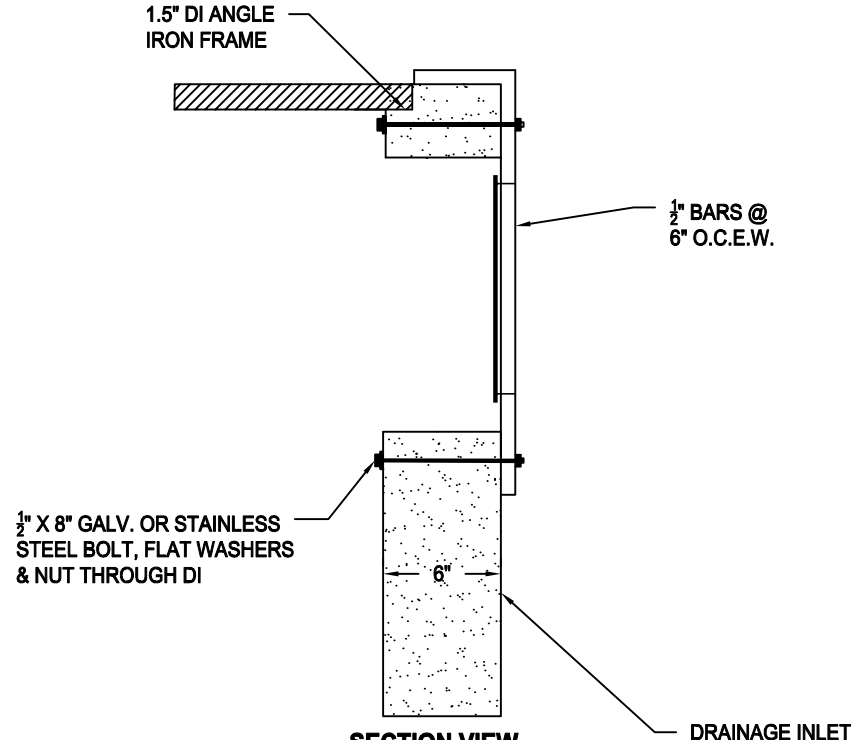

SECTION VIEW
N.T.S

NOTE:
1. DEBRIS RACK AND ALL HARDWARE TO BE HOT DIP GALVANIZED AFTER EACH FABRICATION PER ASTM A153



**ROOT CREEK WATER DISTRICT
STANDARD DETAIL**

PREPARED BY: *Stephen Grisez*
STEPHEN GRISEZ
NICK BRUNO, RCWD PRESIDENT

**STORM DRAINAGE INLET CUTOUT
OPENING & GRATE DETAIL**

SCALE: NOT TO SCALE
DATE ADOPTED: 8-12-2019

D-14
SHEET 14 OF 17

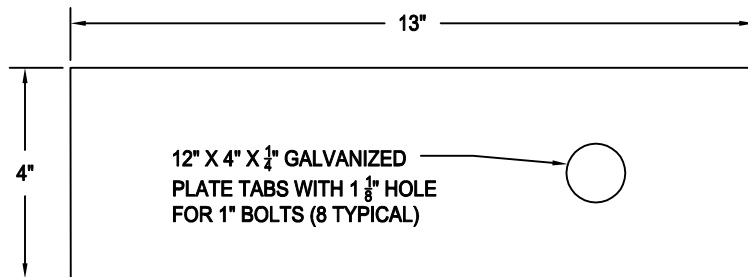

TOP VIEW



SIDE VIEW

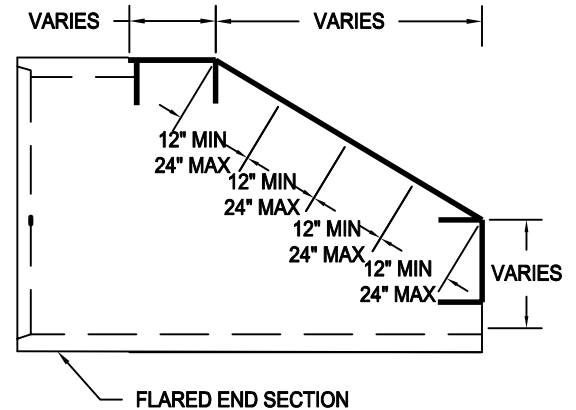
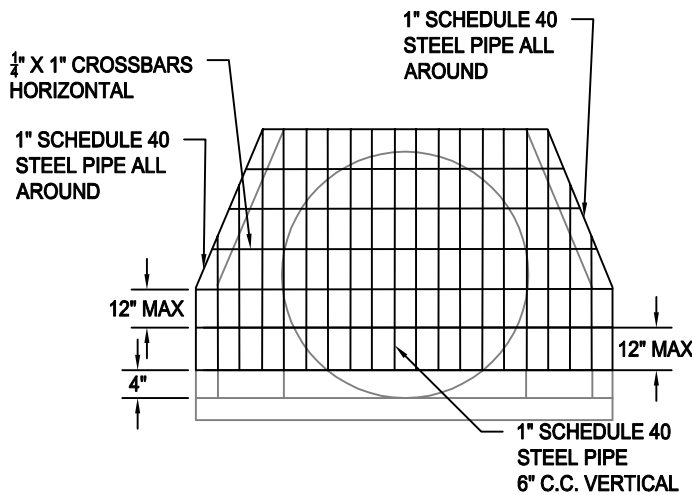
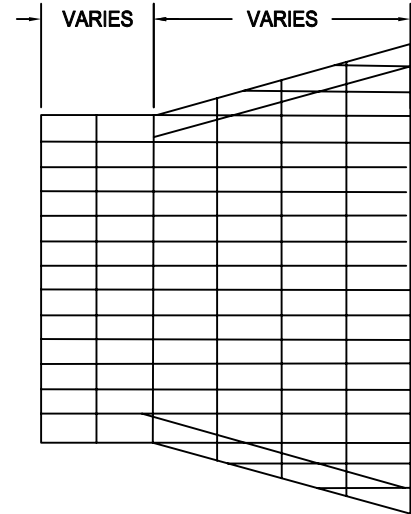

NOTES:

1. STORM FLARED END SECTIONS ARE REQUIRED AT ALL PIPE LARGER THAN 12" IN DIAMETER.
2. THIS DETAIL PROVIDES BASIC REQUIRED CONCEPT AND MINIMUM DIMENSIONS.
3. SHOP DRAWINGS SHALL BE PROVIDED UPON REQUEST FOR REVIEW AND COMMENT PRIOR TO FABRICATION.
4. STORM FLARED END SECTION AND ALL HARDWARE SHALL BE HOT DIP GALVANIZED AFTER FABRICATION PER ASTM A153.
5. ALL NUTS BOLTS, AND WASHERS SHALL BE HOT DIP GALVANIZED OR STAINLESS STEEL.



**ROOT CREEK WATER DISTRICT
STANDARD DETAIL**

PREPARED BY: STEPHEN GRISEZ
Stephen Grisez
NICK BRUNO, RCWD PRESIDENT

**STORM FLARED END SECTION
TRASH & SAFETY RACK**

SCALE: NOT TO SCALE

DATE ADOPTED: 8-12-2019

D-15

SHEET 15 OF 17

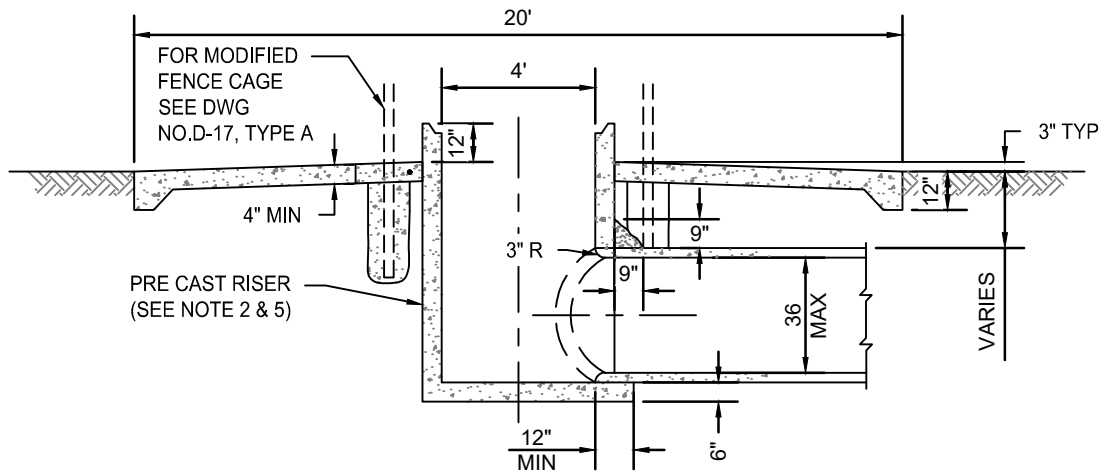

SECTION "A-A"

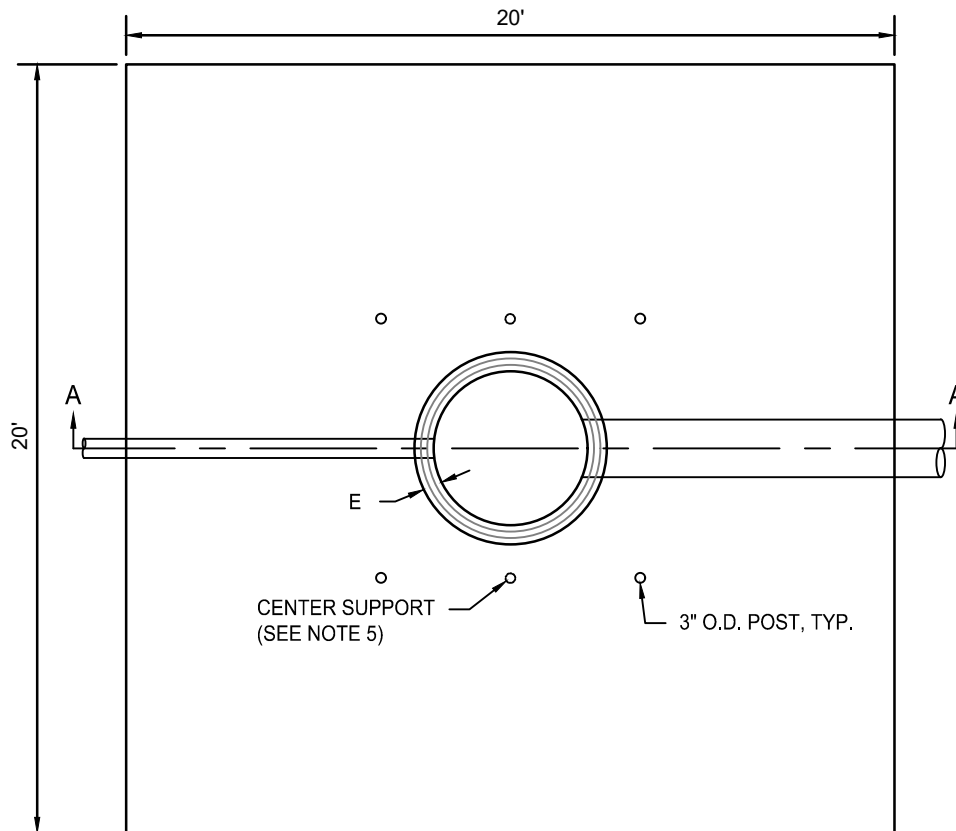

PLAN

NOTES:

1. BASE IN OUTFALL SHALL BE PRECAST.
2. SHAFT PIPE SHALL BE PRECAST.
3. PRE-CAST RISERS SHALL COMPLY WITH ASTM C-478, TYPE II CEMENT.
4. TOP SLAB SHALL BE CAST IN PLACE.
5. CAST IN PLACE TOP SLAB SHALL BE DOWELED INTO PRECAST RISER WITH #4 REBAR AT 18" O.C.
6. CONCRETE TO INCLUDE 2LB/CY OF FIBERMESH OR APPROVED EQUIVALENT
7. FOR MODIFIED FENCE CAGE: SEE DWG, D-16, TYPE A
8. IF THE REQUIRED STRUCTURE EXCEEDS THE LARGEST DIMENSIONS SPECIFIED BY THE ROOT CREEK WATER DISTRICT STANDARD DETAIL, THE FRESNO METROPOLITAN FLOOD CONTROL DISTRICT (FMFCD) STANDARD DETAILS MAY BE USED TO ACCOMMODATE THE LARGER SIZES. FOR STRUCTURES LARGER THAN THOSE COVERED BY RCWD STANDARDS, THE STRUCTURE MAY BE CAST-IN-PLACE PER FMFCD DETAILS, SUBJECT TO RCWD APPROVAL.



ROOT CREEK WATER DISTRICT
STANDARD DETAIL

STORM OUTFALL STRUCTURE
TYPE A

PREPARED BY: STEPHEN GRISEZ

SCALE: NOT TO SCALE

D-16

NICK BRUNO, RCWD PRESIDENT

DATE ADOPTED: 12-8-2025

SHEET 16 OF 17

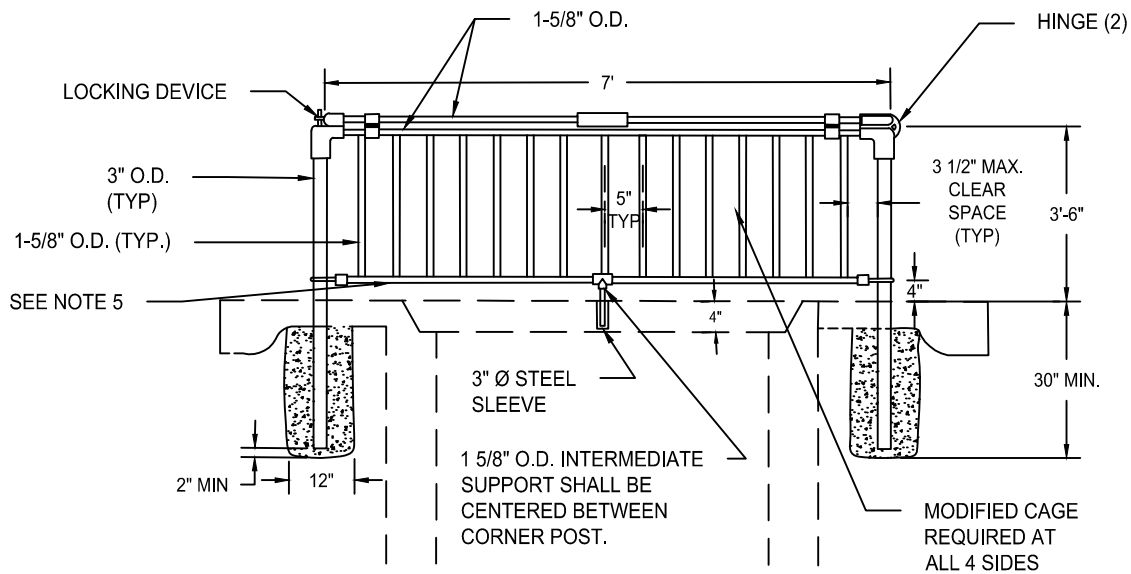

PROFILE

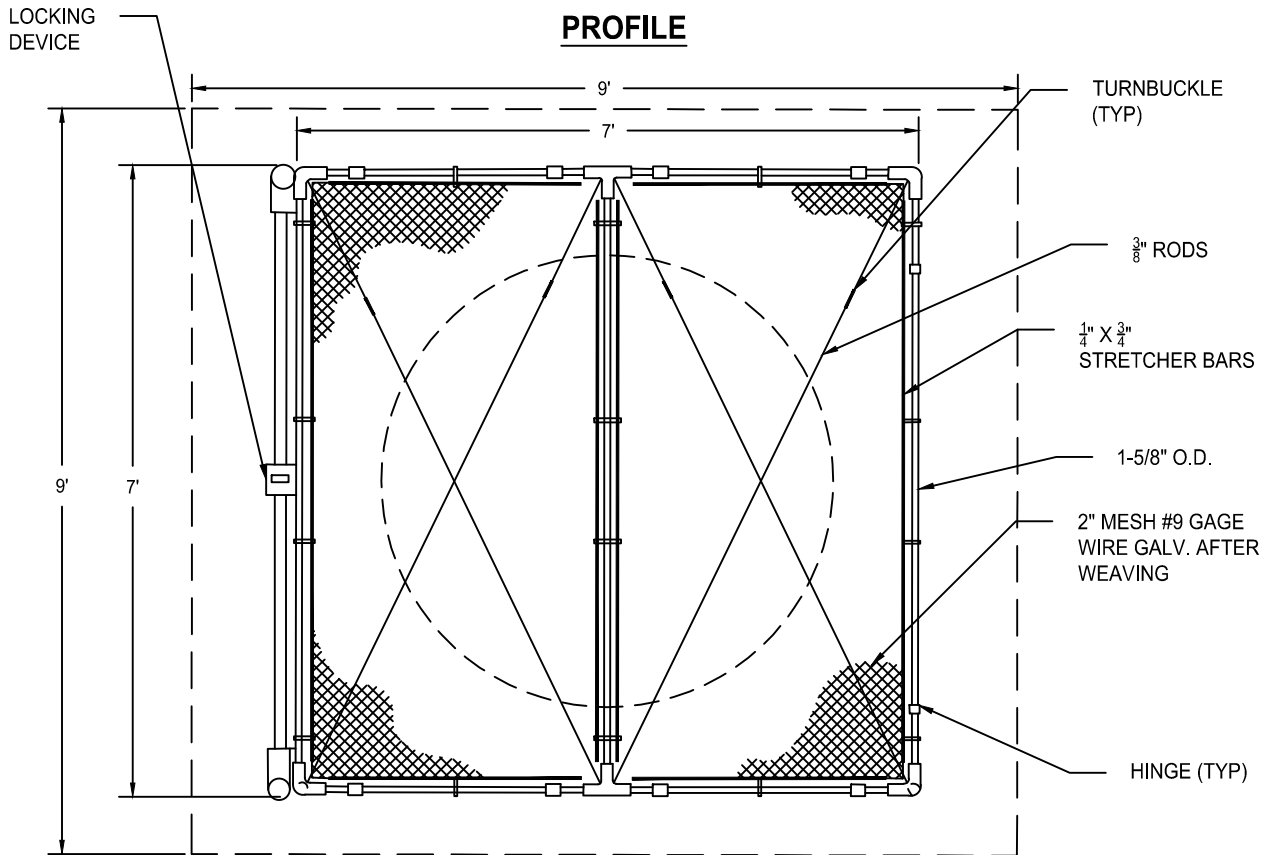

PLAN

NOTES:

1. LOCKING DEVICE SHALL BE APPROVED BY ENGINEER.
2. LOCK WILL BE SUPPLIED BY THE DISTRICT.
3. ALL METAL PARTS SHALL BE GALVANIZED.
4. PIPE INTERSECTIONS MAY EITHER BE TEE FITTINGS OR CUT AND WELDED CONNECTIONS AND RE- GALVANIZED.
5. IF THE REQUIRED STRUCTURE EXCEEDS THE LARGEST DIMENSION SPECIFIED BY THE ROOT CREEK WATER DISTRICT STANDARD DETAIL, THE FRESNO METROPOLITAN FLOOD CONTROL DISTRICT (FMFCD) STANDARD DETAILS MAY BE USED TO ACCOMMODATE THE LARGER SIZES, SUBJECT TO RCWD APPROVAL.



ROOT CREEK WATER DISTRICT
STANDARD DETAIL

PREPARED BY: STEPHEN GRISEZ
Stephen Grisez
NICK BRUNO, RCWD PRESIDENT

STORM TYPE A OUTFALL
MODIFIED FENCE CAGE

SCALE: NOT TO SCALE

DATE ADOPTED: 12-8-2025

D-17

SHEET 17 OF 17

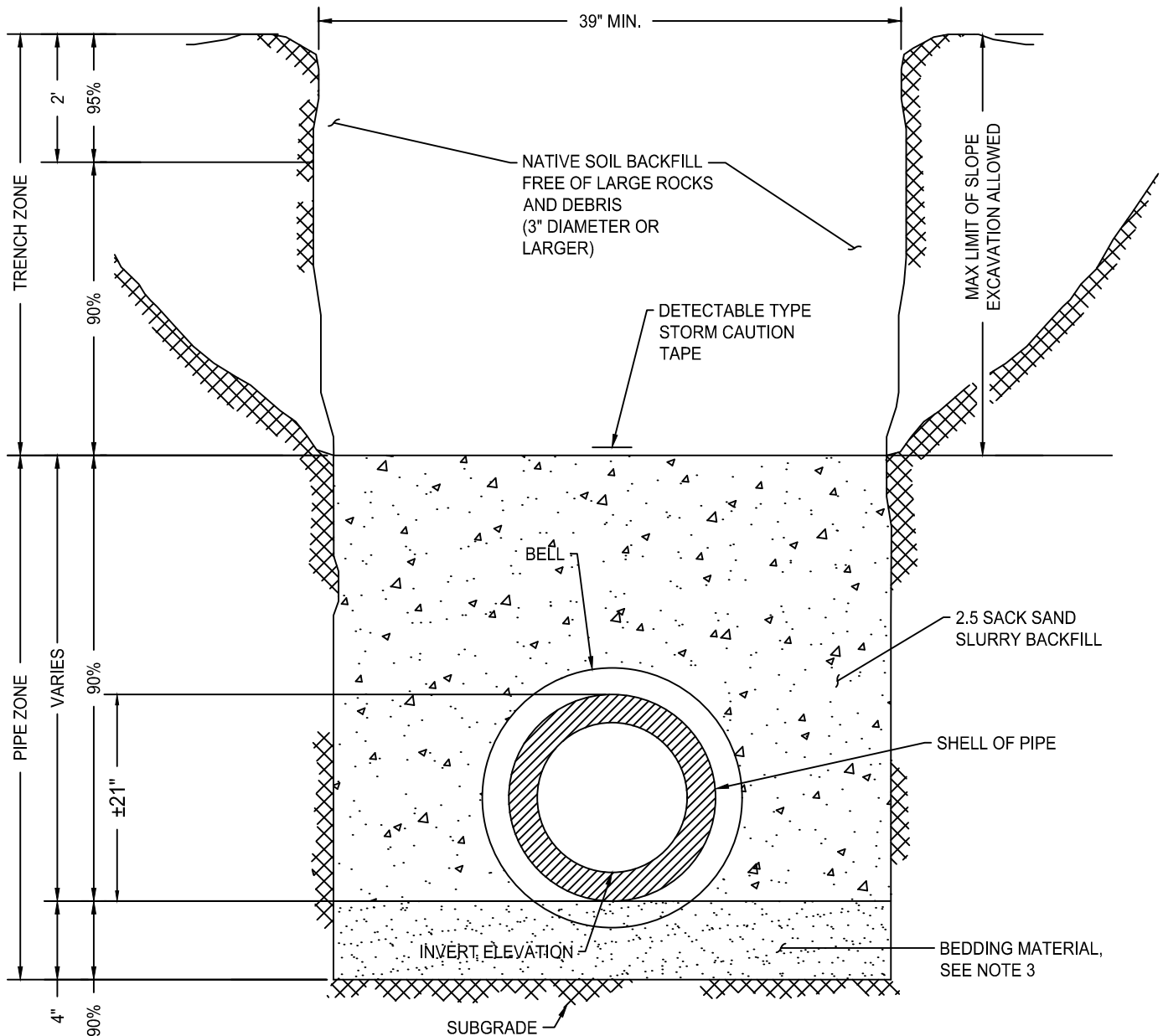

NOTES:

1. APPLICABLE FOR 18" POLYPROPYLENE (PP) STORM DRAIN AND INSTALLATION WITH LESS THAN 3' MINIMUM COVER.
2. GRAVITY STORM PIPE AND FITTINGS SHALL BE POLYPROPYLENE WITH RUBBER GASKET JOINTS CONFORMING TO ASTM D 3212.
3. BEDDING MATERIAL SHALL CONFORM TO ASTM D2321, CLASS II MATERIAL.
4. PIPE ZONE MATERIAL SHALL BE 2.5 SACK CEMENT SAND SLURRY.
5. COMPACTION TESTING OF ALL TRENCHES SHALL BE REQUIRED AS SPECIFIED IN STANDARD SPECIFICATIONS AND AS DIRECTED BY THE DISTRICT ENGINEER & OWNER.
6. SPECIFIED COMPACTION REQUIREMENTS ARE DISTRICT MINIMUMS AND IN THE EVENT OF CONFLICTS WITH MANUFACTURER RECOMMENDATIONS, THE MORE RESTRICTIVE REQUIREMENT SHALL PREVAIL.
7. TRENCH PATCH REQUIREMENTS ARE SPECIFIED AT STANDARD DETAIL ST-4.
8. STORM PIPE SUBJECT TO STORM WATER RETENTION DURING STORM OR OTHER RELATED EVENTS SHALL REQUIRE HYDROSTATIC TESTING PER STANDARD SPECIFICATIONS.
9. THIS DETAIL SHALL FULLY COMPLY WITH STANDARDS W-35 AND W-36 AND IS NOT INTENDED TO BE USED AS A MITIGATION MEASURE.
10. THIS DETAIL MAY ONLY BE USED WHEN WRITTEN APPROVAL IS GRANTED BY THE DISTRICT ENGINEER.

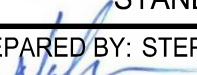
	ROOT CREEK WATER DISTRICT STANDARD DETAIL	PP STORM PIPE BEDDING & CEMENT SLURRY BACKFILL	
	PREPARED BY: STEPHEN GRISEZ  NICK BRUNO, RCWD PRESIDENT	SCALE: NOT TO SCALE DATE ADOPTED: 6-8-2026	D-19 SHEET 19 OF 20

SANITITE HP MANHOLE ADAPTER (OR APPROVED EQUAL)			
PIPE SIZE	ADAPTER OD	ADS PRODUCT CODES	A-LOK®
18"	22"	1822AAPP	710

NYLOPLAST MANHOLE ADAPTER (OR APPROVED EQUAL)			
PIPE SIZE	ADAPTER OD	NYLOPLAST PRODUCT CODES	A-LOK®
18"	18.7"	1868AG	610

PRESS SEAL® SYSTEMS (OR APPROVED EQUAL)				
PIPE SIZE	PIPE OD	CORRUGATED PPE ADAPTER GASKET	CAST-A-SEAL	PSX: DIRECT DRIVE
18"	21.2"	1850PS	CAS 802	24A

TRELLEBORG (OR APPROVED EQUAL)			
PIPE SIZE	PIPE OD	CORRUGATED PPE ADAPTER GASKET	KOR-N-SEAL
18"	21.2"	CGA-18A	S206-24L (SERIES I OR II) S306-24L (SERIES 306)

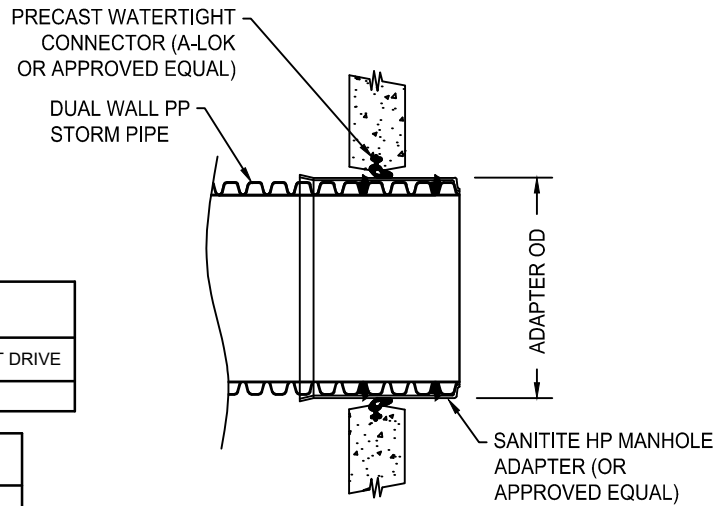

**COMPRESSION GASKET (PRECAST)
CONNECTION WITH SANITITE
ADAPTER (OR APPROVED EQUAL)**

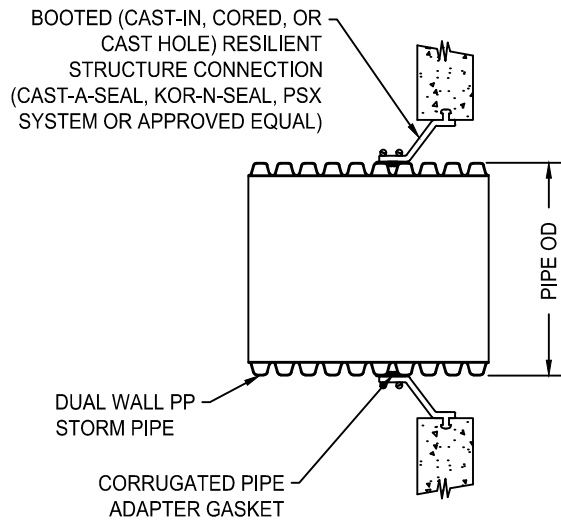

**BOOTED
CONNECTION**

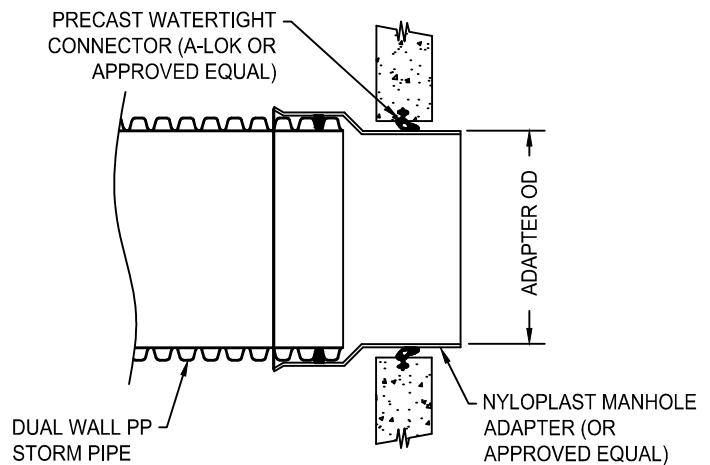

**COMPRESSION GASKET (PRECAST) CONNECTION
WITH NYLOPLAST ADAPTER (OR APPROVED EQUAL)**

NOTES:

1. APPLICABLE FOR 18" POLYPROPYLENE (PP) STORM DRAIN CONNECTIONS TO CONCRETE STRUCTURES. CONTRACTOR TO ENSURE ALL CONCRETE STRUCTURES AND ADAPTER PARTS ARE COMPATIBLE FOR 18" STORM PIPE.
2. CONNECTIONS SHALL BE WATERTIGHT AND FLEXIBLE USING A MANUFACTURED RESILIENT RUBBER BOOT AND PIPE ADAPTER GASKET SYSTEM OR WITH A PRECAST COMPRESSION GASKET SYSTEM AND MANHOLE ADAPTER WITH PIPE ADAPTER GASKET SYSTEM COMPATIBLE WITH PP AND CONCRETE MANHOLES. MANUFACTURER PRODUCT INFORMATION IN THIS DETAIL IS PROVIDED FOR REFERENCE ONLY AND SHOULD BE VERIFIED BY THE CONTRACTOR FOR APPLICABILITY BEFORE PURCHASING.
3. PERFORMANCE IS HIGHLY DEPENDENT ON INSTALLATION. CONTRACTOR MUST ENSURE MANHOLE GASKET IS UNIFORMLY SEATED AROUND STRUCTURE ADAPTER. EXTRA PRECAUTIONS MUST BE TAKEN TO PREVENT DIFFERENTIAL SETTLEMENT BETWEEN THE PIPE AND MANHOLE.
4. PIPE INSTALLATION SHALL MEET THE REQUIREMENTS OF STANDARD DETAILS D-18 OR D-19, WHICHEVER IS APPLICABLE.
5. COMPACTION TESTING OF ALL TRENCHES SHALL BE REQUIRED AS SPECIFIED IN STANDARD SPECIFICATIONS AND AS DIRECTED BY THE DISTRICT ENGINEER & OWNER.
6. SPECIFIED COMPACTION REQUIREMENTS ARE DISTRICT MINIMUMS AND IN THE EVENT OF CONFLICTS WITH MANUFACTURER RECOMMENDATIONS, THE MORE RESTRICTIVE REQUIREMENT SHALL PREVAIL.
7. STORM PIPE SUBJECT TO STORM WATER RETENTION DURING STORM OR OTHER RELATED EVENTS SHALL REQUIRE HYDROSTATIC TESTING PER STANDARD SPECIFICATIONS.
8. THIS DETAIL MAY ONLY BE USED WHEN WRITTEN APPROVAL IS GRANTED BY THE DISTRICT ENGINEER.



**ROOT CREEK WATER DISTRICT
STANDARD DETAIL**

PREPARED BY: STEPHEN GRISEZ
Stephen Grisez
NICK BRUNO, RCWD PRESIDENT

**PP STORM PIPE CONNECTION TO
MANHOLES**

SCALE: NOT TO SCALE

DATE ADOPTED: 6-8-2026

D-20

SHEET 20 OF 20

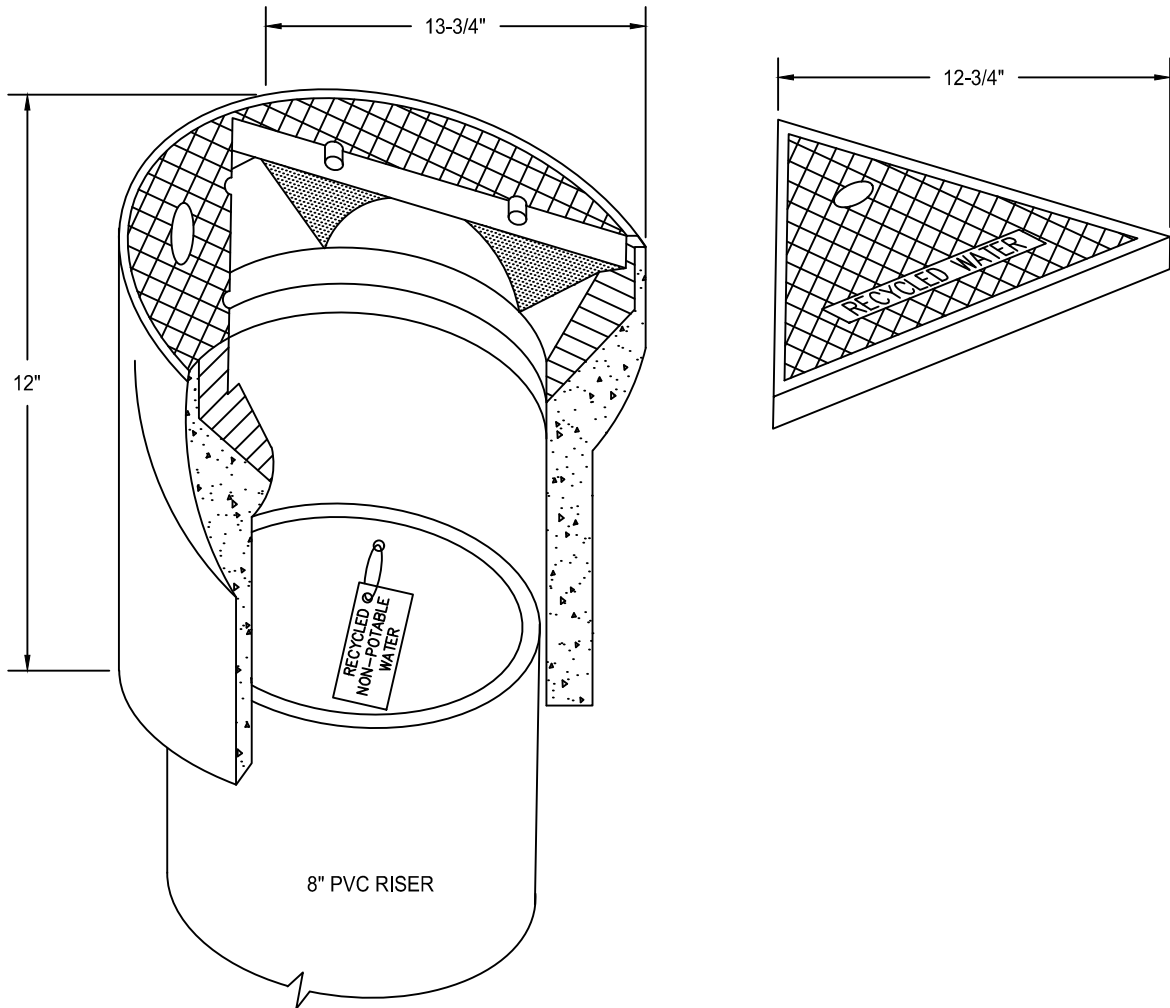

NOTES:

1. VALVE 80X SHALL BE CHRISTY MODEL G4 BOX TRAFFIC VALVE BOX (10" I.D. X 12" HIGH) OR APPROVED EQUAL.
2. VALVE BOX LID SHALL BE CHRISTY MODEL G4C CAST IRON, OR APPROVED EQUAL. THE WORDS "RECYCLED WATER" SHALL BE STAMPED OR CAST, OR HARDFACE WELDED ONTO LID.
3. ALL OTHER ASPECTS OF THE BOX, INCLUDING CONCRETE COLLAR, RISER, AND TRACER WIRE SHALL CONFORM TO STANDARD DRAWING ____, WATER VALVE & WELL".
4. HANG 2"x4" METAL TAG LABELED "RECYCLED, NON-POTABLE WATER" NEAR THE TOP OF THE PVC RISER.



**ROOT CREEK WATER DISTRICT
STANDARD DETAIL**

PREPARED BY: STEPHEN GRISEZ
NICK BRUNO, RCWD PRESIDENT

RECYCLED WATER VALVE BOX

SCALE: NOT TO SCALE

DATE ADOPTED: 8-12-2019

RW1

SHEET 1 OF 2

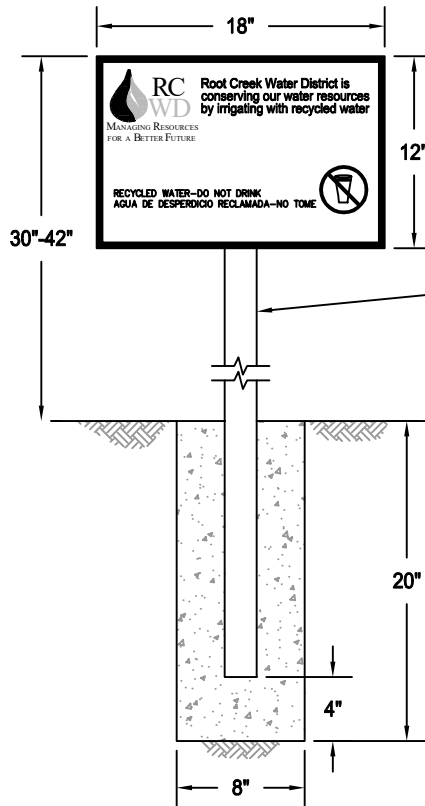

2"x2"x12" GAUGE GALVANIZED UNISTRUT STEEL POST. U-CHANNEL, OR BOX POST MINIMUM 1 1/2" WIDE, OR OTHER MATERIALS AS APPROVED BY THE DISTRICT ENGINEER

NOTES:

1. ALL USE AREAS WHERE RECYCLED WATER IS USED THAT ARE ACCESSIBLE TO THE PUBLIC SHALL BE POSTED WITH ONE OR MORE INFORMATION SIGNS IN CONSPICUOUS LOCATIONS THAT ARE VISIBLE TO THE PUBLIC.
2. INFORMATION SIGNS SHALL BE CONSTRUCTED OF 0.080" THICK ALUMINUM REFLECTIVE SHEETING WITH A PURPLE BACKGROUND AND WHITE LETTERING AND A 3M#1160 GRAFFITI FILM APPLIED, OR APPROVED EQUAL.
3. LOCATION OF SIGN AT EACH RECYCLED WATER SERVICE TO BE DETERMINED BY THE ENGINEER.



**ROOT CREEK WATER DISTRICT
STANDARD DETAIL**

PREPARED BY: STEPHEN GRISEZ
Stephen Grisez
NICK BRUNO, RCWD PRESIDENT

RECYCLED WATER ID SIGN 18 IN X 12 IN

SCALE: NOT TO SCALE

DATE ADOPTED: 8-12-2019

RW2

SHEET 2 OF 2

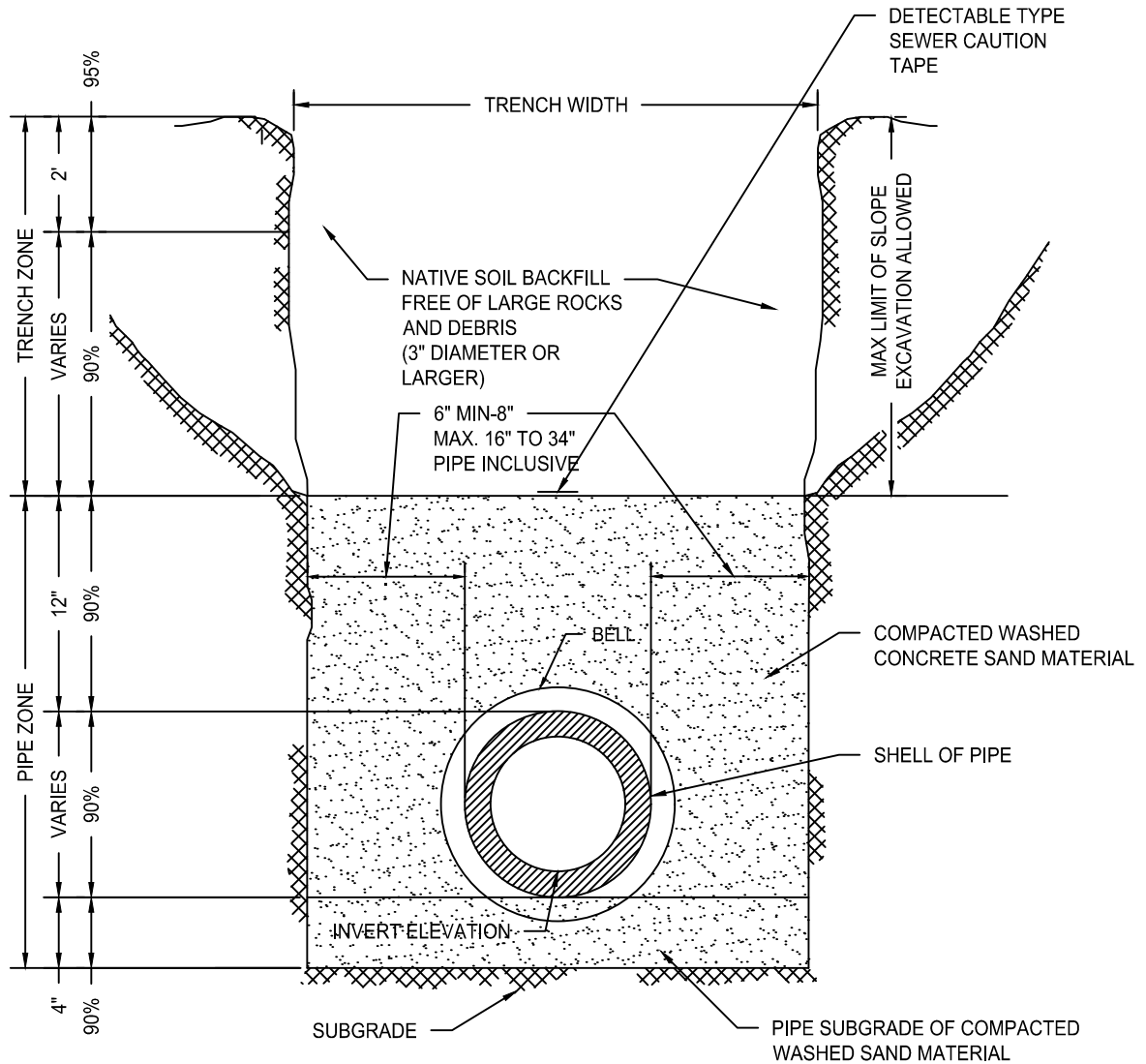

NOTES:

1. APPLICABLE FOR INSTALLATION WITH 3' OR GREATER MINIMUM COVER.
2. FOR COVER LESS THAN 3' SEE STANDARD DETAIL S-2.
3. GRAVITY SEWER PIPE AND FITTINGS SHALL BE PVC, SDR-35 WITH INTEGRAL RUBBER GASKET JOINTS.
4. PIPE ZONE MATERIAL SHALL BE WASHED CONCRETE SAND FREE OF SILT AND ORGANIC MATERIAL. PIPE ZONE SHALL INITIALLY BE FILLED TO SPRINGLINE OF PIPE, WATERED, AND HAUNCHES COMPACTED WITH A WACKER TYPE COMPACTOR 4" WIDE X 12" LONG SHOE PLATE.
5. COMPACTION TESTING OF ALL TRENCHES SHALL BE REQUIRED AS SPECIFIED AT STANDARD SPECIFICATIONS AND AS DIRECTED BY THE DISTRICT ENGINEER & OWNER.
6. SPECIFIED COMPACTION REQUIREMENTS ARE DISTRICT MINIMUMS AND IN THE EVENT OF CONFLICTS, THE MORE RESTRICTIVE REQUIREMENT SHALL PREVAIL.
7. TRENCH PATCH REQUIREMENTS ARE SPECIFIED AT STANDARD DETAIL ST-4.
8. BALL & FLUSH, AIR TEST, MANDREL TEST, AND TV INSPECTION REQUIRED PER STANDARD SPECIFICATIONS. SEWER SHALL BE TESTED AFTER JOINT TRENCH IS INSTALLED AND BACKFILLED.



**ROOT CREEK WATER DISTRICT
STANDARD DETAIL**

PREPARED BY: STEPHEN GRISEZ
Stephen Grisez
NICK BRUNO, RCWD PRESIDENT

**SEWER SAND PIPE BEDDING &
TRENCH BACKFILL**

SCALE: NOT TO SCALE

DATE ADOPTED: 4-12-2021

S-1

SHEET 1 OF 13

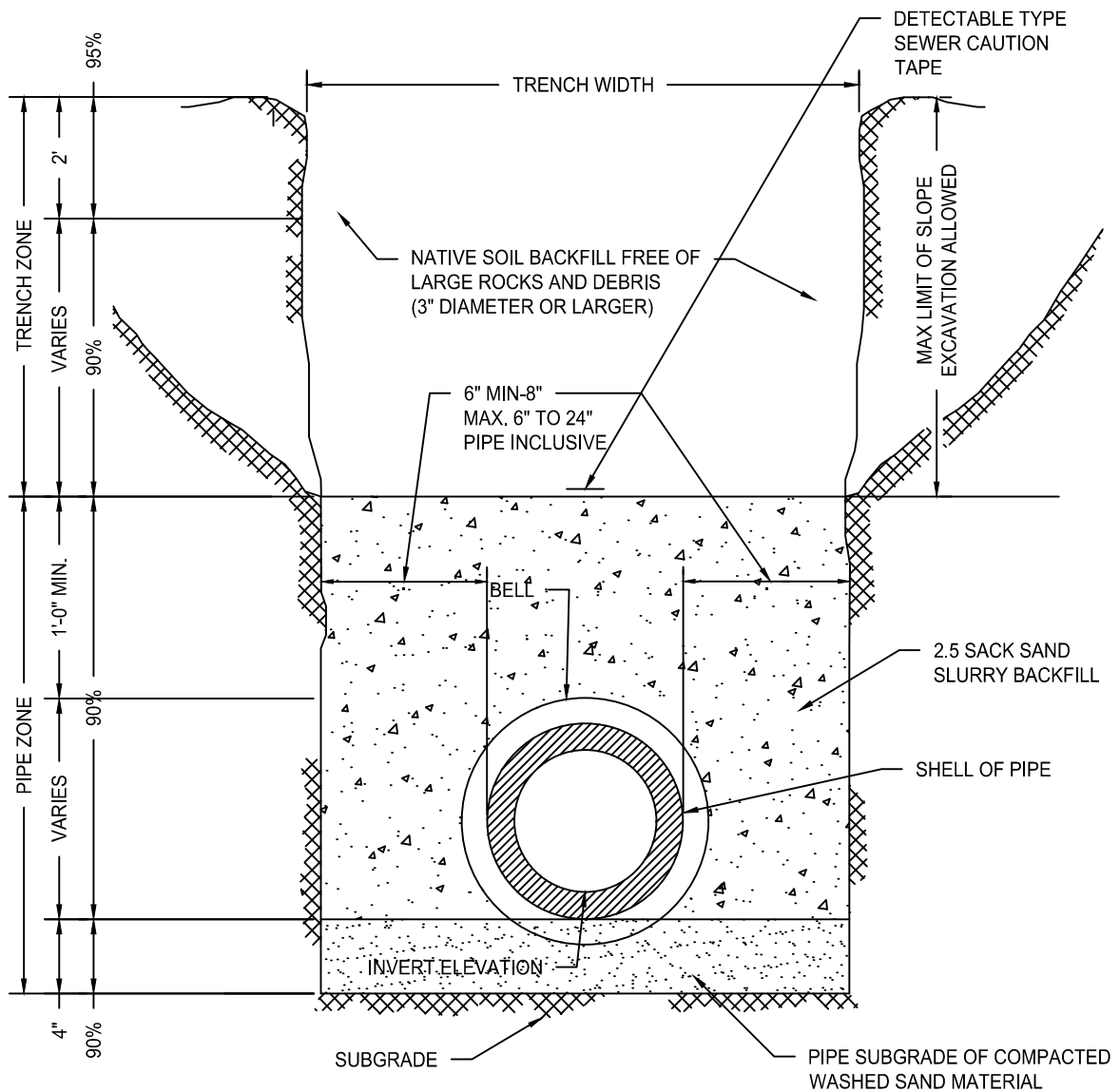

NOTES:

1. APPLICABLE FOR INSTALLATION WITH LESS THAN 3' MINIMUM COVER
2. GRAVITY SEWER PIPE & FITTINGS SHALL BE PVC, SDR-35 WITH INTEGRAL RUBBER GASKET JOINTS.
3. PIPE ZONE BEDDING MATERIAL SHALL BE WASHED CONCRETE SAND FREE OF SILT AND ORGANIC MATERIAL.
4. PIPE ZONE MATERIAL SHALL BE 2.5 SACK CEMENT SAND SLURRY.
5. COMPACTION TESTING OF ALL TRENCHES SHALL BE REQUIRED AS SPECIFIED AT STANDARD SPECIFICATIONS AND AS DIRECTED BY THE DISTRICT ENGINEER & OWNER.
6. SPECIFIED COMPACTION REQUIREMENTS ARE DISTRICT MINIMUMS AND IN THE EVENT OF CONFLICTS, THE MORE RESTRICTIVE REQUIREMENT SHALL PREVAIL.
7. TRENCH PATCH REQUIREMENTS ARE SPECIFIED AT STANDARD DETAIL ST-4.
8. BALL & FLUSH, AIR TEST, MANDREL TEST, AND TV INSPECTION REQUIRED PER STANDARD SPECIFICATIONS. SEWER SHALL BE TESTED AFTER JOINT TRENCH IS INSTALLED AND BACKFILLED.
9. THIS DETAIL SHALL FULLY COMPLY WITH STANDARDS W-35 AND W-36 AND IS NOT INTENDED TO BE USED AS A MITIGATIVE MEASURE.
10. THIS DETAIL MAY ONLY BE USED WHEN WRITTEN APPROVAL IS GRANTED BY THE DISTRICT ENGINEER AND STATE WATER RESOURCES CONTROL DIVISION OF DRINKING WATER (559) 447-3300.



**ROOT CREEK WATER DISTRICT
STANDARD DETAIL**

PREPARED BY: STEPHEN GRISEZ
Stephen Grisez
NICK BRUNO, RCWD PRESIDENT

**SEWER SAND PIPE BEDDING &
CEMENT BACKFILL**

SCALE: NOT TO SCALE

DATE ADOPTED: 8-12-2019

S-2

SHEET 2 OF 13

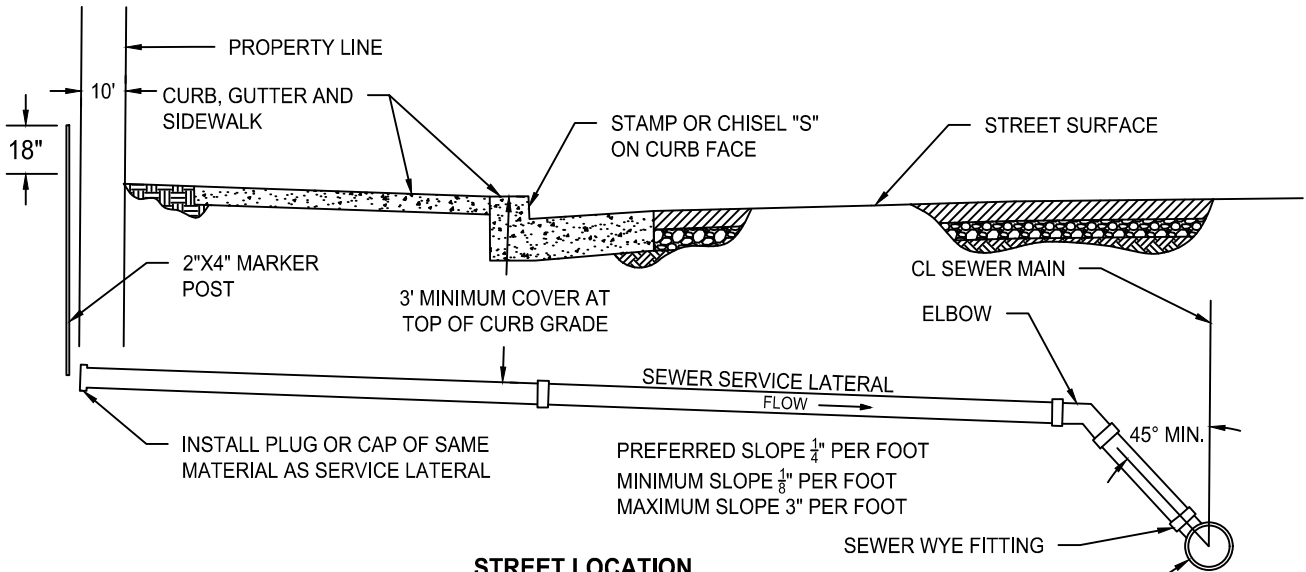

STREET LOCATION
NOT TO SCALE

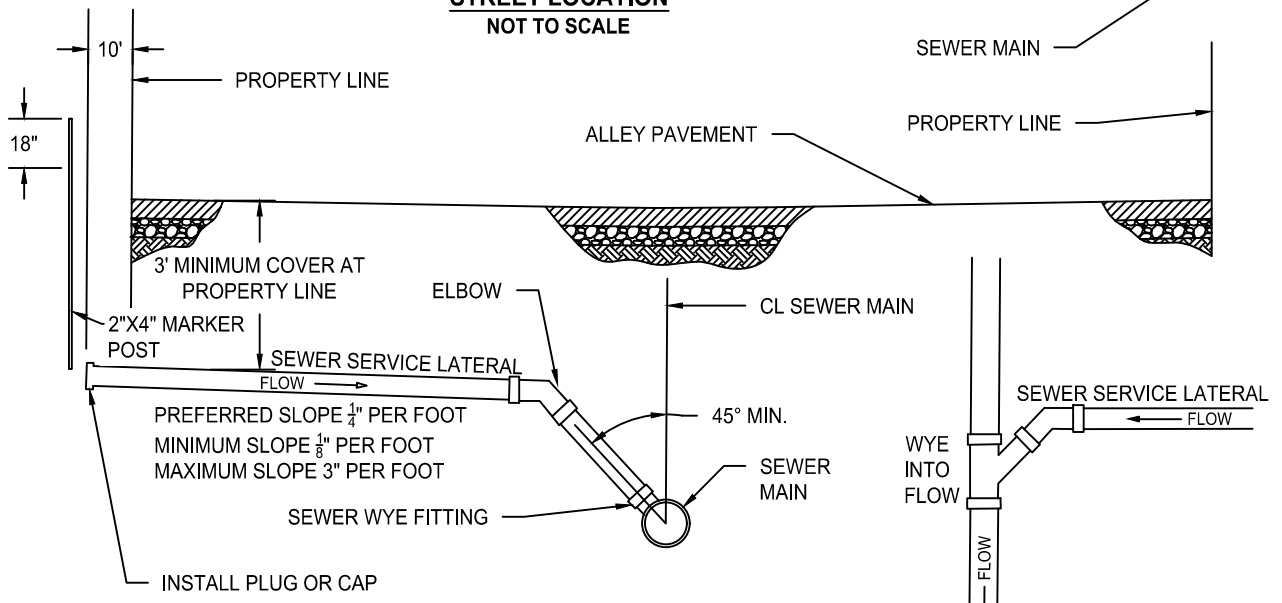

ALLEY LOCATION
NOT TO SCALE

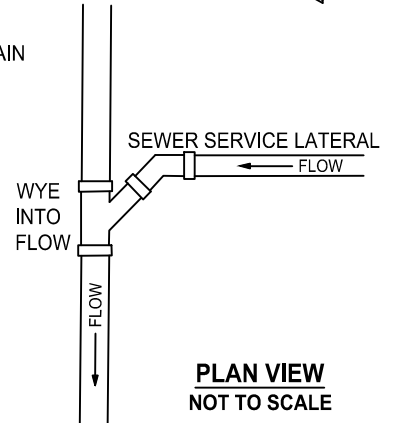

PLAN VIEW
NOT TO SCALE

NOTES:

1. GRAVITY SEWER PIPE & FITTINGS SHALL BE PVC, SDR-35 WITH INTEGRAL RUBBER GASKET JOINTS.
2. SERVICE INSTALLATION AT NEW PIPE SHALL BE CONSTRUCTED PER STANDARD DETAIL S-4 SERVICE INSTALLATION AT NEW PIPE.
3. SERVICE INSTALLATION AT EXISTING PIPE SHALL BE CONSTRUCTED PER STANDARD DETAIL S-4 SERVICE INSTALLATION AT EXISTING PIPE.
4. ALL SERVICES SHALL BE INSTALLED 10' BEYOND THE PROPERTY LINE.
5. ALL SERVICES SHALL EXTEND BEYOND JOINT TRENCH AND BE TESTED UPON COMPLETION OF JOINT TRENCH UTILITIES.
6. ALL SERVICE LOCATIONS STAMP OR CHISEL "S" ON THE FACE OF THE CURB.
7. WOOD 2"x4" MARKER POSTS PAINTED GREEN SHALL BE INSTALLED AT ALL SEWER SERVICES
8. SEWER SERVICES LARGER THAN 4" SHALL BE APPROVED BY DISTRICT ENGINEER ON A CASE BY CASE BASIS.
9. PIPE ZONE WASHED SAND, CAUTION TAPE, AND APPLICABLE TESTING PER STANDARD S-1.



**ROOT CREEK WATER DISTRICT
STANDARD DETAIL**

4 IN SEWER SERVICES

PREPARED BY: STEPHEN GRISEZ
Stephen Grisez
NICK BRUNO, RCWD PRESIDENT

SCALE: NOT TO SCALE
DATE ADOPTED: 8-12-2019

S-3
SHEET 3 OF 13

WYE WITH RUBBER GASKET JOINTS TO BE INSTALLED AT TIME OF NEW SEWER MAIN INSTALLATION

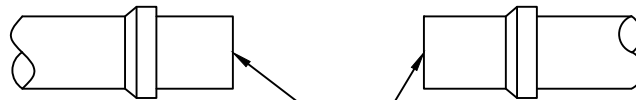
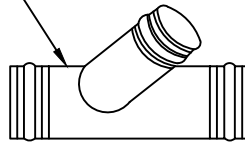

SEWER MAIN MACHINE CUT FOR INSERT

SERVICE INSTALLATION AT NEW PIPE

USE WYE GASKET TO TRACE SIZE AND SHAPE OF OPENING ONTO PIPE. REMOVE ALL BURRS FROM OPENING.

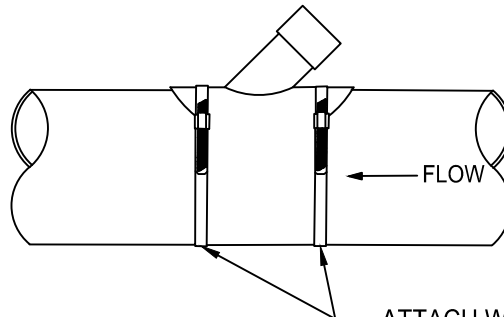
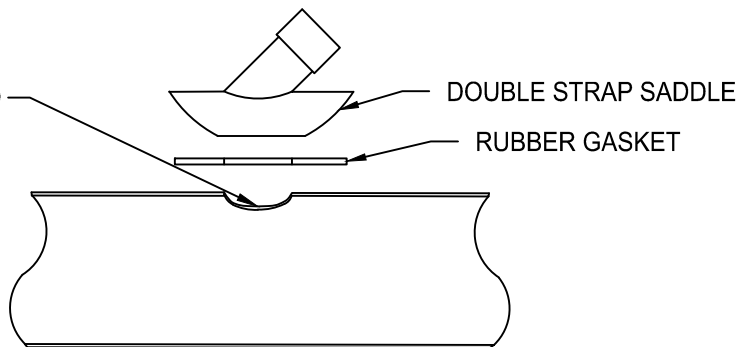

ATTACH WYE SADDLE WITH 2 STAINLESS STEEL BANDS PER MANUFACTURERS SPECIFICATIONS.

SERVICE INSTALLATION AT AN EXISTING PIPE

NOTES:

1. GRAVITY SEWER PIPE & FITTINGS SHALL BE PVC, SDR-35 WITH INTEGRAL RUBBER GASKET JOINTS.
2. SERVICES LARGER THAN 6 INCHES IN DIAMETER REQUIRE A MANHOLE AT POINT OF CONNECTION.
3. EXISTING SERVICE INSTALLATION TO PIPE SHALL BE BY MEANS OF AN APPROVED SADDLE AND MACHINE CORE. NO OTHER METHODS WILL BE ALLOWED



ROOT CREEK WATER DISTRICT
STANDARD DETAIL

SEWER SERVICE CONNECTIONS

PREPARED BY: STEPHEN GRISEZ

SCALE: NOT TO SCALE

NICK BRUNO, RCWD PRESIDENT

DATE ADOPTED: 8-12-2019

S-4

SHEET 4 OF 13

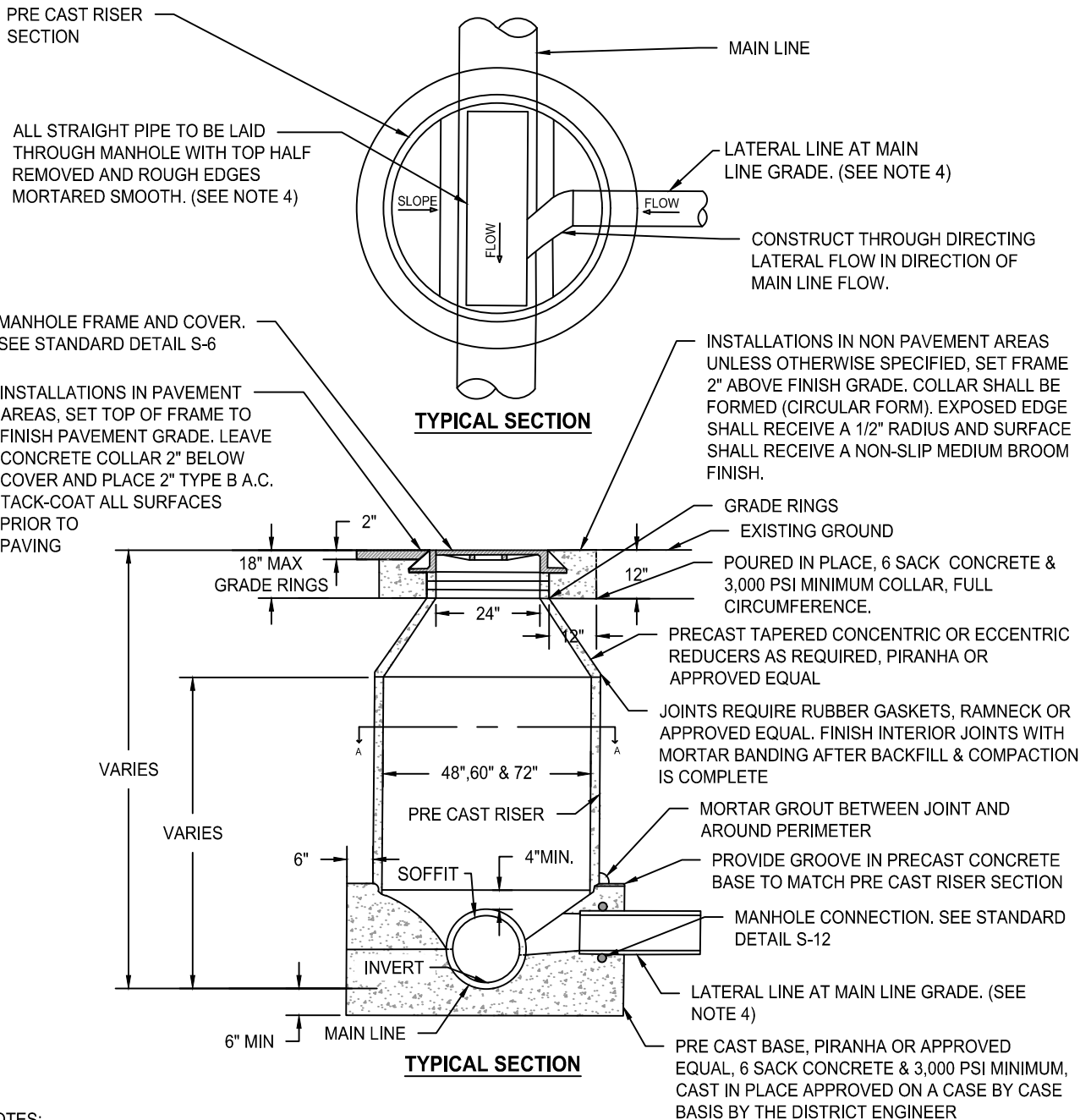

NOTES:

1. SEWER MANHOLE DIAMETER AND DEPTH SHALL BE SPECIFIED ON PLANS.
2. PRECAST SHAFT PIPE, GRADE RINGS AND TAPERED SECTION SHALL BE CONSTRUCTED IN ACCORDANCE WITH A.S.T.M. C-478, TYPE II CEMENT.
3. WHEN AN ECCENTRIC TAPERED SECTION IS SPECIFIED, IT SHALL FIRST BE ROTATED SO IT DOES NOT ALIGN WITH INLET AND OUTLET PIPES AND THEN TO THE EXTENT POSSIBLE IT SHALL BE ROTATED SO IT DOES NOT ALIGN WITH VEHICLE TIRE TRACKS.
4. FOR MANHOLES WITH A DROP OF .10', A FLOW THROUGH ALONG A SMOOTH RADIUS THROUGH THE CONCRETE MANHOLE BASE SHALL BE CONSTRUCTED TO FORM A UNIFORM FLOW SECTION OF THE SAME SHAPE AND SIZE OF THE PIPE BELOW THE SPRING LINE.
5. ALL MANHOLES GREATER THAN 7' ULTIMATE DEPTH REQUIRE ECCENTRIC CONES AND PVC STEPS.
6. ALL MANHOLES GREATER THAN 20' ULTIMATE DEPTH SHALL BE INCREASED FROM 48" DIAMETER TO 60" DIAMETER.
7. ALL COLLECTOR MANHOLES SHALL BE EPOXY LINED.
8. IF THE REQUIRED STRUCTURE EXCEEDS THE LARGEST DIMENSION SPECIFIED BY THE ROOT CREEK WATER DISTRICT STANDARD DETAIL, THE MANHOLE BASE MAY BE CAST-IN-PLACE, SUBJECT TO RCWD APPROVAL.

	ROOT CREEK WATER DISTRICT STANDARD DETAIL		48 IN, 60 IN, 72 IN SEWER MANHOLE	
	PREPARED BY: STEPHEN GRISEZ <i>Stephen Grisez</i>		SCALE: NOT TO SCALE	
	NICK BRUNO, RCWD PRESIDENT		DATE ADOPTED: 12-8-2025	
			S-5 SHEET 5 OF 13	

NOTES:

1. ALL MATING CONTACT SURFACES ON ON THE FRAME AND COVER SHALL BE MACHINED.
2. IDENTIFY ALL MANHOLE COVERS "SEWER", "SEWER SYSTEM", OR "SANITARY SEWER SYSTEM" RESPECTIVELY AS SHOWN.
3. FRAME AND COVER SHALL BE FULL H-20 RATED
4. SEWER MANHOLE COVERS TO BE FITTED WITH MANPANS.

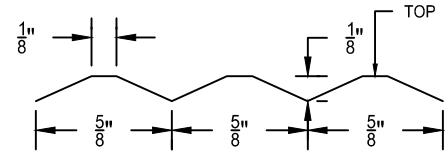

DETAIL WAFFLE PATTERN

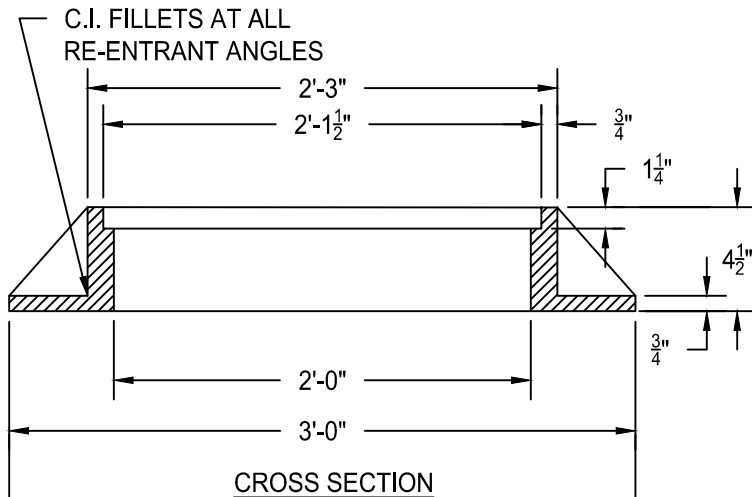

CROSS SECTION

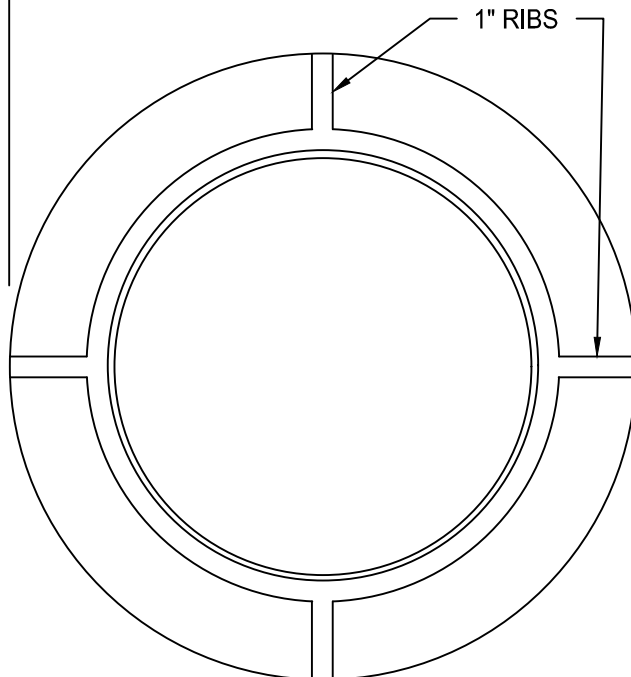

**PLAN
MANHOLE FRAME**

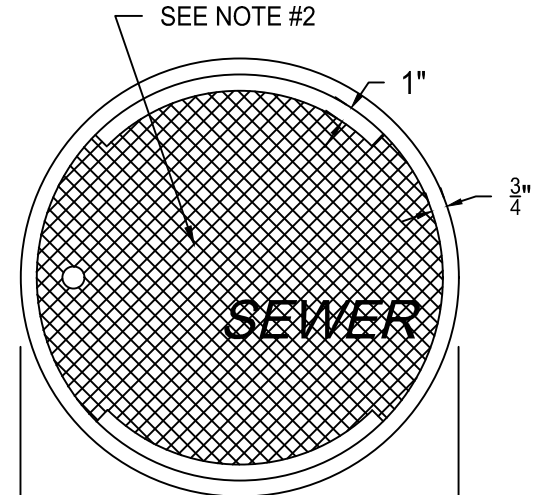

TOP

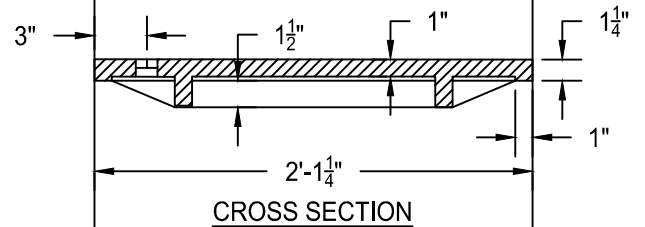

CROSS SECTION

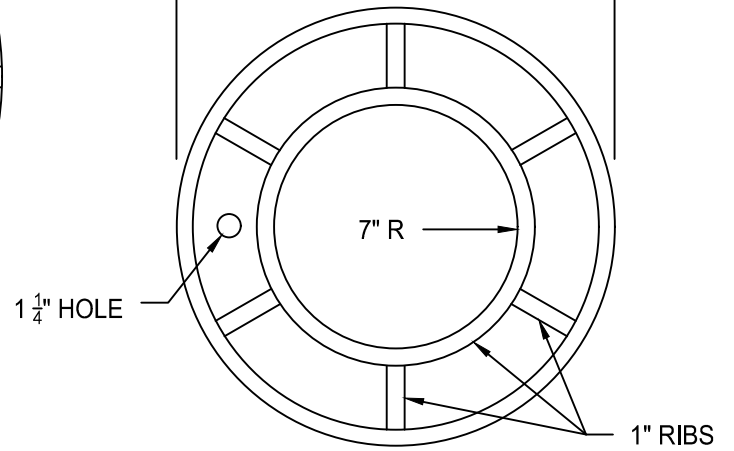

**BOTTOM
MANHOLE COVER**



**ROOT CREEK WATER DISTRICT
STANDARD DETAIL**

PREPARED BY: STEPHEN GRISEZ
Stephen Grisez
NICK BRUNO, RCWD PRESIDENT

**SEWER CAST IRON MANHOLE FRAME
AND COVER**

SCALE: NOT TO SCALE

DATE ADOPTED: 12-9-2019

S-6

SHEET 6 OF 13

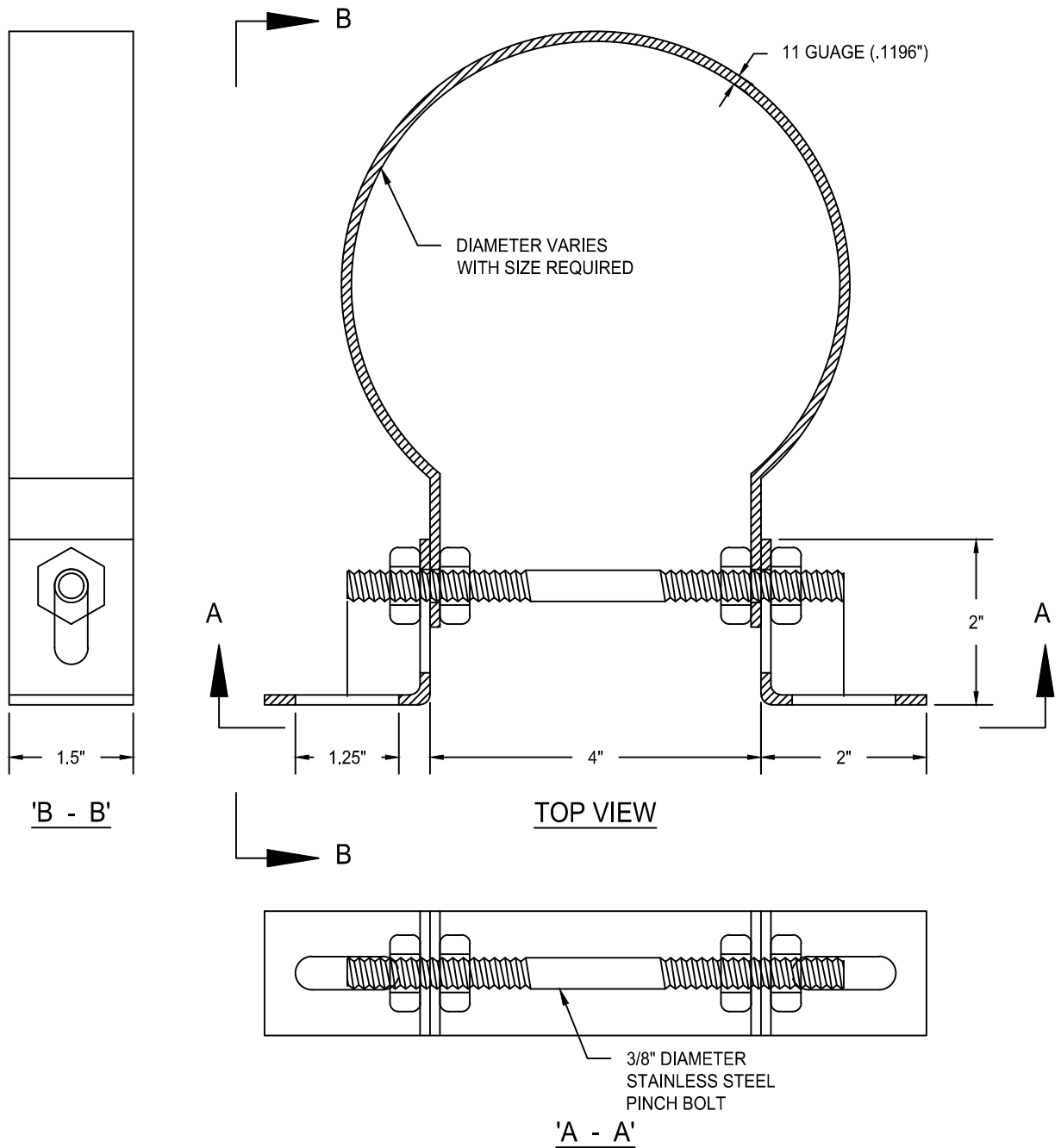

STAINLESS STEEL ADJUSTABLE CLAMPING BRACKET AS MANUFACTURED BY:

RELINER-DURAN, INC.
 53 MT. ARCHER RD.
 LYME, CT 06371
 (860)434-0277 FAX: (860)434-3195
 OR APPROVAL EQUAL

SPECIFICATIONS:

- 1) CLAMP AND BRACKETS IS TYPE 304 STAINLESS STEEL, 11 GAUGE (.1196").
- 2) 3/8" Ø PINCH BOLT AND NUTS IS TYPE 18-8 STAINLESS STEEL.



ROOT CREEK WATER DISTRICT
 STANDARD DETAIL

PREPARED BY: STEPHEN GRISEZ
Stephen Grisez
 NICK BRUNO, RCWD PRESIDENT

STAINLESS STEEL ADJUSTABLE CLAMPING
 BRACKETS

SCALE: NOT TO SCALE

DATE ADOPTED: 8-12-2019

S-7B

SHEET 8 OF 13

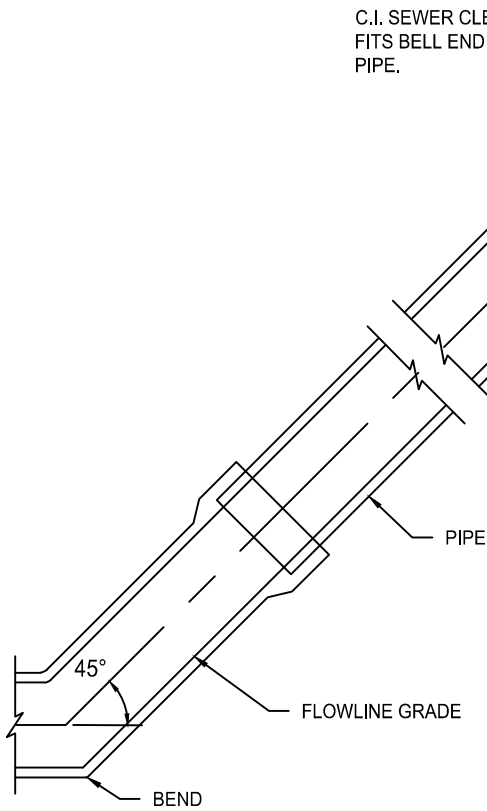
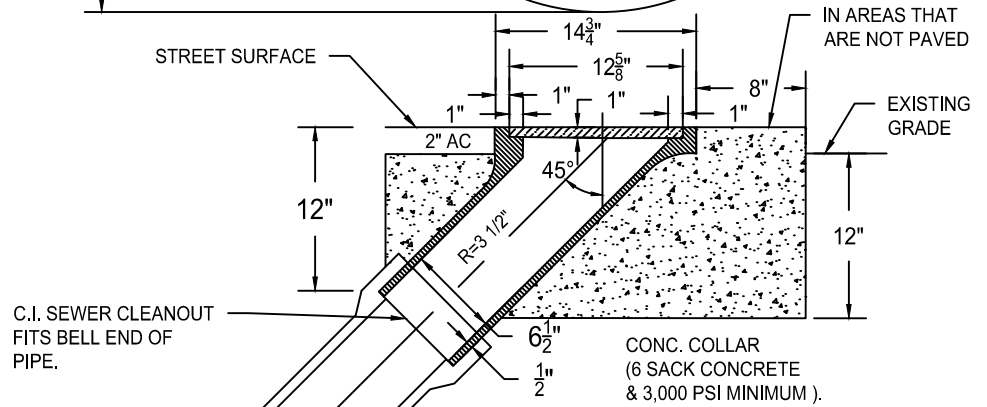
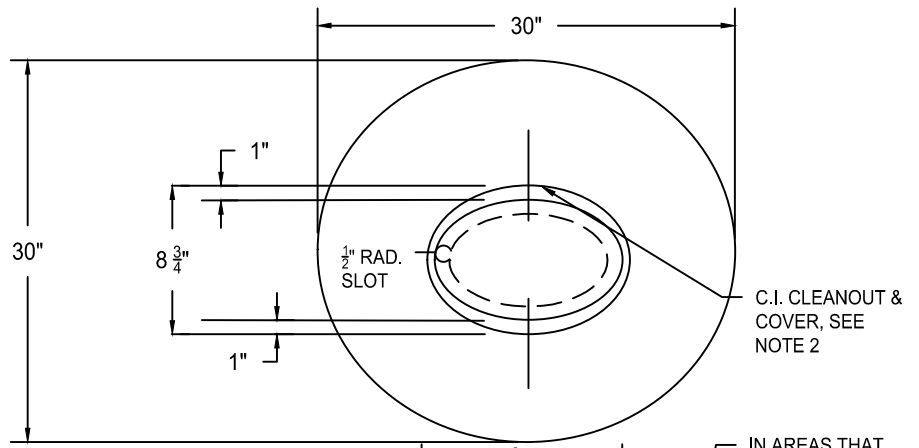

NOTES:

1. GRAVITY SEWER PIPE & FITTINGS SHALL BE PVC , SDR-35 WITH INTEGRAL RUBBER GASKET JOINTS.
2. CLEANOUT PIPE & FITTINGS SHALL BE SAME SIZE AS MAIN PIPE.
3. IDENTIFY ALL CLEANOUT COVERS "SEWER", "SEWER SYSTEM", OR "SANITARY SEWER SYSTEM".
4. INSTALLATIONS IN NON-PAVED AREAS:
 - A. UNLESS OTHERWISE SPECIFIED, SET FRAME 2" ABOVE FINISH GRADE.
 - B. COLLAR SHALL BE FORMED (CIRCULAR FORM).
 - C. EXPOSED EDGES SHALL RECEIVE 1/2" RADIUS AND SURFACE SHALL RECEIVE A NON-SLIP BROOM FINISH.



**ROOT CREEK WATER DISTRICT
STANDARD DETAIL**

PREPARED BY: STEPHEN GRISEZ
NICK BRUNO, RCWD PRESIDENT

4 IN, 6 IN & 8 IN SEWER CLEANOUT

SCALE: NOT TO SCALE

DATE ADOPTED: 8-12-2019

S-8

SHEET 9 OF 13

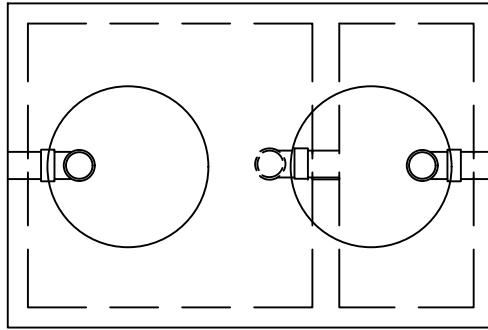

TOP VIEW
(COVER AND RINGS REMOVED)

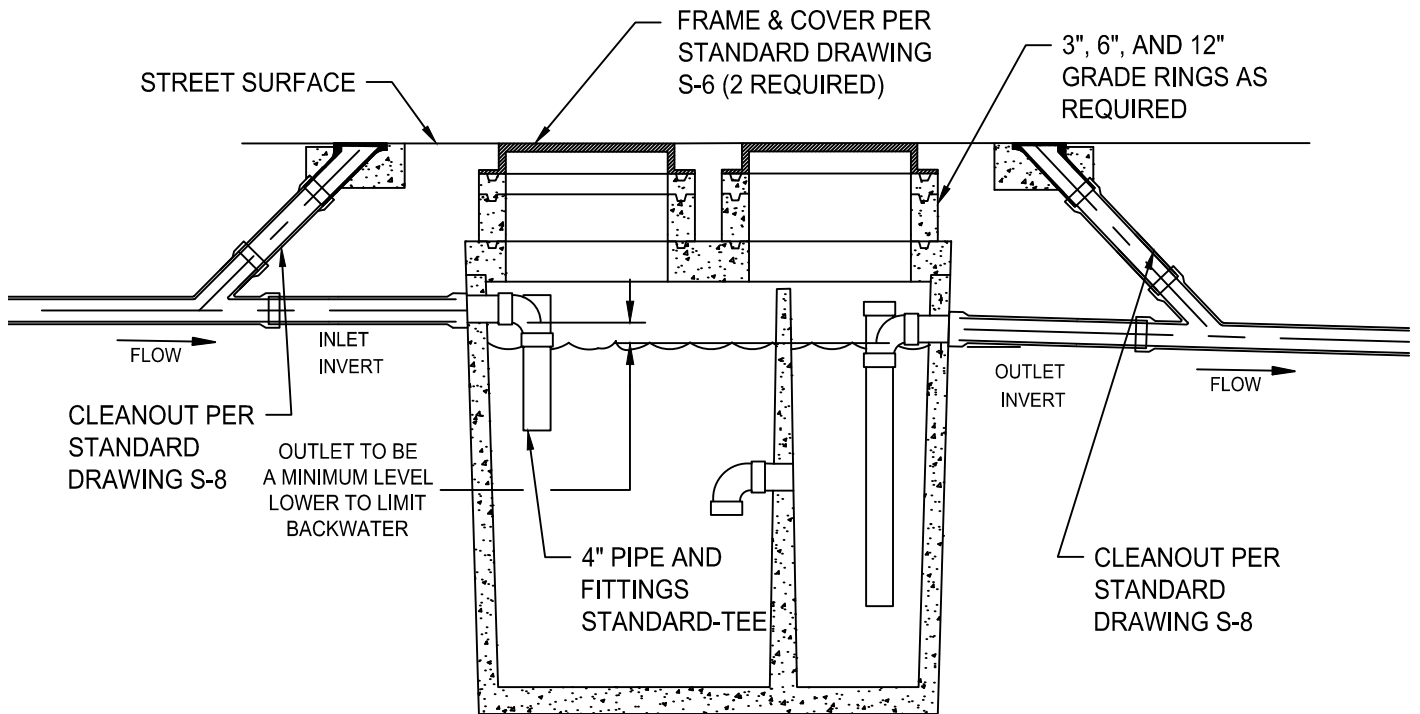

SIDE SECTION VIEW

NOTES:

1. PROPER SIZING TO BE DETERMINED BY CALCULATION, SUBJECT TO APPROVAL OF DISTRICT ENGINEER.
2. MINIMUM ALLOWABLE SIZE SHALL BE 500 GALLONS
3. RESPONSIBILITY FOR CLEANING AND MAINTENANCE BELONGS TO PROPERTY OWNER.
4. SAND & GREASE INTERCEPTOR SHALL BE JENSEN OR APPROVED EQUAL.
5. ALL CONCRETE SHALL BE 6 SACK CONCRETE & 3,000 PSI MINIMUM
6. DESIGN LOAD: H-20 TRAFFIC WITH DRY SOIL CONDITIONS (WATER LEVEL BELOW TANK) AND 1'-6" EARTH COVER.
7. SUITABLE SUB-BASED BEDDED WITH GRANULAR MATERIAL SHALL BE PREPARED TO HANDLE ANTICIPATED LOADS.



ROOT CREEK WATER DISTRICT
STANDARD DETAIL

PREPARED BY: STEPHEN GRISEZ
Stephen Grisez
NICK BRUNO, RCWD PRESIDENT

SEWER SAND AND GREASES INTERCEPTOR

SCALE: NOT TO SCALE

DATE ADOPTED: 8-12-2019

S-9

SHEET 10 OF 13

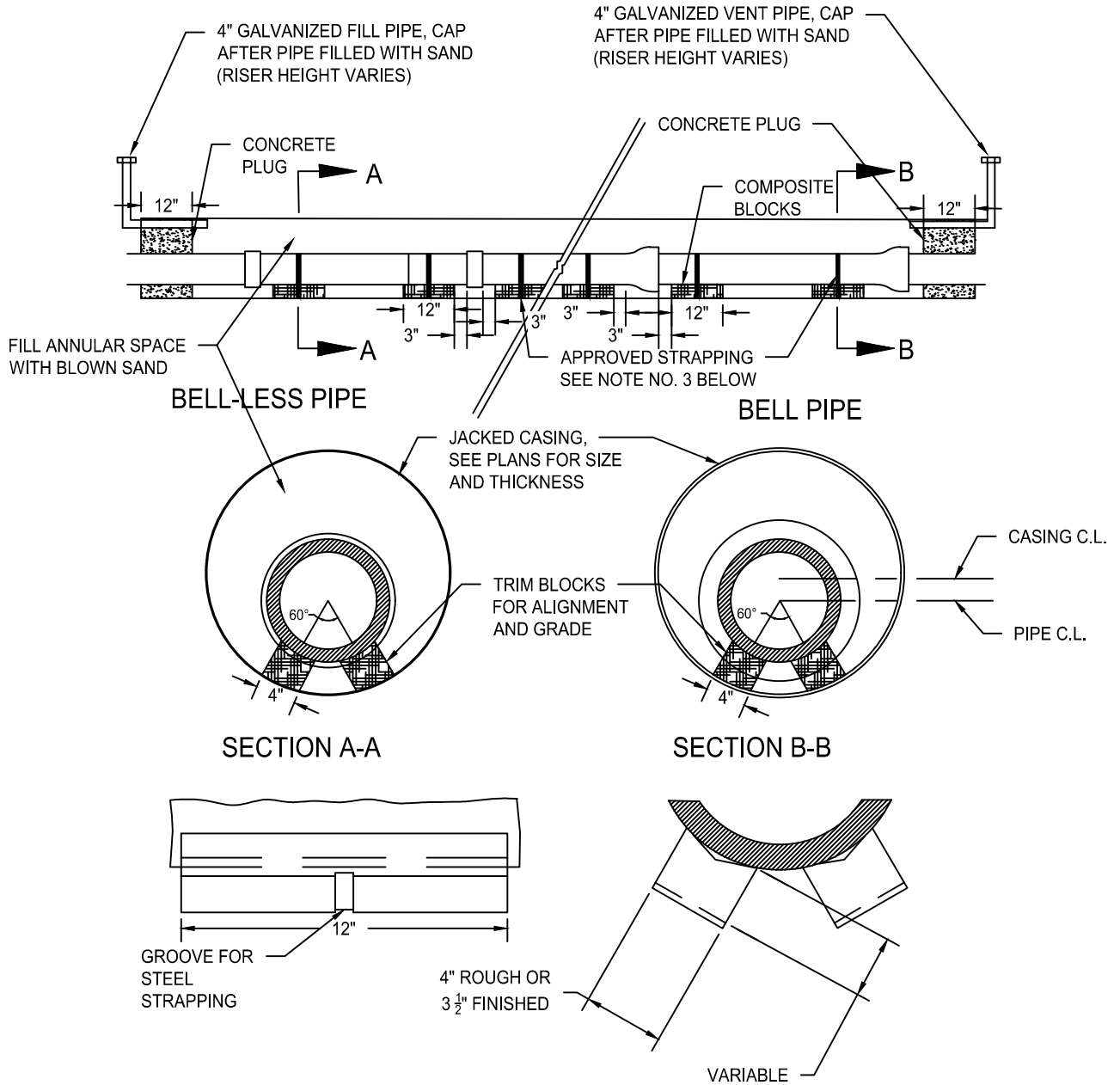

NOTES:

1. WHEN JACKING CASING, GRADE SHALL BE SET SO PIPE CENTER LINE IS LOWER THAN CASING CENTERLINE AS SHOWN IN SECTION B-B.
2. CASING SHOULD HAVE A MINIMUM OF 6" CLEAR WHEN USING TRIM BLOCKS.
3. COMPOSITE BLOCKS SHALL BE USED.
4. COMPOSITE BLOCKS SHALL VEED TO FIT CONTOUR OF PIPE.
5. COMPOSITE BLOCKS SHALL BE STRAPPED TO THE PIPE WITH STEEL STRAPPING OR APPROVED WIRE BANDS.
6. PLUG ENDS OF CASING WITH 12 INCHES MINIMUM OF CONCRETE.
7. CONCRETE SHALL BE 6 SACK CONCRETE & 3,000 PSI MINIMUM.
8. MANUFACTURED SKIDS ARE ALSO ACCEPTABLE TO AND SHALL BE INSTALLED NEAR SPIGOT, MID-POINT, AND BELL (3 PER JOINT).



**ROOT CREEK WATER DISTRICT
STANDARD DETAIL**

PREPARED BY: STEPHEN GRISEZ
Steph Grisez
NICK BRUNO, RCWD PRESIDENT

**SEWER PIPE IN JACKED
STEEL CASING**

SCALE: NOT TO SCALE

DATE ADOPTED: 8-12-2019

S-10

SHEET 11 OF 13

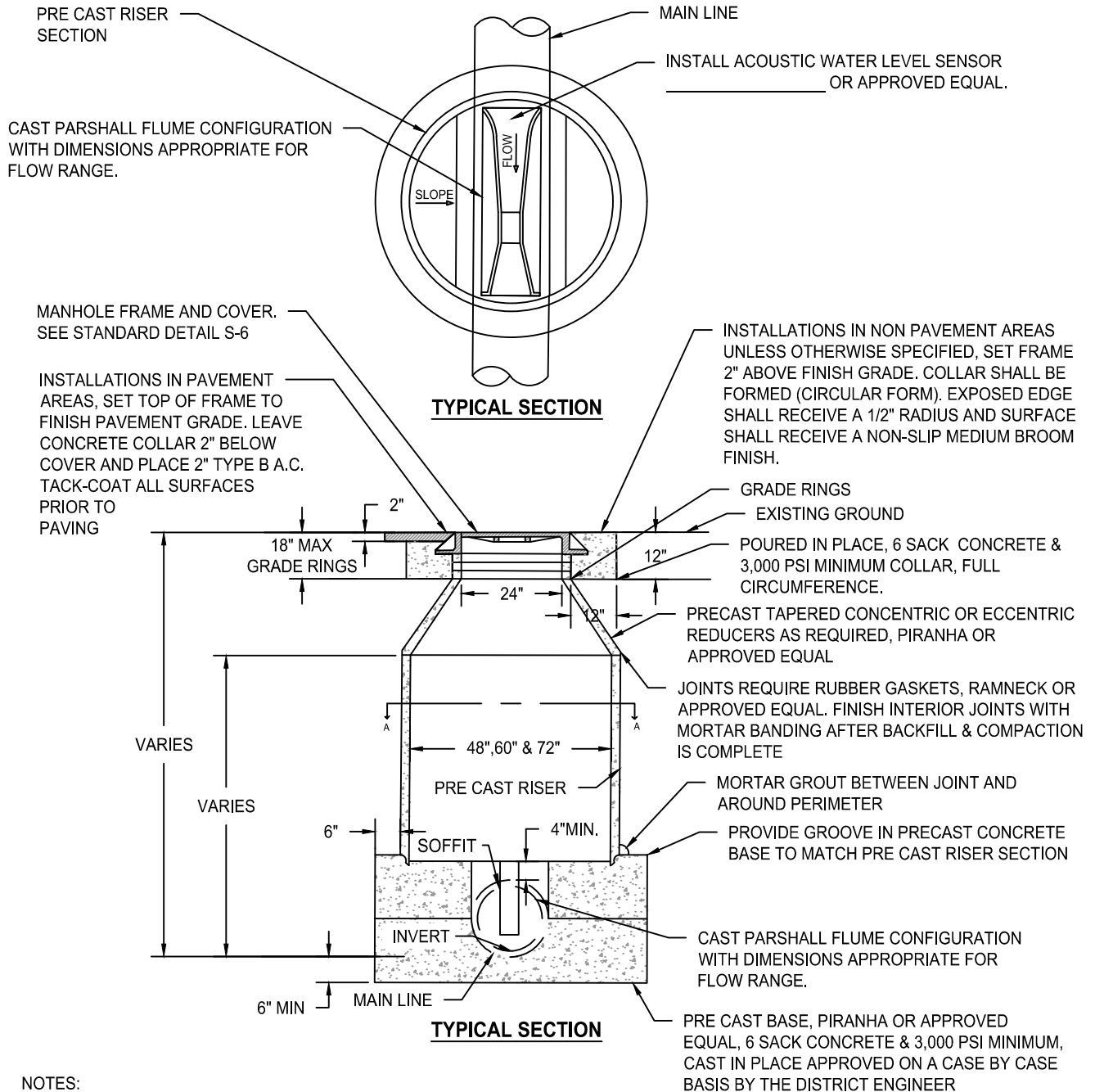

NOTES:

1. SEWER MANHOLE DIAMETER AND DEPTH SHALL BE SPECIFIED ON PLANS.
2. PRECAST SHAFT PIPE, GRADE RINGS AND TAPERED SECTION SHALL BE CONSTRUCTED IN ACCORDANCE WITH A.S.T.M. C-478, TYPE II CEMENT.
3. WHEN AN ECCENTRIC TAPERED SECTION IS SPECIFIED, IT SHALL FIRST BE ROTATED SO IT DOES NOT ALIGN WITH INLET AND OUTLET PIPES AND THEN TO THE EXTENT POSSIBLE IT SHALL BE ROTATED SO IT DOES NOT ALIGN WITH VEHICLE TIRE TRACKS.
4. FOR MANHOLES WITH A DROP OF .10', A FLOW THROUGH ALONG A SMOOTH RADIUS THROUGH THE CONCRETE MANHOLE BASE SHALL BE CONSTRUCTED TO FORM A UNIFORM FLOW SECTION OF THE SAME SHAPE AND SIZE OF THE PIPE BELOW THE SPRING LINE.
5. ALL MANHOLES GREATER THAN 7' ULTIMATE DEPTH REQUIRE ECCENTRIC CONES AND PVC STEPS.
6. ALL MANHOLES GREATER THAN 20' ULTIMATE DEPTH SHALL BE INCREASED FROM 48" DIAMETER TO 60" DIAMETER.
7. ALL COLLECTOR MANHOLES SHALL BE EPOXY LINED.
8. IF THE REQUIRED STRUCTURE EXCEEDS THE LARGEST DIMENSION SPECIFIED BY THE ROOT CREEK WATER DISTRICT STANDARD DETAIL, THE MANHOLE BASE MAY BE CAST-IN-PLACE, SUBJECT TO RCWD APPROVAL.



**ROOT CREEK WATER DISTRICT
STANDARD DETAIL**

PREPARED BY: *Stephen Grisez*
STEPHEN GRISEZ
NICK BRUNO, RCWD PRESIDENT

METERING SEWER MANHOLE

SCALE: NOT TO SCALE

DATE ADOPTED: 12-8-2025

S-11

SHEET 12 OF 13

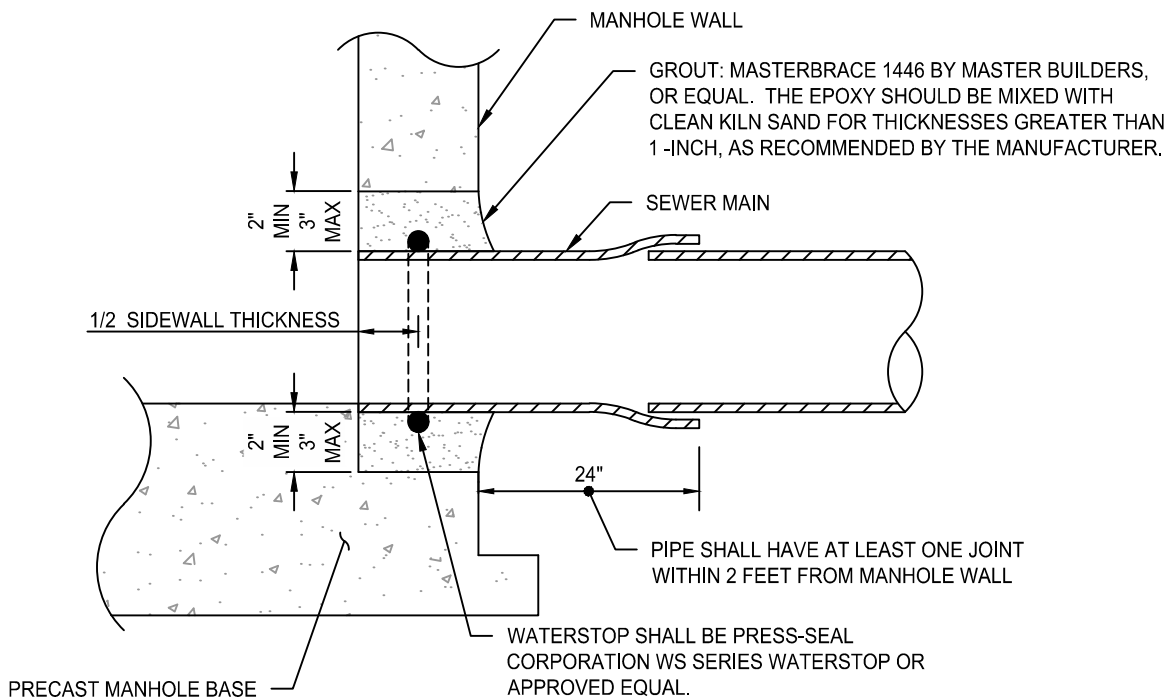

ROOT CREEK WATER DISTRICT
STANDARD DETAIL

MANHOLE PIPE CONNECTION

PREPARED BY: STEPHEN GRISEZ

SCALE: NOT TO SCALE

S-12

NICK BRUNO, RCWD PRESIDENT

DATE ADOPTED: 4-14-2025

SHEET 13 OF 13

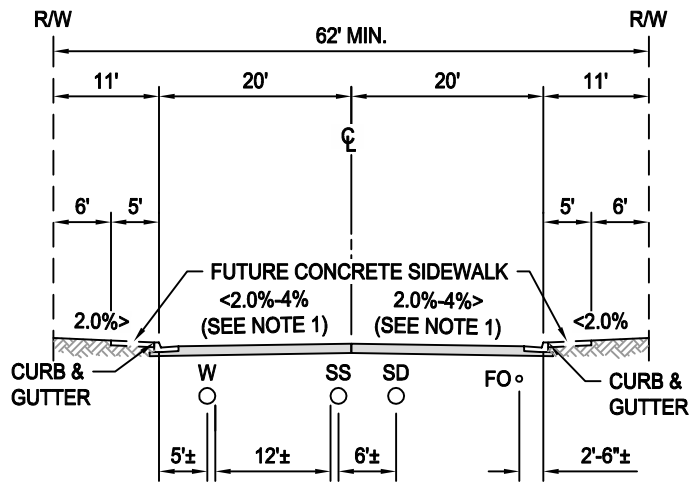

STREET

W WATER
 RW RECYCLED WATER
 SS SEWER

SD STORM DRAIN
 FO FIBER OPTIC

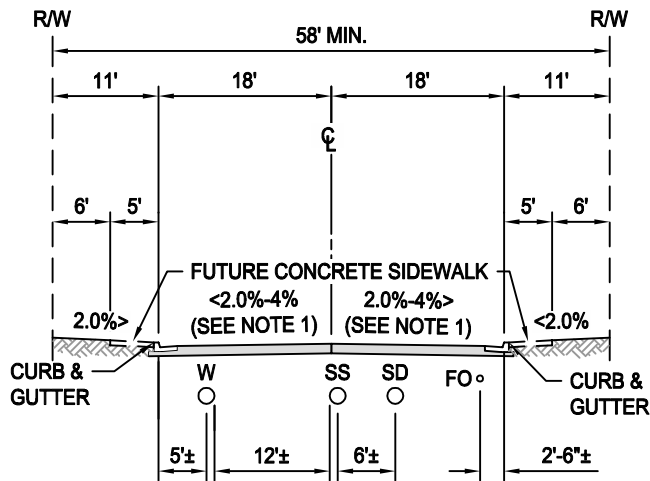

INTERIOR STREET

NOTES:

1. PAVEMENT CROSS-SLOPES ARE MINIMUM-MAXIMUM VALUES.
2. SEWER/WATER SPACING MUST COMPLY WITH STATE GUIDANCE.
3. CROSS SECTIONS ARE LOOKING WEST OR NORTH.
 THEREFORE, WATER SHALL BE ON THE SOUTH OR WEST SIDE OF THE ROAD.



**ROOT CREEK WATER DISTRICT
 STANDARD DETAIL**

PREPARED BY: STEPHEN GRISEZ
Stephen Grisez
 NICK BRUNO, RCWD PRESIDENT

**TWO LANE COLLECTOR & INDUSTRIAL
 STREET UTILITY LOCATIONS**

SCALE: NOT TO SCALE

DATE ADOPTED: 8-12-2019

ST-2

SHEET 2 OF 3

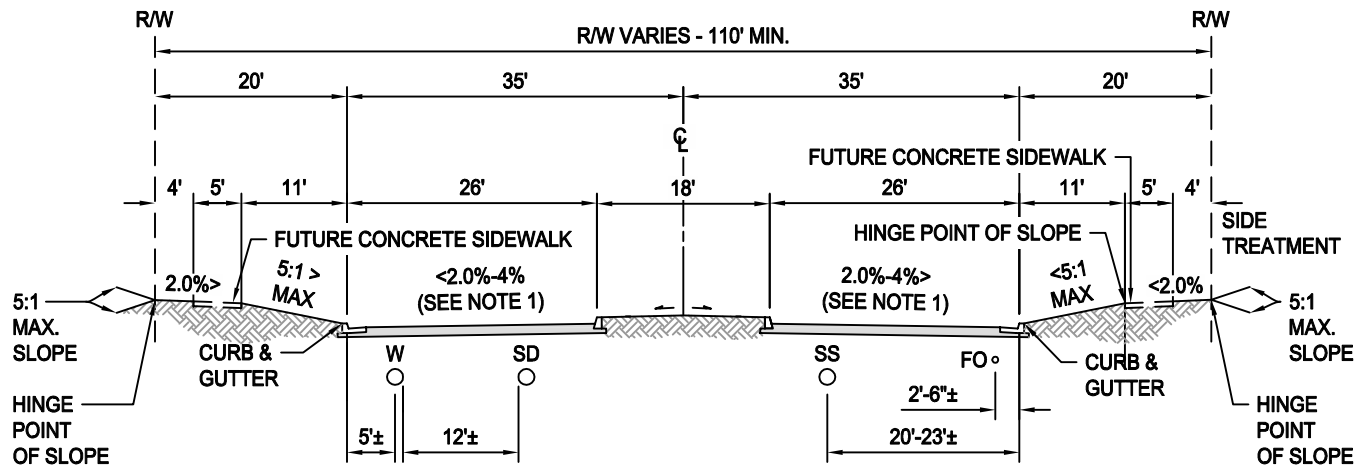

BOULEVARD

W WATER
 RW RECYCLED WATER
 SS SEWER

SD STORM DRAIN
 FO FIBER OPTIC

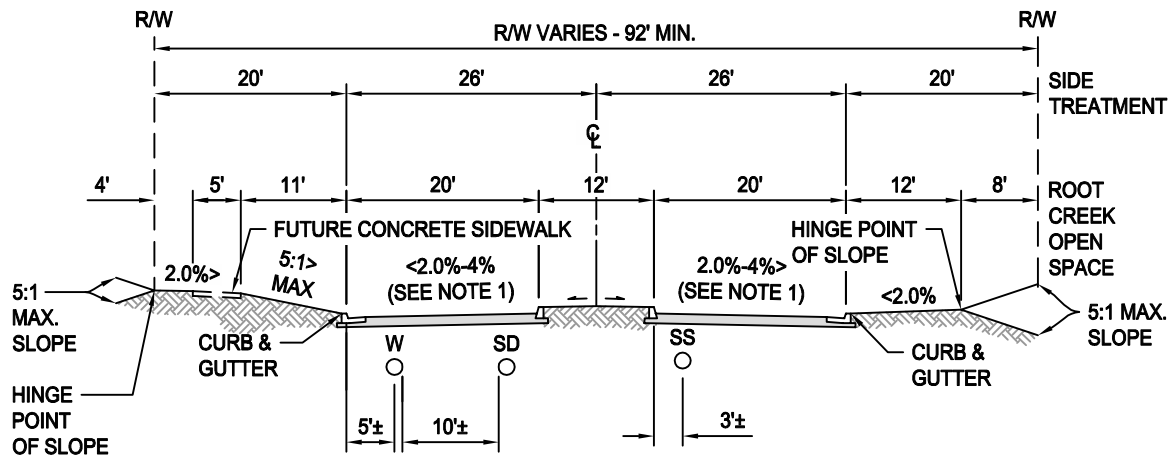

PARKWAY / AVENUE

NOTES:

1. PAVEMENT CROSS-SLOPES ARE MINIMUM-MAXIMUM VALUES.
2. SEWER/WATER SPACING MUST COMPLY WITH STATE GUIDANCE.
3. WATER SHALL BE ON THE SOUTH OR WEST SIDE OF THE ROAD.
 THEREFORE, WATER SHALL BE ON THE SOUTH OR WEST SIDE OF THE ROAD.



**ROOT CREEK WATER DISTRICT
 STANDARD DETAIL**

PREPARED BY: STEPHEN GRISEZ
 NICK BRUNO, RCWD PRESIDENT

**FOUR LANE MAJOR STREET UTILITY
 LOCATIONS**

SCALE: NOT TO SCALE

DATE ADOPTED: 8-12-2019

ST-3

SHEET 3 OF 3

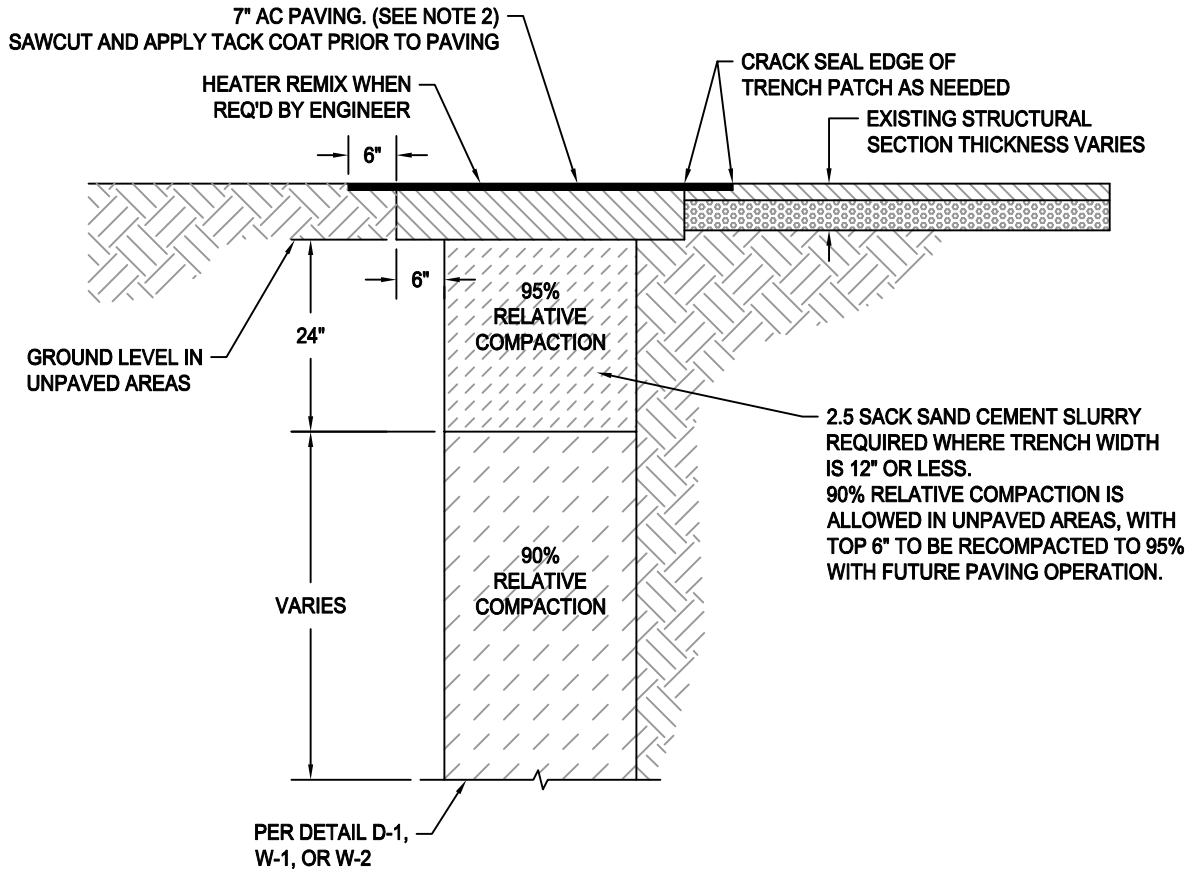

NOTES:

1. TEMPORARY TRENCH RESURFACING SHALL CONSIST OF A MINIMUM OF 4" COLD MIX AND SHALL BE REQUIRED WHENEVER THE STREET IS TEMPORARILY OPENED TO TRAFFIC. ALL TEMPORARY MATERIAL SHALL BE COMPLETELY REMOVED PRIOR TO FINAL PAVING.
2. PERMANENT TRENCH RESURFACING IN PAVED AREAS SHALL CONSIST OF 7" A.C. PAVING OR MATCH EXISTING PAVEMENT SECTION IF TRENCH IS WIDER THAN 6' UNLESS SPECIFIED OTHERWISE. EXISTING PAVEMENT EDGES SHALL BE SAWCUT AND APPLY TACK COAT PRIOR TO FINAL PAVING.
3. TRENCH RESURFACING STRUCTURAL SECTION IN OTHER THAN PERMANENTLY PAVED OR UNPAVED AREAS SHALL BE DETERMINED BY THE CITY ENGINEER.



**ROOT CREEK WATER DISTRICT
STANDARD DETAIL**

PREPARED BY: STEPHEN GRISEZ
Stephen Grisez
NICK BRUNO, RCWD PRESIDENT

TRENCH RESURFACING

SCALE: NOT TO SCALE

DATE ADOPTED: 8-12-2019

ST-4

SHEET 4 OF 3

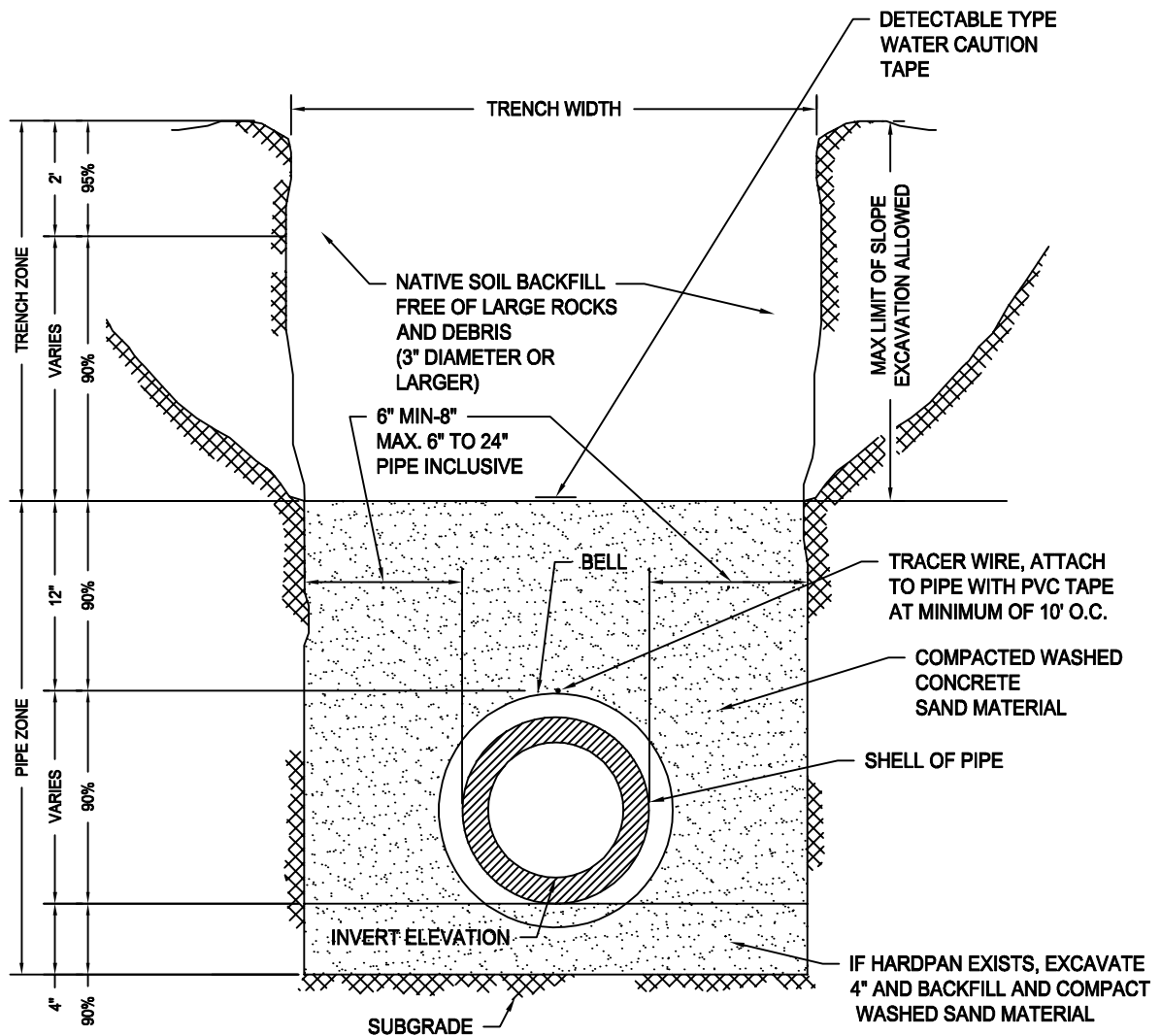

NOTES:

1. APPLICABLE FOR INSTALLATION WITH 3' OR GREATER MINIMUM COVER.
2. FOR COVER LESS THAN 3' SEE STANDARD DETAIL D-2
3. PRESSURE WATER PIPE SHALL BE MINIMUM CLASS 150 AND CONFORM TO ASTM C-900 MEETING DR-18 RATING. FITTINGS SHALL BE DUCTILE IRON WITH MEGALUG RESTRAINTS PER STANDARDS W-3, W-4, & W-5, WITH INTEGRAL RUBBER GASKET JOINTS.
4. PIPE ZONE MATERIAL SHALL BE WASHED CONCRETE SAND FREE OF SILT AND ORGANIC MATERIAL. PIPE ZONE SHALL INITIALLY BE FILLED TO SPRINGLINE OF PIPE, WATERED, AND HAUNCHES COMPACTED WITH A WACKER TYPE COMPACTOR 4" WIDE X 12" LONG SHOE PLATE.
5. COMPACTION TESTING OF ALL TRENCHES SHALL BE REQUIRED AS SPECIFIED IN STANDARD SPECIFICATIONS AND AS DIRECTED BY THE DISTRICT ENGINEER & OWNER.
6. SPECIFIED COMPACTION REQUIREMENTS ARE DISTRICT MINIMUMS AND IN THE EVENT OF CONFLICTS, THE MORE RESTRICTIVE REQUIREMENT SHALL PREVAIL.
7. TRENCH PATCH REQUIREMENTS ARE SPECIFIED AT STANDARD DETAIL ST-4.



**ROOT CREEK WATER DISTRICT
STANDARD DETAIL**

PREPARED BY: *Stephen Grisez*
STEPHEN GRISEZ
NICK BRUNO, RCWD PRESIDENT

**WATER SAND PIPE BEDDING &
TRENCH BACKFILL**

SCALE: NOT TO SCALE

DATE ADOPTED: 4-12-2021

W-1

SHEET 1 OF 39

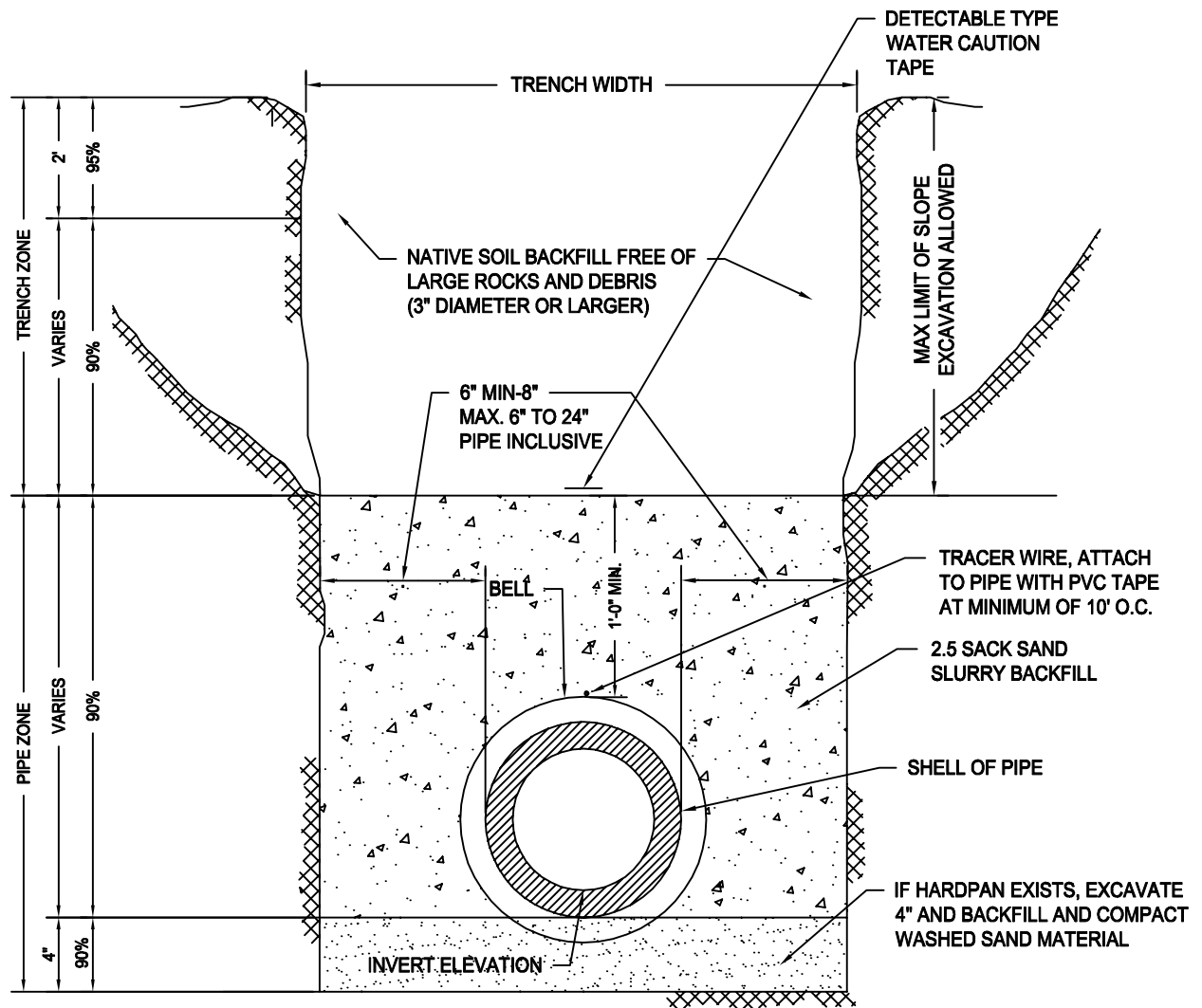

NOTES:

1. APPLICABLE FOR INSTALLATION WITH LESS THAN 3' MINIMUM COVER.
2. PRESSURE WATER PIPE SHALL BE MINIMUM CLASS 150 AND CONFORM TO ASTM C-900 MEETING DR-14 RATING. FITTINGS SHALL BE DUCTILE IRON WITH MEGALUG RESTRAINTS PER STANDARDS W-3, W-4, & W-5, WITH INTEGRAL RUBBER GASKET JOINTS.
3. BEDDING MATERIAL SHALL BE WASHED CONCRETE SAND FREE OF SILT AND ORGANIC MATERIAL.
4. PIPE ZONE MATERIAL SHALL BE 2.5 SACK CEMENT SAND SLURRY.
5. COMPACTION TESTING OF ALL TRENCHES SHALL BE REQUIRED AS SPECIFIED IN STANDARD SPECIFICATIONS AND AS DIRECTED BY THE DISTRICT ENGINEER & OWNER.
6. SPECIFIED COMPACTION REQUIREMENTS ARE DISTRICT MINIMUMS AND IN THE EVENT OF CONFLICTS, THE MORE RESTRICTIVE REQUIREMENT SHALL PREVAIL.
7. TRENCH PATCH REQUIREMENTS ARE SPECIFIED AT STANDARD DETAIL ST-4.
8. PRESSURE WATER PIPE SHALL REQUIRE HYDROSTATIC TESTING PER STANDARD SPECIFICATIONS.
9. THIS DETAIL SHALL FULLY COMPLY WITH STANDARDS W-35 AND W-36 AND IS NOT INTENDED TO BE USED AS A MITIGATION MEASURE.
10. THIS DETAIL MAY ONLY BE USED WHEN WRITTEN APPROVAL IS GRANTED BY THE DISTRICT ENGINEER AND STATE WATER RESOURCES CONTROL BOARD DIVISION OF DRINKING WATER (559) 447-3300.



**ROOT CREEK WATER DISTRICT
STANDARD DETAIL**

PREPARED BY: STEPHEN GRISEZ
NICK BRUNO, RCWD PRESIDENT

**WATER SAND PIPE BEDDING & CEMENT
SAND SLURRY TRENCH BACKFILL**

SCALE: NOT TO SCALE

DATE ADOPTED: 9-14-2020

W-2

SHEET 2 OF 39

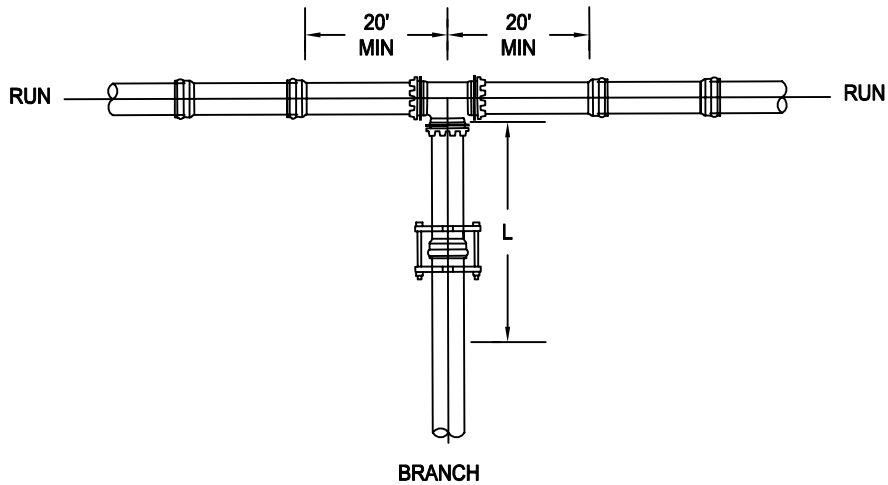

		RUN SIZE									
		4	6	8	10	12	14	16	18	20	24
BRANCH SIZE	4	*	*	*	*	*	*	*	*	*	*
	6	*	*	*	*	*	*	*	*	*	*
	8	38	*	*	*	*	*	*	*	*	*
	10	76	47	19	*	*	*	*	*	*	*
	12	111	86	63	36	13	*	*	*	*	*
	14	144	123	102	79	57	36	13	*	*	*
	16	170	152	134	115	95	78	54	31	14	*
	18	196	180	165	147	130	115	94	74	54	16
	20	222	208	194	178	163	149	130	74	95	57
	24	270	258	247	234	222	210	195	180	166	135

* -FOR THIS CONDITION
NEED ONLY RESTRAIN THE
BRANCH OUTLET OF THE TEE.

RESTRAINED LENGTHS, "L" (IN FEET)

NOTES:

1. RESTRAIN THE TWO MECHANICAL JOINTS ON THE RUN SIDES OF THE TEE. WHEN LESS THAN A FULL 20' LENGTH OF PIPE IS INSTALLED ON EACH SIDE OF THE RUN.
2. ALL JOINTS WITHIN THE LENGTH "L" ON THE BRANCH MUST BE RESTRAINED. USE RETAINER GLAND AT MECHANICAL JOINTS AND HARNESS ON PUSH-ON PIPE.
3. RESTRAINED JOINT ADAPTERS SHALL BE EBAA MEGALUG WITH MEGA-BOND COATING OR APPROVED EQUAL.
4. BELL HARNESS SHALL BE MEGALUG BELL RESTRAINT HARNESSES WITH MEGA-BOND COATING OR APPROVED EQUAL.
5. ALL NUTS, BOLTS, MECHANICAL JOINTS, AND BELL HARNESS RESTRAINTS SHALL INCLUDE 304 OR 316 STAINLESS STEEL HARDWARE, BE COATED WITH AN ANTI-SEIZE COMPOUND, AND BE WRAPPED IN VISQUEEN PLASTIC SHEETING AND SECURED IN PLACE WITH PVC TAPE.
6. ALL WATER SYSTEM MATERIALS THAT COME INTO CONTACT WITH POTABLE WATER SHALL BE ANSI/NSF STANDARD-61 CERTIFIED OR EQUIVALENT AND SHALL BE LEAD FREE.



**ROOT CREEK WATER DISTRICT
STANDARD DETAIL**

PVC PIPE TEE RESTRAINTS

PREPARED BY: STEPHEN GRISEZ
Steph Grisez
NICK BRUNO, RCWD PRESIDENT

SCALE: NOT TO SCALE

DATE ADOPTED: 8-12-2019

W-3

SHEET 3 OF 39

HORIZONTAL BEND

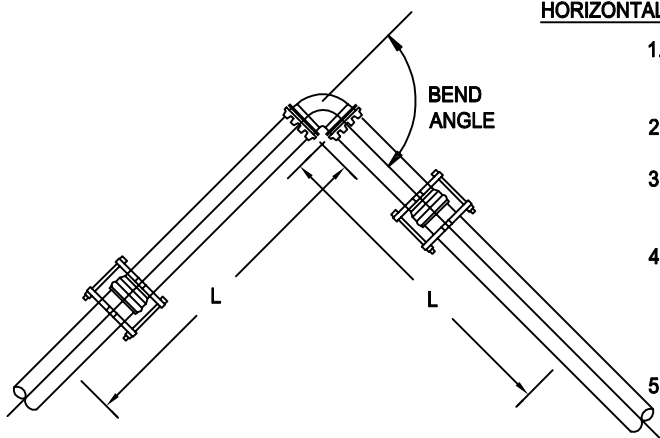

1. ALL JOINTS WITHIN LENGTH "L" MUST BE RESTRAINED. USE RETAINER GLAND AT MECHANICAL JOINTS AND HARNESS WITH PUSH-ON PIPE.
2. RESTRAINED JOINT ADAPTERS SHALL BE EBAA MEGALUG WITH MEGA-BOND COATING OR APPROVED EQUAL.
3. BELL HARNESS SHALL BE MEGALUG BELL RESTRAINT HARNESSES WITH MEGA-BOND COATING OR APPROVED EQUAL.
4. ALL NUTS,BOLTS,MECHANICAL JOINTS, AND BELL HARNESS RESTRAINTS SHALL INCLUDE 304 OR 316 STAINLESS STEEL HARDWARE, BE COATED WITH AN ANTI-SEIZE COMPOUND, AND BE WRAPPED IN VISQUEEN PLASTIC SHEETING AND SECURED IN PLACE WITH PVC TAPE.
5. ALL WATER SYSTEM MATERIALS THAT COME INTO CONTACT WITH POTABLE WATER SHALL BE ANSI/NSF STANDARD-61 CERTIFIED OR EQUIVALENT AND SHALL BE LEAD FREE.

		PIPE DIAMETER (INCHES)						
		4	6	8	10	12	14	16
BEND ANGLE	11.25	3	3	3	4	4	5	5
	22.5	3	5	7	7	9	10	11
	45	7	11	13	15	18	20	23
	90	17	24	31	37	43	49	55

RESTRAINED LENGTHS, "L" (IN FEET)

VERTICAL BEND

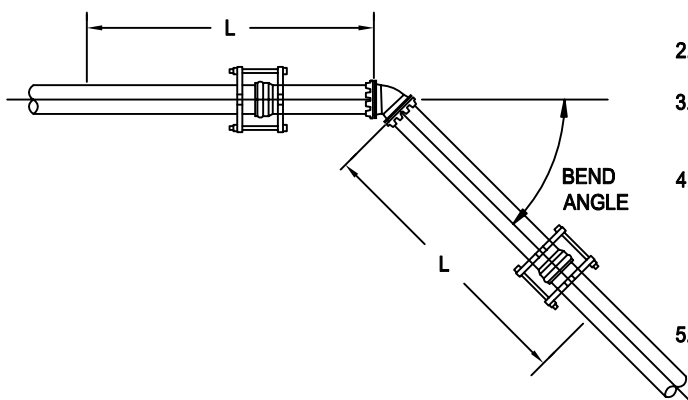

1. ALL JOINTS WITHIN LENGTH "L" MUST BE RESTRAINED. USE RETAINER GLAND AT MECHANICAL JOINTS AND HARNESS WITH PUSH-ON PIPE.
2. RESTRAINED JOINT ADAPTERS SHALL BE EBAA MEGALUG WITH MEGA-BOND COATING OR APPROVED EQUAL.
3. BELL HARNESS SHALL BE MEGALUG BELL RESTRAINT HARNESSES WITH MEGA-BOND COATING OR APPROVED EQUAL.
4. ALL NUTS,BOLTS,MECHANICAL JOINTS, AND BELL HARNESS RESTRAINTS SHALL INCLUDE 304 OR 316 STAINLESS STEEL HARDWARE, BE COATED WITH AN ANTI-SEIZE COMPOUND, AND BE WRAPPED IN VISQUEEN PLASTIC SHEETING AND SECURED IN PLACE WITH PVC TAPE.
5. ALL WATER SYSTEM MATERIALS THAT COME INTO CONTACT WITH POTABLE WATER SHALL BE ANSI/NSF STANDARD-61 CERTIFIED OR EQUIVALENT AND SHALL BE LEAD FREE.

		PIPE DIAMETER (INCHES)						
		4	6	8	10	12	14	16
BEND ANGLE	11.25	5	7	9	11	13	15	17
	22.5	11	15	19	23	27	31	35
	45	23	31	40	48	56	64	72

RESTRAINED LENGTHS, "L" (IN FEET)



**ROOT CREEK WATER DISTRICT
STANDARD DETAIL**

PREPARED BY: STEPHEN GRISEZ
Stephen Grisez
NICK BRUNO, RCWD PRESIDENT

PVC BEND RESTRAINTS

SCALE: NOT TO SCALE

DATE ADOPTED: 8-12-2019

W-4

SHEET 4 OF 37

DEAD END FOR PVC PIPE

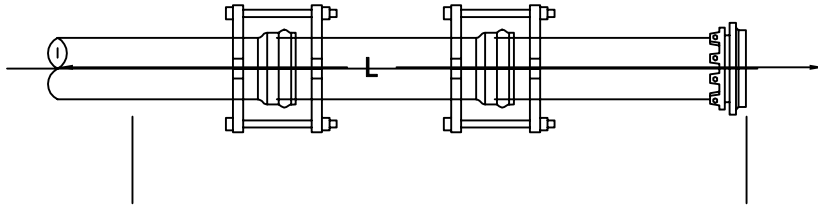

1. ALL JOINTS WITHIN LENGTH "L" MUST BE RESTRAINED. USE RETAINER GLAND AT MECHANICAL JOINTS AND HARNESS WITH PUSH-ON PIPE.
2. RESTRAINED JOINT ADAPTERS SHALL BE EBAA MEGALUG WITH MEGA-BOND COATING OR APPROVED EQUAL.
3. BELL HARNESS SHALL BE MEGALUG BELL RESTRAINT HARNESSES WITH MEGA-BOND COATING OR APPROVED EQUAL.
4. ALL NUTS, BOLTS, MECHANICAL JOINTS, AND BELL HARNESS RESTRAINTS SHALL INCLUDE 304 OR 316 STAINLESS STEEL HARDWARE, BE COATED WITH AN ANTI-SEIZE COMPOUND, AND BE WRAPPED IN VISQUEEN PLASTIC SHEETING AND SECURED IN PLACE WITH PVC TAPE.
5. ALL WATER SYSTEM MATERIALS THAT COME INTO CONTACT WITH POTABLE WATER SHALL BE ANSI/NSF STANDARD-61 CERTIFIED OR EQUIVALENT AND SHALL BE LEAD FREE.

PIPE SIZE

4	6	8	10	12	14	16
52	73	96	115	136	155	174

RESTRAINED LENGTHS, "L" (IN FEET)

GENERAL NOTES ON USE OF RESTRAINED JOINT LENGTHS:

THESE RESTRAINED LENGTH CALCULATIONS ARE BASED ON THE FOLLOWING DESIGN CRITERIA:

1. THREE (3) FEET MINIMUM DEPTH OF COVER.
2. A SAFETY FACTOR OF 1.5.
3. SOIL TYPE OF SM -- SILTY GRAVEL AND SILTY SANDS AS DEFINED BY ASTM D-2487.
4. TRENCH COMPACTION OF TYPE 5 - PIPE BEDDED IN COMPACTED GRANULAR MATERIAL TO THE CENTER LINE OF PIPE, 4 INCHES MINIMUM UNDER PIPE. COMPACTED GRANULAR MATERIAL OR SELECT MATERIAL TO TOP OF THE PIPE. (APPROXIMATELY 90 PERCENT STANDARD PROCTOR DENSITY, AASHTO T-99)
5. TEST PRESSURES OF 180 PSI FOR THE 4 THROUGH 16 INCH SIZES.

IF ACTUAL CONDITIONS DIFFER FROM THOSE LISTED ABOVE OR THE REQUIRED RESTRAINED LENGTH CANNOT BE MET, CONSULT THE DESIGN ENGINEER FOR MODIFICATIONS TO THE RESTRAINED LENGTHS OR DESIGN.



ROOT CREEK WATER DISTRICT STANDARD DETAIL

PREPARED BY: STEPHEN GRISEZ
Steph Grisez
NICK BRUNO, RCWD PRESIDENT

PVC PIPE RESTRAINTS

SCALE: NOT TO SCALE

DATE ADOPTED: 8-12-2019

W-5

SHEET 5 OF 37

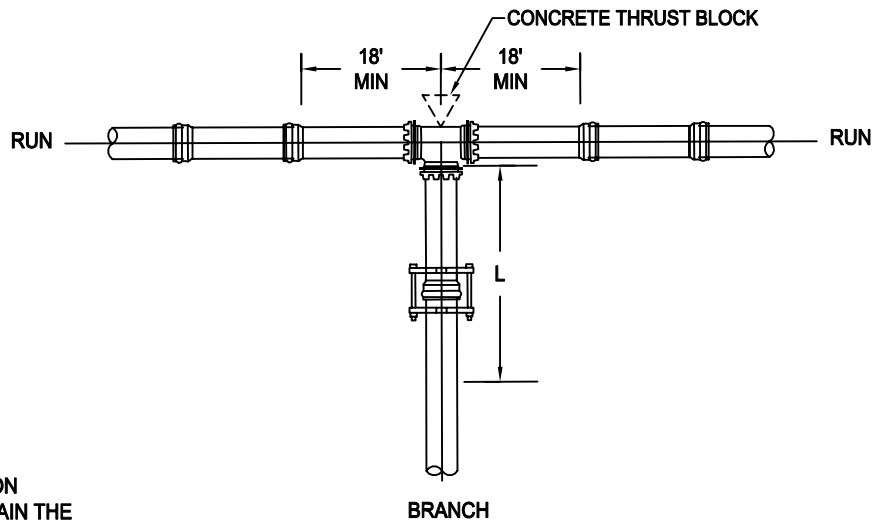

* -FOR THIS CONDITION
NEED ONLY RESTRAIN THE
BRANCH OUTLET OF THE TEE.

		RUN SIZE									
		4	6	8	10	12	14	16	18	20	24
BRANCH SIZE	4	*	*	*	*	*	*	*	*	*	*
	6		*	*	*	*	*	*	*	*	*
	8			*	*	*	*	*	*	*	*
	10				*	*	*	*	*	*	*
	12					13	*	*	*	*	*
	14						24	13	*	*	*
	16							36	25	14	*
	18								47	37	16
	20									58	39
	24										79

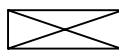

REQUIRES CALCULATION OF LENGTH OF RESTRAINT. IN THIS CONDITION REQUIRE RESTRAINT OF EACH TEE CONNECTION AND CONCRETE THRUST BLOCK.

RESTRAINED LENGTHS, "L" (IN FEET)

NOTES:

1. RESTRAIN THE TWO MECHANICAL JOINTS ON THE RUN SIDES OF THE TEE. WHEN LESS THAN A FULL 18' LENGTH OF PIPE IS INSTALLED ON EACH SIDE OF THE RUN.
2. ALL JOINTS WITHIN THE LENGTH "L" ON THE BRANCH MUST BE RESTRAINED. USE RETAINER GLAND AT MECHANICAL JOINTS AND HARNESS ON PUSH-ON PIPE.
3. RESTRAINED JOINT ADAPTERS SHALL BE EBAA MEGALUG WITH MEGA-BOND COATING OR APPROVED EQUAL.
4. BELL HARNESS SHALL BE MEGALUG BELL RESTRAINT HARNESSES WITH MEGA-BOND COATING OR APPROVED EQUAL.
5. ALL NUTS, BOLTS, MECHANICAL JOINTS, AND BELL HARNESS RESTRAINTS SHALL INCLUDE 304 OR 316 STAINLESS STEEL HARDWARE, BE COATED WITH AN ANTI-SEIZE COMPOUND, AND BE WRAPPED IN VISQUEEN PLASTIC SHEETING AND SECURED IN PLACE WITH PVC TAPE.
6. ALL WATER SYSTEM MATERIALS THAT COME INTO CONTACT WITH POTABLE WATER SHALL BE ANS/NSF STANDARD-61 CERTIFIED OR EQUIVALENT AND SHALL BE LEAD FREE.



ROOT CREEK WATER DISTRICT
STANDARD DETAIL

PREPARED BY: STEPHEN GRISEZ
Stephen Grisez
NICK BRUNO, RCWD PRESIDENT

DUCTILE IRON TEE RESTRAINTS

SCALE: NOT TO SCALE

DATE ADOPTED: 12-9-2019

W-6

SHEET 6 OF 39

HORIZONTAL BEND

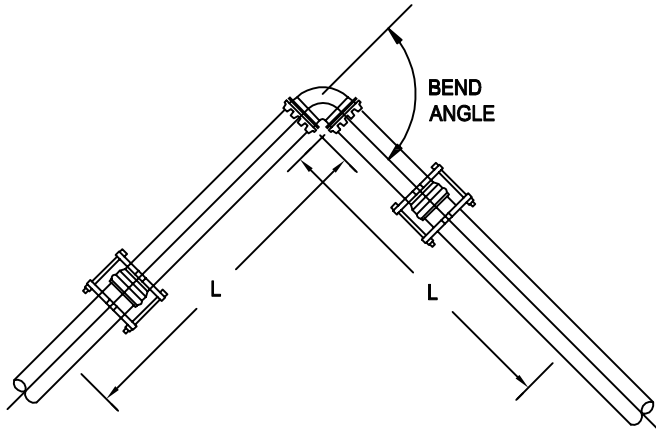

1. ALL JOINTS WITHIN LENGTH "L" MUST BE RESTRAINED. USE RETAINER GLAND AT MECHANICAL JOINTS AND HARNESS WITH PUSH-ON PIPE.
2. RESTRAINED JOINT ADAPTERS SHALL BE EBAA MEGALUG WITH MEGA-BOND COATING OR APPROVED EQUAL.
3. BELL HARNESS SHALL BE MEGALUG BELL RESTRAINT HARNESSES WITH MEGA-BOND COATING OR APPROVED EQUAL.
4. ALL NUTS,BOLTS,MECHANICAL JOINTS, AND BELL HARNESS RESTRAINTS SHALL INCLUDE 304 OR 316 STAINLESS STEEL HARDWARE, BE COATED WITH AN ANTI-SEIZE COMPOUND, AND BE WRAPPED IN VISQUEEN PLASTIC SHEETING AND SECURED IN PLACE WITH PVC TAPE.
5. ALL WATER SYSTEM MATERIALS THAT COME INTO CONTACT WITH POTABLE WATER SHALL BE ANSI/NSF STANDARD-61 CERTIFIED OR EQUIVALENT AND SHALL BE LEAD FREE.

BEND ANGLE	SIZE						
	4	6	8	10	12	14	16
11.25	3	3	3	4	4	4	5
22.5	3	4	7	7	8	9	10
45	7	9	12	15	17	19	21
90	16	23	29	35	40	45	51

RESTRAINED LENGTHS, "L" (IN FEET)

VERTICAL BEND

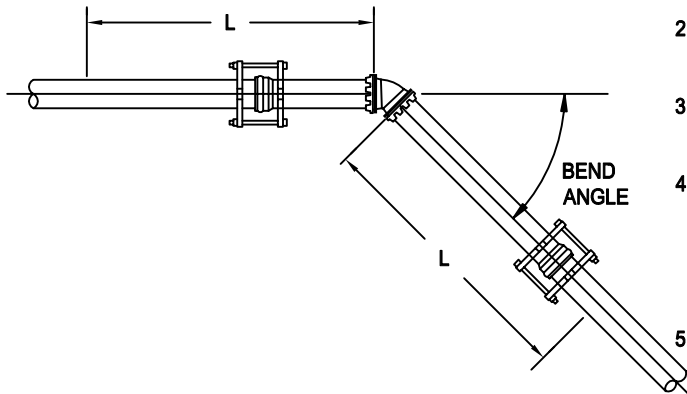

1. ALL JOINTS WITHIN LENGTH "L" MUST BE RESTRAINED. USE RETAINER GLAND AT MECHANICAL JOINTS AND HARNESS WITH PUSH-ON PIPE.
2. RESTRAINED JOINT ADAPTERS SHALL BE EBAA MEGALUG WITH MEGA-BOND COATING OR APPROVED EQUAL.
3. BELL HARNESS SHALL BE MEGALUG BELL RESTRAINT HARNESSES WITH MEGA-BOND COATING OR APPROVED EQUAL.
4. ALL NUTS,BOLTS,MECHANICAL JOINTS, AND BELL HARNESS RESTRAINTS SHALL INCLUDE 304 OR 316 STAINLESS STEEL HARDWARE, BE COATED WITH AN ANTI-SEIZE COMPOUND, AND BE WRAPPED IN VISQUEEN PLASTIC SHEETING AND SECURED IN PLACE WITH PVC TAPE.
5. ALL WATER SYSTEM MATERIALS THAT COME INTO CONTACT WITH POTABLE WATER SHALL BE ANSI/NSF STANDARD-61 CERTIFIED OR EQUIVALENT AND SHALL BE LEAD FREE.

BEND ANGLE	SIZE						
	4	6	8	10	12	14	16
11.25	3	5	7	8	8	10	11
22.5	7	11	12	15	17	20	22
45	15	19	25	31	36	41	46

RESTRAINED LENGTHS, "L" (IN FEET)



ROOT CREEK WATER DISTRICT STANDARD DETAIL

PREPARED BY: STEPHEN GRISEZ
Stephen Grisez
NICK BRUNO, RCWD PRESIDENT

DUCTILE IRON BEND RESTRAINTS

SCALE: NOT TO SCALE

DATE ADOPTED: 8-12-2019

W-7

SHEET 7 OF 37

DEAD END FOR DUCTILE IRON PIPE

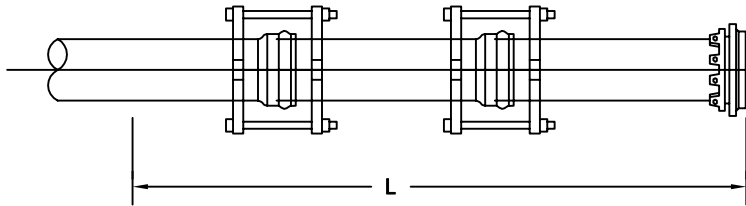

1. ALL JOINTS WITHIN LENGTH "L" MUST BE RESTRAINED. USE RETAINER GLAND AT MECHANICAL JOINTS AND HARNESS WITH PUSH-ON PIPE.
2. RESTRAINED JOINT ADAPTERS SHALL BE EBAA MEGALUG WITH MEGA-BOND COATING OR APPROVED EQUAL.
3. BELL HARNESS SHALL BE MEGALUG BELL RESTRAINT HARNESSES WITH MEGA-BOND COATING OR APPROVED EQUAL.
4. ALL NUTS,BOLTS,MECHANICAL JOINTS, AND BELL HARNESS RESTRAINTS SHALL INCLUDE 304 OR 316 STAINLESS STEEL HARDWARE, BE COATED WITH AN ANTI-SEIZE COMPOUND, AND BE WRAPPED IN VISQUEEN PLASTIC SHEETING AND SECURED IN PLACE WITH PVC TAPE.
5. ALL WATER SYSTEM MATERIALS THAT COME INTO CONTACT WITH POTABLE WATER SHALL BE ANSI/NSF STANDARD-61 CERTIFIED OR EQUIVALENT AND SHALL BE LEAD FREE.

PIPE SIZE

4	6	8	10	12	14	16
33	47	61	73	86	98	111

RESTRAINED LENGTHS, "L" (IN FEET)

GENERAL NOTES ON USE OF RESTRAINED JOINT LENGTHS:

THESE RESTRAINED LENGTH CALCULATIONS ARE BASED ON THE FOLLOWING DESIGN CRITERIA:

1. THREE (3) FEET MINIMUM DEPTH OF COVER.
2. A SAFETY FACTOR OF 1.5
3. SOIL TYPE OF SM - - SILTY GRAVEL AND SILTY SANDS AS DEFINED BY ASTM D-2487.
4. TRENCH COMPACTION OF TYPE 5 - PIPE BEDDED IN COMPACTED GRANULAR MATERIAL TO THE CENTER LINE OF PIPE, 4 INCHES MINIMUM UNDER PIPE. COMPACTED GRANULAR MATERIAL OR SELECT MATERIAL TO TOP OF THE PIPE. (APPROXIMATELY 90 PERCENT STANDARD PROCTOR DENSITY, AASHTO T-99)
5. TEST PRESSURES OF 150 PSI FOR THE 4 THROUGH 16 INCH SIZES

IF ACTUAL CONDITIONS DIFFER FROM THOSE LISTED ABOVE OR THE REQUIRED RESTRAINED LENGTH CANNOT BE MET, CONSULT THE DESIGN ENGINEER FOR MODIFICATIONS TO THE RESTRAINED LENGTHS OR DESIGN



**ROOT CREEK WATER DISTRICT
STANDARD DETAIL**

PREPARED BY: STEPHEN GRISEZ
Stephen Grisez
NICK BRUNO, RCWD PRESIDENT

DUCTILE IRON PIPE RESTRAINTS

SCALE: NOT TO SCALE

DATE ADOPTED: 8-12-2019

W-8

SHEET 8 OF 37

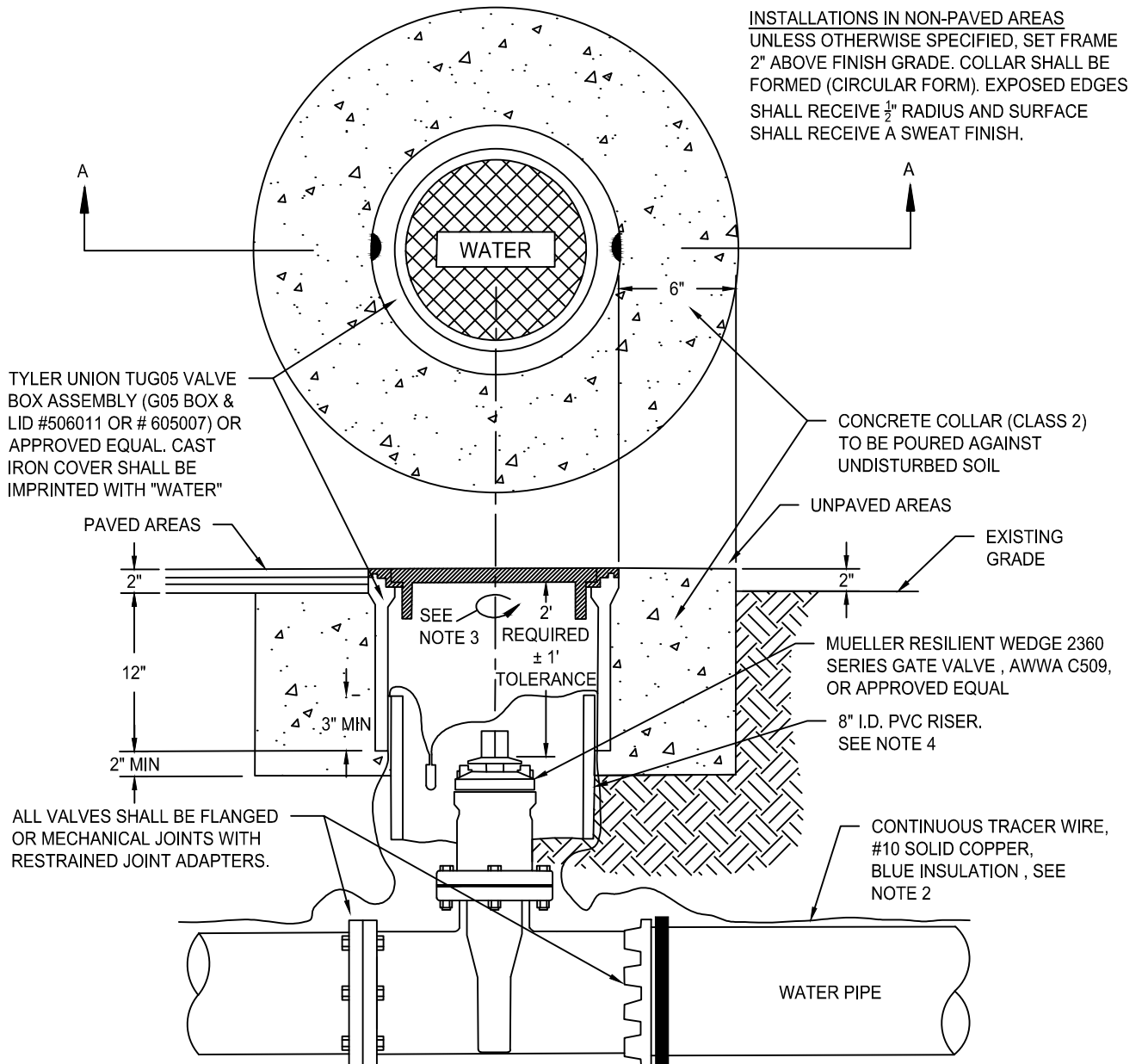

NOTES:

1. PROVIDE EXTENSIONS AS NECESSARY.
2. INSTALL TRACER WIRE LEAVING A 12" MIN. LEAD INSIDE OF G5 BOX.
3. VALVE TO TURN COUNTERCLOCKWISE TO OPEN
4. RISER LENGTH TO BE DETERMINED BY FIELD CONDITIONS.
5. VALVE NUT TO BE CENTERED IN RISER.
6. RISER TO BE PLUMB.
7. VALVES 12" AND SMALLER SHALL BE GATE VALVES.
8. VALVES GREATER THAN 12" SHALL BE BUTTERFLY VALVES.
9. VALVES SHALL BE FLANGED, RESTRAINED MECHANICAL JOINTS, OR AS APPROVED BY ENGINEER ON A CASE BY CASE BASIS.
10. RISER SHALL BE SDR-35 OR BETTER.
11. RESTRAINED JOINT ADAPTERS SHALL BE EBAA MEGALUG WITH MEGA-BOND COATING OR APPROVED EQUAL.
12. BELL HARNESS SHALL BE MEGALUG BELL RESTRAINT HARNESSES WITH MEGA-BOND COATING OR APPROVED EQUAL.
13. ALL NUTS, BOLTS, MECHANICAL JOINTS, AND BELL HARNESS RESTRAINTS SHALL INCLUDE 304 OR 316 STAINLESS STEEL HARDWARE, BE COATED WITH AN ANTI-SEIZE COMPOUND, AND BE WRAPPED IN VISQUEEN PLASTIC SHEETING AND SECURED IN PLACE WITH PVC TAPE.
14. ALL WATER SYSTEM MATERIALS THAT COME INTO CONTACT WITH POTABLE WATER SHALL BE ANS/NSF STANDARD-61 CERTIFIED OR EQUIVALENT AND SHALL BE LEAD FREE.
15. VALVES TO BE INSTALLED AT TEES, CROSSES, AND ELBOWS. MAXIMUM LENGTH BETWEEN VALVES NOT TO EXCEED 500 FEET.



**ROOT CREEK WATER DISTRICT
STANDARD DETAIL**

PREPARED BY: STEPHEN GRISEZ
Stephen Grisez
NICK BRUNO, RCWD PRESIDENT

WATER VALVE

SCALE: NOT TO SCALE

DATE ADOPTED: 4-14-2025

W-9

SHEET 9 OF 39

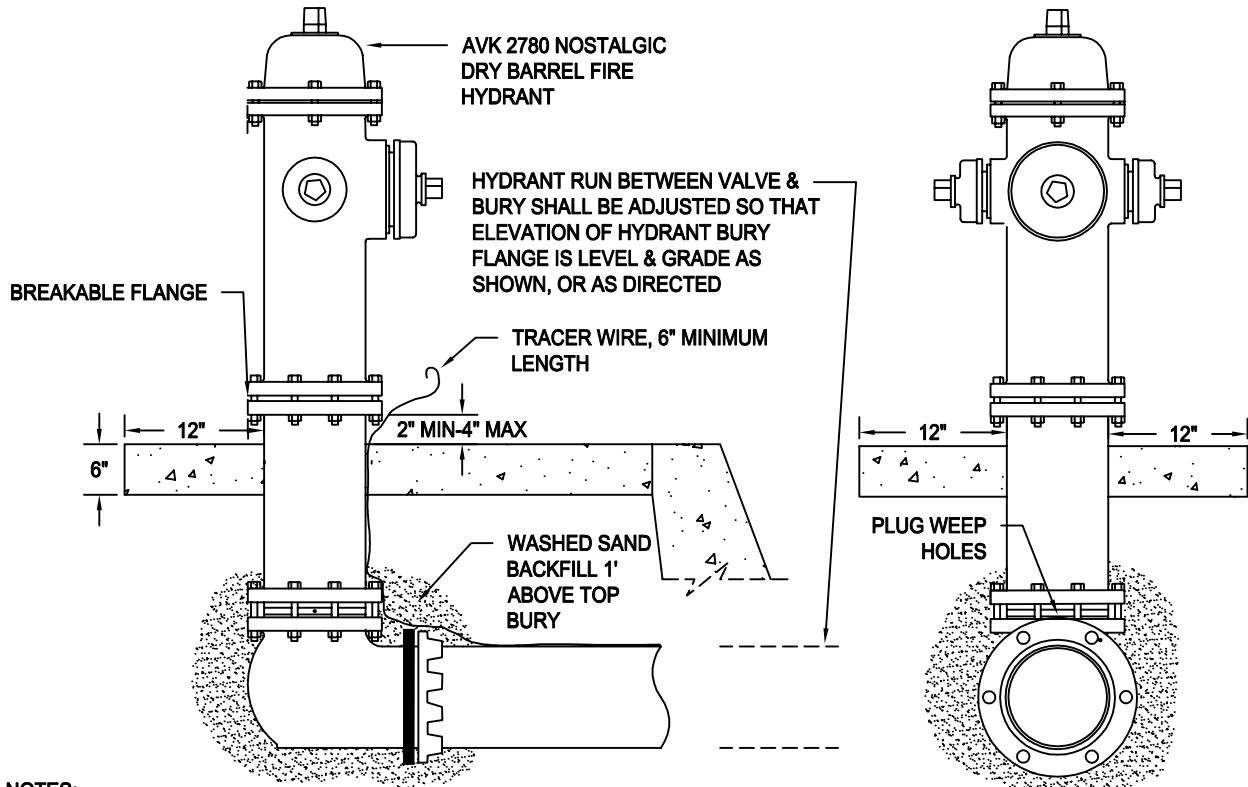

NOTES:

1. FIRE HYDRANT GATE VALVE SHALL BE FLANGE X MECHANICAL JOINT WITH RESTRAINED JOINT ADAPTER AS NOTED BELOW.
2. FIRE HYDRANT BURY SHALL BE MECHANICAL JOINT WITH RESTRAINED JOINT ADAPTER AS NOTED BELOW.
3. THE PIPE EXTENDING FROM THE FIRE HYDRANT GATE VALVE TO THE FIRE HYDRANT BURY SHALL BE RESTRAINED AS NOTED BELOW.
4. RESTRAINED JOINT ADAPTERS SHALL BE EBAA MEGALUG WITH MEGA-BOND COATING OR APPROVED EQUAL.
5. BELL HARNESS SHALL BE MEGALUG BELL RESTRAINT HARNESSSES WITH MEGA-BOND COATING OR APPROVED EQUAL.
6. ALL NUTS, BOLTS, MECHANICAL JOINTS, AND BELL HARNESS RESTRAINTS SHALL INCLUDE 304 OR 316 STAINLESS STEEL HARDWARE, BE COATED WITH AN ANTI-SEIZE COMPOUND, AND BE WRAPPED IN VISQUEEN PLASTIC SHEETING AND SECURED IN PLACE WITH PVC TAPE.
7. ALL FIRE HYDRANTS SHALL BE SET IN A CONCRETE SLAB MEASURING AT LEAST 12" ON ALL SIDES, 6" THICK. IF COMBINED WITH OTHER SERVICES OR APPURTENANCES IN A SINGLE PAD, THE PAD SHALL INCLUDE DEEP SCORE JOINTS BETWEEN EACH ASSEMBLY. EXPOSED EDGES SHALL RECEIVE $\frac{1}{2}$ " RADIUS AND SURFACE SHALL RECEIVE A SWEAT FINISH.
8. EDGE OF PAVEMENT TO CENTER OF FIRE HYDRANT SHALL BE 48" OR AS DIRECTED BY OWNER/RCWD (PROVIDES 24" FROM EP TO BOLLARDS). FG SHALL BE 2" ABOVE EP GRADE.
9. C & G OR AC DIKE AREA WITH NO SIDEWALKS - FACE OF CURB TO CENTER OF FIRE HYDRANT SHALL BE 30" OR AS DIRECTED BY OWNER/RCWD.
10. C & G AND SEPARATED SIDEWALK - FACE OF CURB TO CENTER OF FIRE HYDRANT SHALL BE 30".
11. C & G AND MONOLITHIC SIDEWALK - BACK OF SIDEWALK TO CENTER OF FIRE HYDRANT SHALL BE 18".
12. COMPONENTS: NOZZLE SECTION, BARRELS, STANDPIPE FLANGES, BREAKABLE FLANGE, MAINVALVE FLANGE, BASE, CAPS, WEATHERSHED, NOZZLES, VALVE SEAT RING, DRAIN RING, OPERATING NUT, THRUST NUT, BRASS FITTINGS, BRASS PLUGS, MAIN VALVE, STEM ROD COUPLINGS, LOCK RINGS, NOZZLE, VALVE RETAINING PIN, SPRING PINS, STOP NUT, CHAIN SET, HARDWARE, BARREL GASKET, CAP GASKET, O-RINGS, LUBRICATION HOLE SEAL, ANTI-FRICTION WASHER, RESTRAINED JOINT ADAPTER.
13. OUTLETS: 2 EACH 2.5" OUTLETS
1 EACH 4.5" OUTLETS
14. COLOR: SHERWIN WILLIAMS GEORGIAN BAY SW 6509 HIGH GLOSS
15. BASE ELBOW/INLET CONFIGURATION: 6" MJ
16. HARDWARE: 304 STAINLESS, UPPER STEM ROD: 304 STAINLESS, LOWER STEM ROD: 304 STAINLESS.
17. OPENING DIRECTION: OPEN LEFT
18. DRAIN HOLE SHALL BE PLUGGED
19. ALL FIRE HYDRANTS SHALL INCLUDE A 6" GATE VALVE AT MAIN LINE TEE.
20. FIRE DEPARTMENT STREET MARKERS AND RED CURB SHALL BE PER COUNTY AND FIRE DEPT. STANDARDS.
21. ALL WATER SYSTEM MATERIALS THAT COME INTO CONTACT WITH POTABLE WATER SHALL BE ANSI/NSF STANDARD-61 CERTIFIED OR EQUIVALENT AND SHALL BE LEAD FREE.



**ROOT CREEK WATER DISTRICT
STANDARD DETAIL**

PREPARED BY: *Stephen Grisez*
STEPHEN GRISEZ
NICK BRUNO, RCWD PRESIDENT

FIRE HYDRANT INSTALLATION

SCALE: NOT TO SCALE

DATE ADOPTED: 8-12-2019

W-10

SHEET 10 OF 37

SAMPLE STATION TAG REQUIREMENTS:

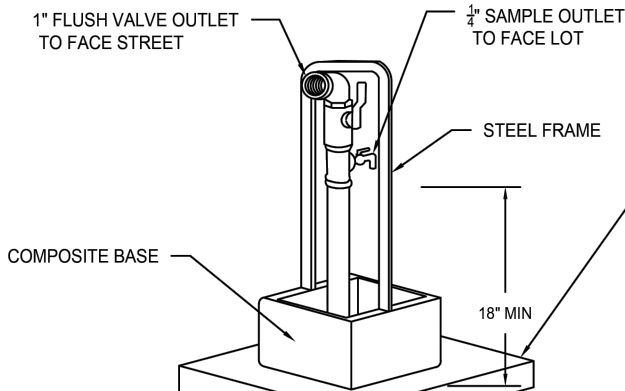
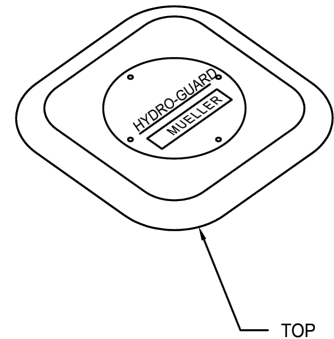
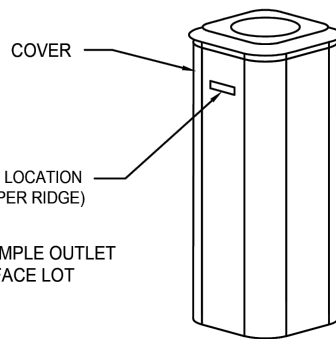
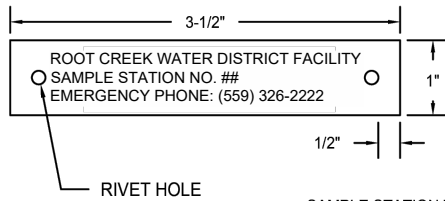

SAMPLING STATION SHALL BE SET MOUNTED TO A CONCRETE SLAB MEASURING 12" ON ALL SIDES, 6" THICK. IF COMBINED WITH OTHER SERVICES OR APPURTENANCES IN A SINGLE PAD THE PAD WILL INCLUDE DEEP SCORE JOINTS BETWEEN EACH ASSEMBLY. EXPOSED EDGES SHALL RECEIVE 1/2" RADIUS AND SURFACE SHALL RECEIVE A SWEAT FINISH.

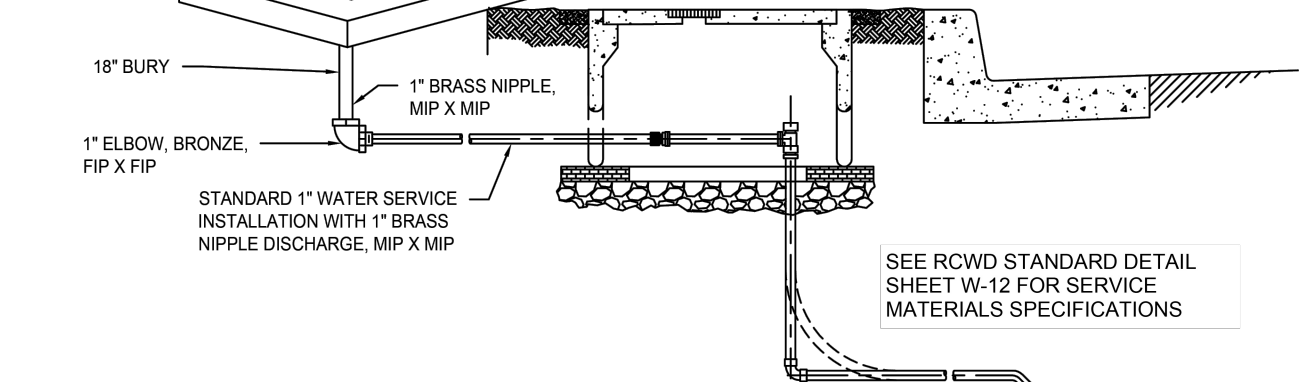

NOTES:

1. SAMPLING STATIONS SHALL BE MUELLER SAFETY GUARD BSS01 WITH 18" BURY, ALL BRASS PIPING, NO LEAD BRASS, REMOVABLE POWDER COATED STEEL ENCLOSURE, AND SECURITY KIT OR APPROVED EQUAL.
2. SAMPLING STATIONS SHALL BE 18" BURY, WITH A 1" FIP INLET AND A 1" FIP DISCHARGE. A 1/4" BENT-NOSE SAMPLING BIBB SHALL BE LOCATED BEFORE DISCHARGE. OUTLET PORTS SHALL BE POSITIONED WITH 180 DEGREES OF SEPARATION.
3. ALL STATIONS SHALL BE ENCLOSED IN A LOCKABLE, COMPOSITE HOUSING WITH INTEGRAL LOCK & FURNISH 2 KEYS PER UNIT.
4. WHEN OPENED, THE STATION SHALL REQUIRE NO KEY FOR OPERATION AND THE WATER SHALL FLOW IN ALL BRASS WATERWAY.
5. ALL WORKING PARTS SHALL BE OF BRASS AND SERVICEABLE FROM ABOVE GROUND WITH NO DIGGING.
6. A 1" BALL VALVE SHALL CONTROL THE WATER FLOW, AND SHALL BE LOCATED BEFORE THE SAMPLING BIBB.
7. SAMPLING STATION SHALL BE STANDARD FACTORY BLUE COLOR.
8. 1" WATER SERVICE ASSEMBLY SHALL BE INSTALLED PER DETAIL W-12.
9. ALL WATER SYSTEM MATERIALS THAT COME INTO CONTACT WITH POTABLE WATER SHALL BE ANSI/NSF STANDARD-61 CERTIFIED OR EQUIVALENT AND SHALL BE LEAD FREE.
10. ENCLOSURES SHALL INCLUDE BRONZE COLORED METAL ENGRAVED SAMPLE STATION TAGS FABRICATED BY SUNNYSIDE TROPHY 559-252-9273 OR APPROVED EQUAL. SAMPLE STATION TAGS SHALL BE ATTACHED TO PLASTIC COVER BY MEANS OF AN ADHESIVE BACKING AND 2 EACH RIVETED CONNECTION POINTS. SAMPLE STATION TAG TO BE LOCATED AS NOTED ABOVE FACING STREET.
11. FURNISH 1 EACH ASSEMBLED 1" X 20" BRASS NIPPLE, MIP X MIP AND 1" UNION, FIP X FIP. ASSEMBLED UNIT SHALL BE STORED LOOSE INSIDE ENCLOSURE AND WILL BE USED BY OPERATORS TO TEMPORARILY EXTEND THE FLUSH OUTLET DURING FLUSHING AND SAMPLING ACTIVITIES.

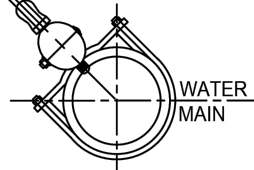

WATER METER & TRANSMITTER ASSEMBLY:

1. MANUFACTURER: BADGER
2. MODEL NUMBER: ORION 3G
3. UNITS: CUBIC FEET
4. INSTALLATION: METER & TRANSMITTER SHALL BE INSTALLED BY ROOT CREEK WATER DISTRICT
5. METER: BADGER E-SERIES (STAINLESS)

WATER SERVICE TRENCH NOTE:

NO LIME OR CEMENT-TREATED SOILS ALLOWED WITHIN 12" OF THE WATER SERVICE LINE. FOR INSTALLATIONS WHERE LIME OR CEMENT-TREATED SOILS ARE PRESENT, BACKFILL THE SERVICE LINE WITH CLEAN SOILS MEETING THE STANDARD FOR IMPORTED BACKFILL MATERIAL PER DISTRICT STANDARD SPECIFICATIONS SECTION 17.3.2.

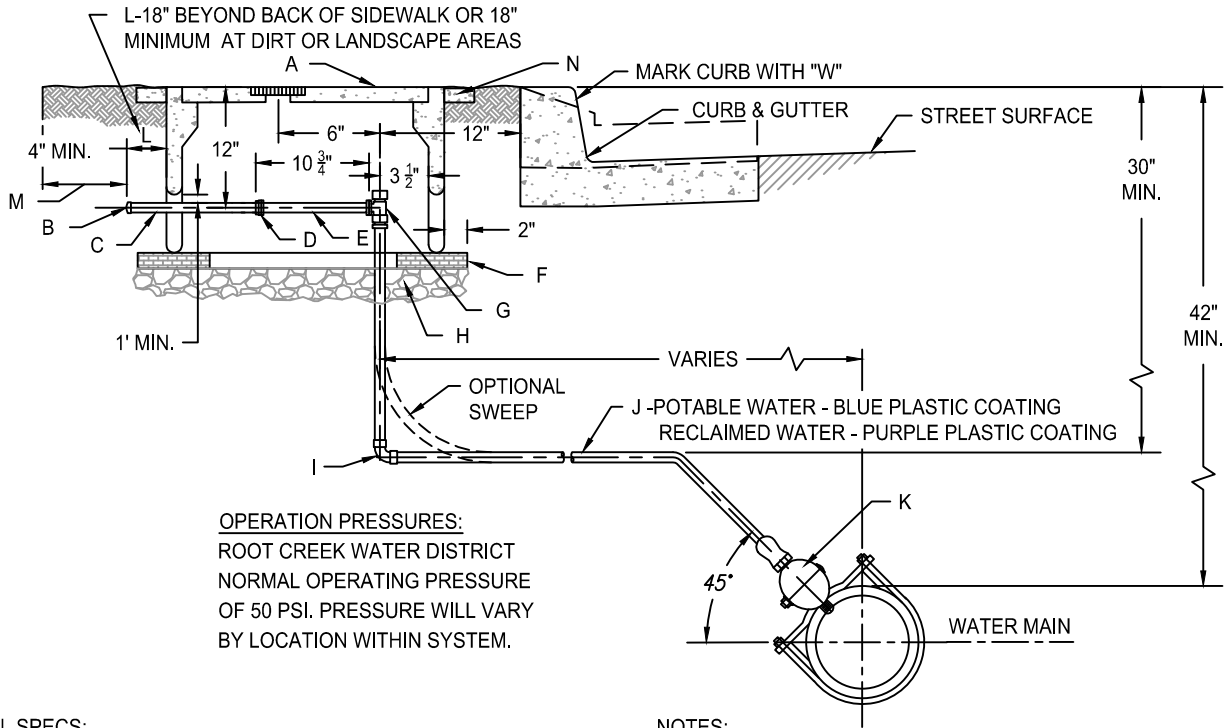

OPERATION PRESSURES:
 ROOT CREEK WATER DISTRICT
 NORMAL OPERATING PRESSURE
 OF 50 PSI. PRESSURE WILL VARY
 BY LOCATION WITHIN SYSTEM.

MATERIAL SPECS:

- A. OLD CASTLE BOX, FL12T OR (NO MOUSEHOLES); LID, FL12 WITH BADGER ORION PROBE HOLE; LID SHALL BE LABELED "RCWD"
- B. TEMP 1" CAP, FIP, BRASS FITTING
- C. 1" NIPPLE, LENGTH AS REQUIRED, MIP X MIP, BRASS, TAPE WRAPPED, NO JOINTS
- D. 1" METER TAILPIECE A.Y. McDONALD "NO LEAD" 74624-22 OR APPROVED EQUAL
- E. 1 1/4" X 10 3/4" PVC METER SPOOL (SCH 80)
- F. COMMON CONCRETE CONCRETE BRICKS SHALL BE PLACED AT CORNERS TO SUPPORT METER BOX, 4 PER BOX
- G. 1" ANGLE METER STOP, A.Y. McDONALD "NO LEAD" 74602B-22 300 PSI OR FORD BFA43-xxxW-CF-NL OR APPROVED EQUAL
- H. 4" THICK 3/4" CRUSHED ROCK PLACED OVER COMPACTED NATIVE SUBGRADE (90% MINIMUM RELATIVE COMPACTION)
- I. COMP X COMP 90° ELL, A.Y. McDONALD OR APPROVED EQUAL "NO LEAD" 74701-22
- J. 1" TYPE "K" SOFT DRAWN COPPER TUBING WITH PLASTIC COATING, STREAMLINE OR APPROVED EQUAL, ALL EXPOSED COPPER SHALL BE TAPE WRAPPED
- K. 1" CORPORATION STOP, A.Y. McDONALD "NO LEAD" 74701-22 OR FORD (FB1000-4-NL) 300 PSI WORKING PRESSURE OR APPROVED EQUAL
- L. ROOT CREEK WATER DISTRICT RESPONSIBILITY
- M. CUSTOMERS RESPONSIBILITY
- N. ALL METER BOXES SHALL BE LOCATED BEHIND CURB & GUTTER AND SHALL BE INCORPORATED INTO SIDEWALK. METER BOXES LOCATED IN DIRT OR LANDSCAPE AREAS SHALL BE SET IN A CONCRETE SLAB MEASURING AT LEAST 12" ON ALL SIDES AND 6" THICK. IF COMBINED WITH OTHER SERVICES OR APPURTENANCES IN A SINGLE PAD THE PAD SHALL INCLUDE DEEP SCORE JOINTS BETWEEN EACH ASSEMBLY. EXPOSED EDGES SHALL RECEIVED 1/2" RADIUS AND SURFACE SHALL RECEIVE A SWEAT FINISH.

NOTES:

1. EDGE OF PAVEMENT TO CENTER OF ANGLE METER STOP SHALL BE 48" OR AS DIRECTED BY OWNER/RCWD (PROVIDES 24" FRO EP TO BOLLARDS. FG SHALL BE 2" ABOVE EP GRADE.)
2. C&G OR AC DIKE AREA WITH NO SIDEWALKS BACK OF CURB TO CENTER OF ANGLE METER STOP SHALL BE 12" OR AS DIRECTED BY OWNER/RCWD.
3. C&G AND SEPARATED SIDEWALK BACK OF CURB TO CENTER OF ANGLE METER STOP SHALL BE 12".
4. C&G AND MONLITHIC SIDEWALK BACK OF CURB TO CENTER OF ANGLE METER STOP SHALL BE 12" (METER BOX IN SIDEWALK).
5. RCWD MINIMUM WATER SERVICE SIZE IS 1.50" AND 1.00" SERVICE SIZE REQUIRES A WRITTEN SUBMITTAL TO THE DISTRICT ENGINEER FOR APPROVAL.
6. WATER SERVICES SHALL NOT BE ALLOWED IN DRIVEWAY APPROACH AREAS AT ANY RESIDENTIAL OR COMMERCIAL LOCATION.
7. ALL COPPER FITTINGS SHALL BE CAMPAK COMPRESSION-TYPE.
8. FOR PVC WATER MAIN TAPS, SERVICE SADDLES WITH CIRCUMFERENTIAL TYPE BANDS SHAPED TO FIT THE ACTUAL O.D. OF THE PIPE, AND HAVING A MINIMUM BEARING WIDTH OF 3" (1.5" PER BAND) SHALL BE USED. FOR DUCTILE AND CAST IRON MAINS, USE BRONZE OR DUCTILE IRON SERVICE SADDLES, WITH BRONZE OR STAINLESS DOUBLE STRAPS.
9. SADDLES-PVC C900 MCDONALD 3855 & PVC C905 MCDONALD 3845B OR FORD 202BSD-xxx-TAP OR APPROVED EQUAL.
10. ALL WATER SYSTEM MATERIALS THAT COME INTO CONTACT WITH POTABLE WATER SHALL BE ANSI/NSF STANDARD-61 CERTIFIED OR EQUIVALENT AND SHALL BE LEAD FREE.

 <p>RCWD MANAGING RESOURCES FOR A BETTER FUTURE</p>	<p>ROOT CREEK WATER DISTRICT STANDARD DETAIL</p>	<p>1 IN SERVICE CONNECTION & METER BOX INSTALLATION</p>	
	<p>PREPARED BY: STEPHEN GRISEZ</p> <p>NICK BRUNO, RCWD PRESIDENT</p>	<p>SCALE: NOT TO SCALE</p> <p>DATE ADOPTED: 12-8-2025</p>	<p>W-12</p> <p>SHEET 12 OF 39</p>

WATER METER & TRANSMITTER ASSEMBLY:

1. MANUFACTURER: BADGER
2. MODEL NUMBER: ORION 3G
3. UNITS: CUBIC FEET
4. INSTALLATION: METER & TRANSMITTER SHALL BE INSTALLED BY ROOT CREEK WATER DISTRICT
5. METER: BADGER E SERIES (STAINLESS)

WATER SERVICE TRENCH NOTE:

NO LIME OR CEMENT-TREATED SOILS ALLOWED WITHIN 12" OF THE WATER SERVICE LINE. FOR INSTALLATIONS WHERE LIME OR CEMENT-TREATED SOILS ARE PRESENT, BACKFILL THE SERVICE LINE WITH CLEAN SOILS MEETING THE STANDARD FOR IMPORTED BACKFILL MATERIAL PER DISTRICT STANDARD SPECIFICATIONS SECTION 17.3.2.

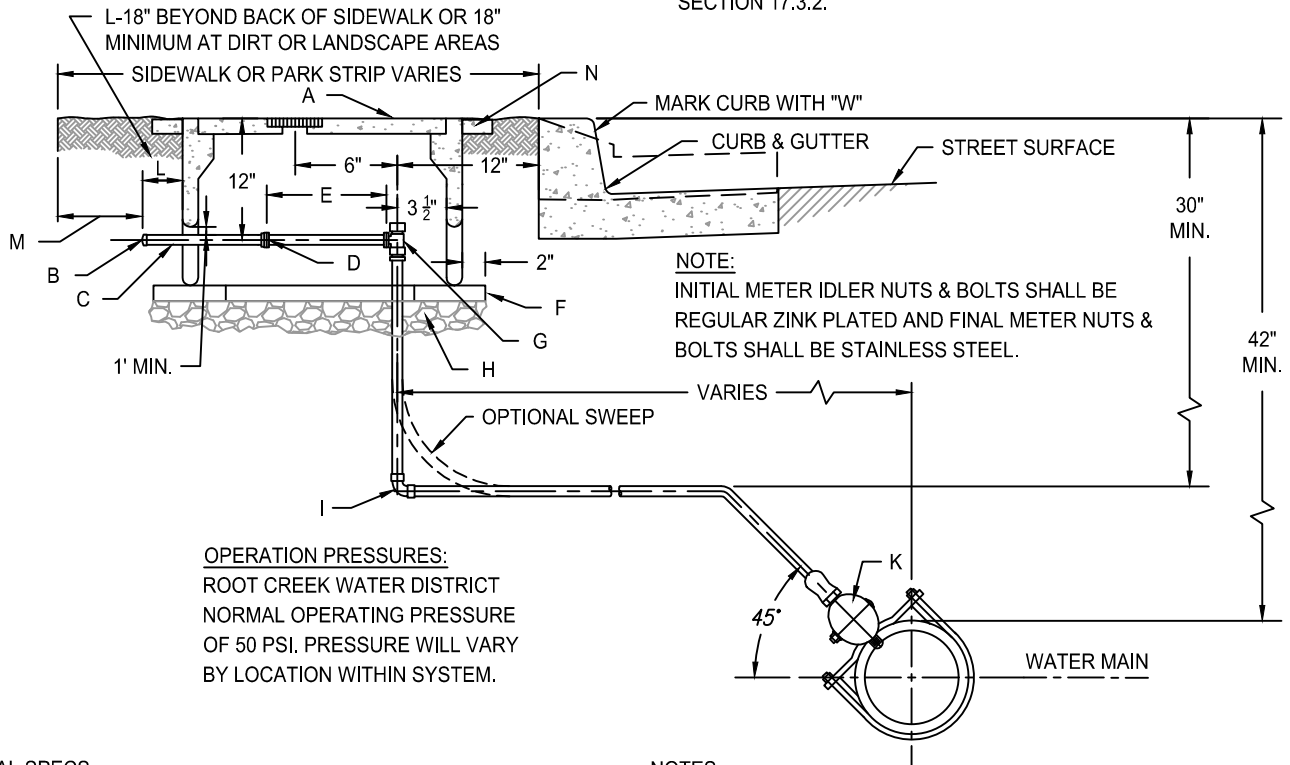

OPERATION PRESSURES:
 ROOT CREEK WATER DISTRICT
 NORMAL OPERATING PRESSURE
 OF 50 PSI. PRESSURE WILL VARY
 BY LOCATION WITHIN SYSTEM.

MATERIAL SPECS:

- A. OLD CASTLE BOX, FL30T (NO MOUSEHOLES);LID, FL30 WITH BADGER ORION PROBE HOLE; LID SHALL BE LABELED "RCWD"
- B. TEMP 1.5" CAP,FIP,BRASS FITTING
- C. 1.5" NIPPLE, LENGTH AS REQUIRED, MIP X MIP, BRASS , TAPE WRAPPED, NO JOINTS.
- D. 1.5" BRONZE FLANGE
- E. FLANGED METER SPOOL (SCH 80) 13" SPOOL FOR 1.5" METER
- F. COMMON CONCRETE BRICKS SHALL BE PLACED AT CORNERS TO SUPPORT METER BOX, 4 PER BOX.
- G. 1.5" ANGLE METER STOP, A.Y Mc DONALD "NO LEAD" 74602B-22 300 PSI OR FORD BFA43-xxxW-CF-NL OR APPROVED EQUAL.
- H. 4" THICK 3/4" CRUSHED ROCK PLACED OVER COMPACTED NATIVE SUBGRADE (90% MINIMUM RELATIVE COMPACTION)
- I. COMP X COMP 90° ELL, A.Y. McDONALD OR APPROVED EQUAL "NO LEAD" 74761-22
- J. 1.5" TYPE "K" SOFT DRAWN COPPER TUBING WITH PLASTIC COATING, STREAMLINE OR APPROVED EQUAL, RUNS LONGER THAN 20' SHALL BE UNCOATED AND INSTALLED IN HDPE POLYBAG, ALL EXPOSED COPPER SHALL BE TAPE WRAPPED
- K. 1.5" CORPORATION STOP, A.Y. Mc DONALD "NO LEAD" 74701-22 OR FORD (FB1000-4-NL) 300 PSI WORKING PRESSURE OR APPROVED EQUAL
- L. ROOT CREEK WATER DISTRICT RESPONSIBILITY
- M. CUSTOMER RESPONSIBILITY
- N. ALL METER BOXES SHALL BE LOCATED BEHIND CURB & GUTTER AND SHALL BE INCORPORATED INTO SIDEWALK. METER BOXES LOCATED IN DIRT OR LANDSCAPE AREAS SHALL BE SET IN A CONCRETE SLAB MEASURING AT LEAST 12" ON ALL SIDES AND 6" THICK. IF COMBINED WITH OTHER SERVICES OR APPURTENANCES IN A SINGLE PAD THE PAD WILL INCLUDE DEEP SCORE JOINTS BETWEEN EACH ASSEMBLY. EXPOSED EDGES SHALL RECEIVE 1/2" RADIUS AND SURFACE SHALL RECEIVE A SWEAT FINISH.

NOTES:

1. EDGE OF PAVEMENT TO CENTER OF ANGLE METER STOP SHALL BE 48" OR AS DIRECTED BY OWNER/RCWD (PROVIDES 24" FRO EP TO BOLLARDS). FG SHALL BE 2" ABOVE EP GRADE.
2. C&G OR AC DIKE AREA WITH NO SIDEWALKS BACK OF CURB TO CENTER OF ANGLE METER STOP SHALL BE 12" OR AS DIRECTED BY OWNER/RCWD.
3. C&G AND SEPARATED SIDEWALK BACK OF CURB TO CENTER OF ANGLE METER STOP SHALL BE 12".
4. C&G AND MONLITHIC SIDEWALK BACK OF CURB TO CENTER OF ANGLE METER STOP SHALL BE 12" (METER BOX IN SIDEWALK)
5. RCWD MINIMUM WATER SERVICE SIZE IS 1.50" AND 1.00" SERVICE SIZE REQUIRES A WRITTEN SUBMITTAL TO THE DISTRICT ENGINEER FOR APPROVAL.
6. WATER SERVICES SHALL NOT BE ALLOWED IN DRIVEWAY APPROACH AREAS AT ANY RESIDENTIAL OR COMMERCIAL LOCATION.
7. ALL COPPER FITTINGS SHALL BE CAMPAK COMPRESSION-TYPE.
8. FOR PVC WATER MAIN TAPS, SERVICE SADDLES WITH CIRCUMFERENTIAL TYPE BANDS SHAPED TO FIT THE ACTUAL O.D. OF THE PIPE, AND HAVING A MINIMUM BEARING WIDTH OF 3" (1.5" PER BAND) SHALL BE USED. FOR DUCTILE AND CAST IRON MAINS, USE BRONZE OR DUCTILE IRON SERVICE SADDLES, WITH BRONZE OR STAINLESS DOUBLE STRAPS.
9. SADDLES-PVC C900 MCDONALD 3855 & PVC C905 MCDONALD 3845B OR FORD 202BSD-xxx-TAP OR APPROVED EQUAL.
10. ALL WATER SYSTEM MATERIALS THAT COME INTO CONTACT WITH POTABLE WATER SHALL BE ANSI/NSF STANDARD-61 CERTIFIED OR EQUIVALENT AND SHALL BE LEAD FREE.

	ROOT CREEK WATER DISTRICT STANDARD DETAIL	1.5 IN SERVICE CONNECTION & METER BOX INSTALLATION	
	PREPARED BY: STEPHEN GRISEZ 	SCALE: NOT TO SCALE	W-13
	NICK BRUNO, RCWD PRESIDENT	DATE ADOPTED: 12-8-2025	SHEET 13 OF 39

WATER METER & TRANSMITTER ASSEMBLY:

1. MANUFACTURER: BADGER
2. MODEL NUMBER: ORION 3G
3. UNITS: CUBIC FEET
4. INSTALLATION: METER & TRANSMITTER SHALL BE INSTALLED BY ROOT CREEK WATER DISTRICT
5. METER: BADGER E-SERIES (STAINLESS)

WATER SERVICE TRENCH NOTE:

NO LIME OR CEMENT-TREATED SOILS ALLOWED WITHIN 12" OF THE WATER SERVICE LINE. FOR INSTALLATIONS WHERE LIME OR CEMENT-TREATED SOILS ARE PRESENT, BACKFILL THE SERVICE LINE WITH CLEAN SOILS MEETING THE STANDARD FOR IMPORTED BACKFILL MATERIAL PER DISTRICT STANDARD SPECIFICATIONS SECTION 17.3.2.

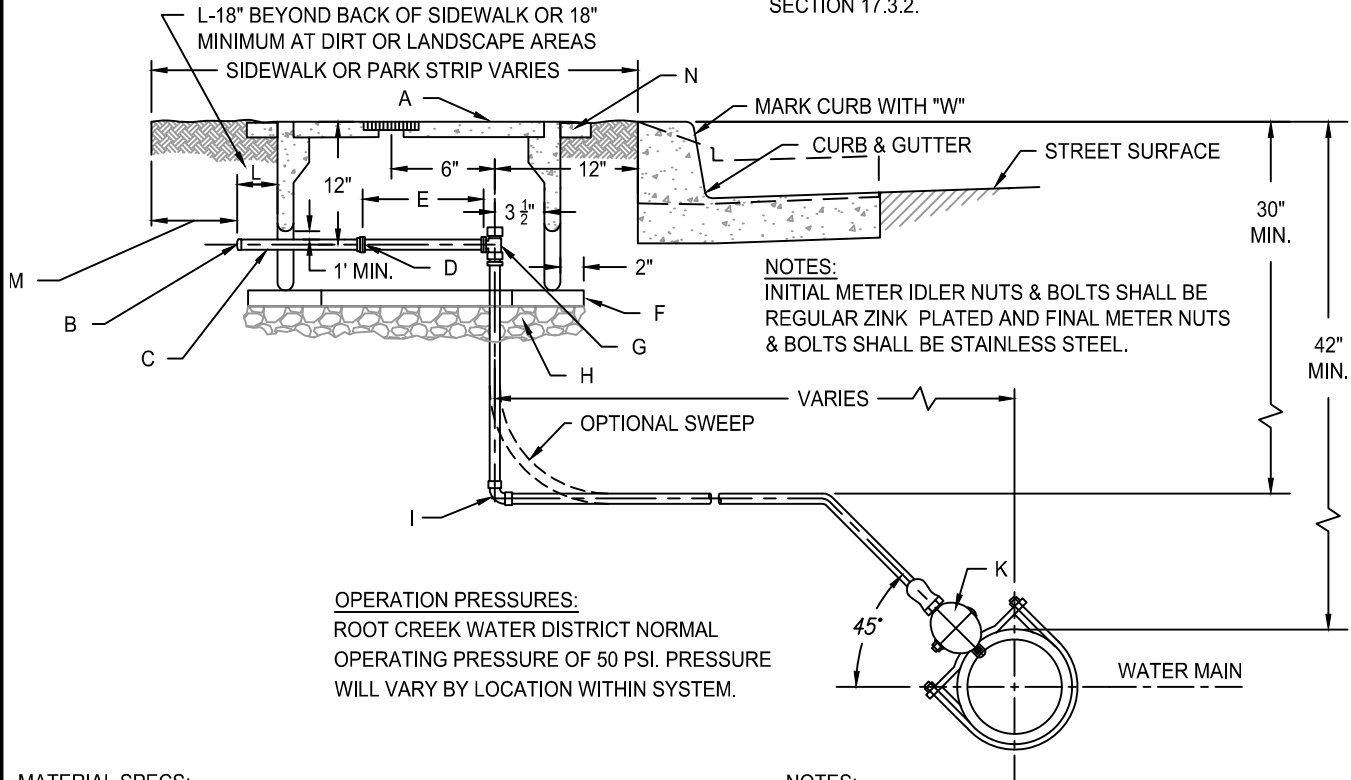

MATERIAL SPECS:

- A. OLD CASTLE BOX, FL36T (NO MOUSEHOLES); LID, FL36P WITH BADGER ORION PROBE HOLE; LID SHALL BE LABELED "RCWD"
- B. TEMP 2" CAP, FIP, BRASS FITTING
- C. 2" NIPPLE, LENGTH AS REQUIRED, MIP X MIP, BRASS, TAPE WRAPPED, NO JOINTS.
- D. 2" BRONZE FLANGE
- E. FLANGED METER SPOOL (SCH 80) 17" SPOOL FOR 2" METER
- F. COMMON CONCRETE BRICKS SHALL BE PLACED AT CORNERS TO SUPPORT METER BOX, 4 PER BOX.
- G. 2" ANGLE METER STOP, A.Y Mc DONALD "NO LEAD" 74602B-22 300 PSI OR FORD BFA43-xxxW-CF-NL OR APPROVED EQUAL.
- H. 4" THICK 3/4" CRUSHED ROCK PLACED OVER COMPACTED NATIVE SUBGRADE (90% MINIMUM RELATIVE COMPACTION)
- I. COMP X COMP 90° ELL, A.Y. McDONALD OR APPROVED EQUAL "NO LEAD" 74761-22
- J. 2" TYPE "K" SOFT DRAWN COPPER TUBING WITH PLASTIC COATING, STREAMLINE OR APPROVED EQUAL, RUNS LONGER THAN 20' SHALL BE UNCOATED AND INSTALLED IN HDPE POLYBAG, ALL EXPOSED COPPER SHALL BE TAPE WRAPPED
- K. 2" CORPORATION STOP, A.Y. Mc DONALD "NO LEAD" 74701-22 OR FORD (FB1000-4-NL) 300 PSI WORKING PRESSURE OR APPROVED EQUAL
- L. ROOT CREEK WATER DISTRICT RESPONSIBILITY
- M. CUSTOMER RESPONSIBILITY
- N. ALL METER BOXES SHALL BE LOCATED BEHIND CURB & GUTTER AND SHALL BE INCORPORATED INTO SIDEWALK. METER BOXES LOCATED IN DIRT OR LANDSCAPE AREAS SHALL BE SET IN A CONCRETE SLAB MEASURING AT LEAST 12" ON ALL SIDES AND 6" THICK. IF COMBINED WITH OTHER SERVICES OR APPURTENANCES IN A SINGLE PAD THE PAD WILL INCLUDE DEEP SCORE JOINTS BETWEEN EACH ASSEMBLY. EXPOSED EDGES SHALL RECEIVE 1/2" RADIUS AND SURFACE SHALL RECEIVE A SWEAT FINISH.

NOTES:

1. EDGE OF PAVEMENT TO CENTER OF ANGLE METER STOP SHALL BE 48" OR AS DIRECTED BY OWNER/RCWD (PROVIDES 24" FRO EP TO BOLLARDS). FG SHALL BE 2" ABOVE EP GRADE.
2. C&G OR AC DIKE AREA WITH NO SIDEWALKS-FACE OF CURB TO CENTER OF ANGLE METER STOP SHALL BE 12" OR AS DIRECTED BY OWNER/RCWD.
3. C&G AND SEPARATED SIDEALK-FACE OF CURB TO CENTER OF ANGLE METER STOP SHALL BE 12".
4. C&G AND MONLITHIC SIDEWALK-FACE OF CURB TO CENTER OF ANGLE METER STOP SHALL BE 12" (METER BOX IN SIDEWALK).
5. WATER SERVICES SHALL NOT BE ALLOWED IN DRIVEWAY APPROACH AREAS AT ANY RESIDENTIAL OR COMMERCIAL LOCATION.
6. ALL COPPER FITTINGS SHALL BE CAMPAK COMPRESSION-TYPE.
7. FOR PVC WATER MAIN TAPS, SERVICE SADDLES WITH CIRCUMFERENTIAL TYPE BANDS SHAPED TO FIT THE ACTUAL O.D. OF THE PIPE, AND HAVING A MINIMUM BEARING WIDTH OF 3" (1.5" PER BAND) SHALL BE USED. FOR DUCTILE AND CAST IRON MAINS, USE BRONZE OR DUCTILE IRON SERVICE SADDLES, WITH BRONZE OR STAINLESS DOUBLE STRAPS.
8. SADDLES-PVC C900 MCDONALD 3855 & PVC C905 MCDONALD 3845B OR FORD 202BSD-xxx-TAP OR APPROVED EQUAL.
9. ALL WATER SYSTEM MATERIALS THAT COME INTO CONTACT WITH POTABLE WATER SHALL BE ANSI/NSF STANDARD-61 CERTIFIED OR EQUIVALENT AND SHALL BE LEAD FREE.

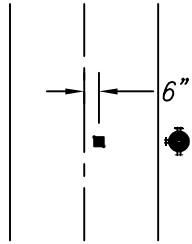

TWO LANE STREET

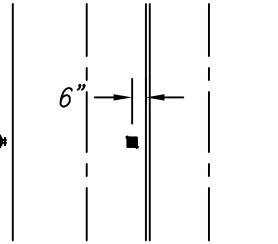

MULTI-LANE STREET

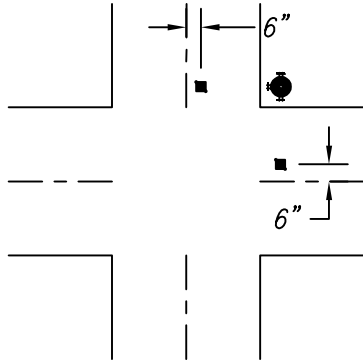

INTERSECTION

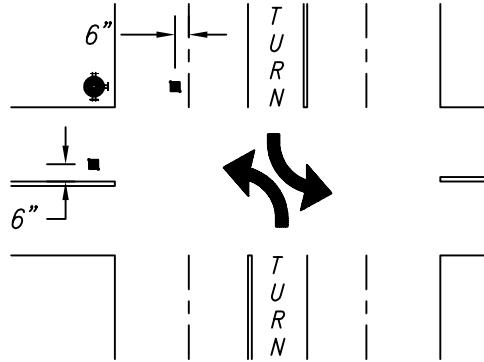

FOUR-LANES W/TURN LANE

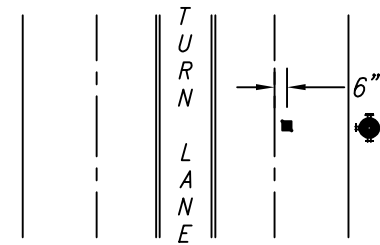

FOUR-LANES W/TURN LANE

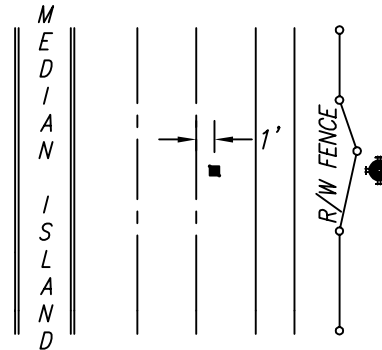

FREEWAYS AND EXPRESSWAYS

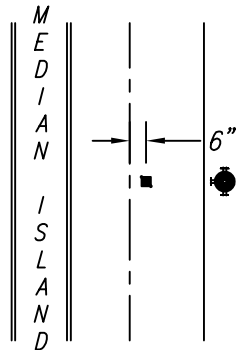

DIVIDED HIGHWAY

-  FIRE HYDRANT
-  PAVEMENT MARKER EQUAL TO STIMSONITE 810134-88AB "TWO-WAY" BLUE



ROOT CREEK WATER DISTRICT
STANDARD DETAIL

PREPARED BY: STEPHEN GRISEZ
Steph Grisez
NICK BRUNO, RCWD PRESIDENT

TYPICAL FIRE HYDRANT MARKER
LOCATIONS

SCALE: NOT TO SCALE

DATE ADOPTED: 8-12-2019

W-15

SHEET 15 OF 37

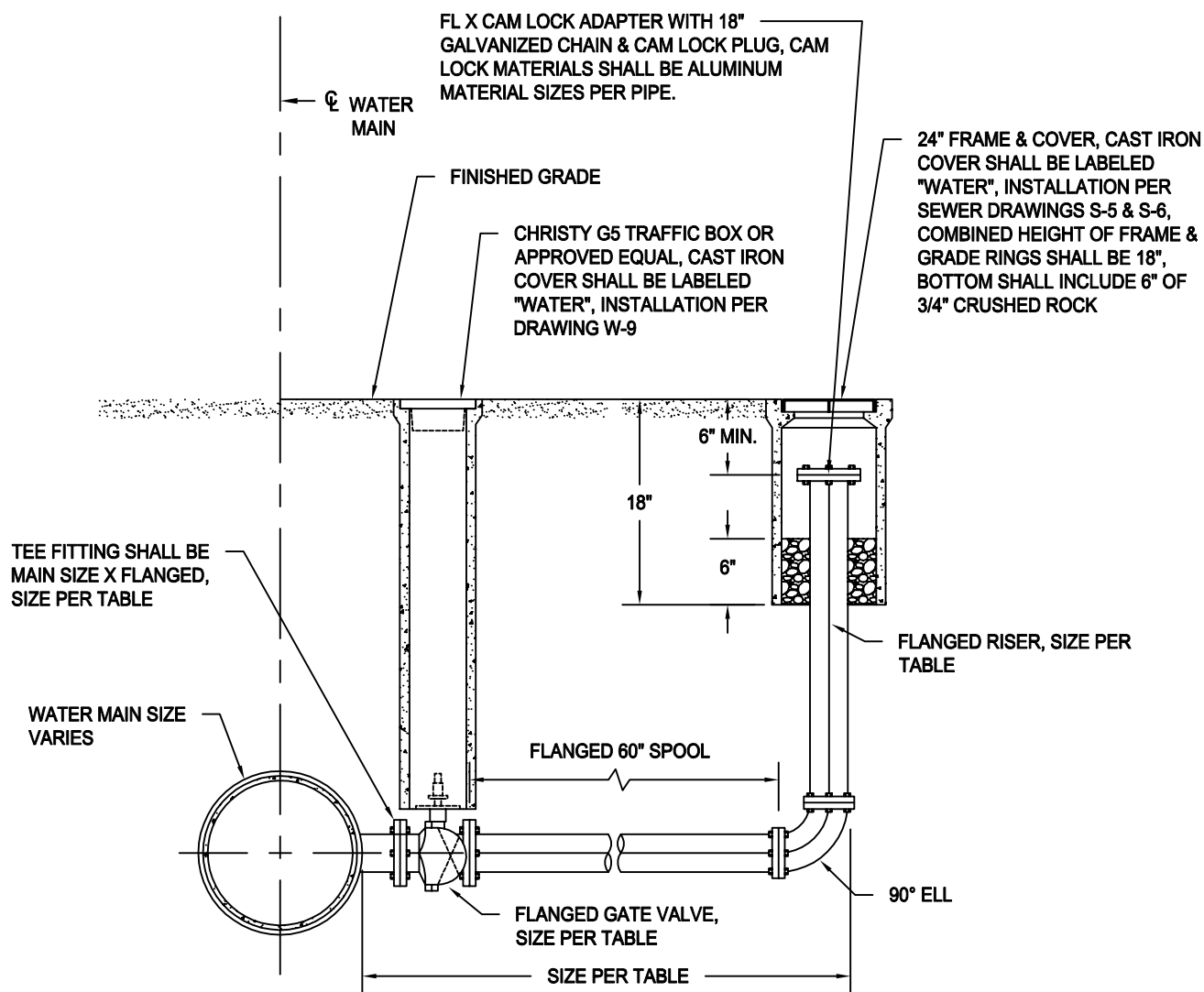

- NOTES:**
1. ALL FITTINGS SHALL BE FLANGED.
 2. PLACE VALVES AND BLOW-OFFS OUTSIDE SIDEWALK AND DRIVEWAY AREAS.
 3. ALL WATER SYSTEM MATERIALS THAT COME INTO CONTACT WITH POTABLE WATER SHALL BE ANSI/NSF STANDARD-61 CERTIFIED OR EQUIVALENT AND SHALL BE LEAD FREE.

BLOW-OFF SCHEDULE	
PIPE SIZE MAIN	BLOW-OFF
6"	4"
8"	4"
10"	4"
12"	6"
14"	6"
16" OR LARGER	8"



**ROOT CREEK WATER DISTRICT
STANDARD DETAIL**

PREPARED BY: *Stephen Grisez*
STEPHEN GRISEZ
NICK BRUNO, RCWD PRESIDENT

**BLOW-OFF ASSEMBLY
IN LINE INSTALLATION**

SCALE: NOT TO SCALE
DATE ADOPTED: 8-12-2019

W-16
SHEET 16 OF 37

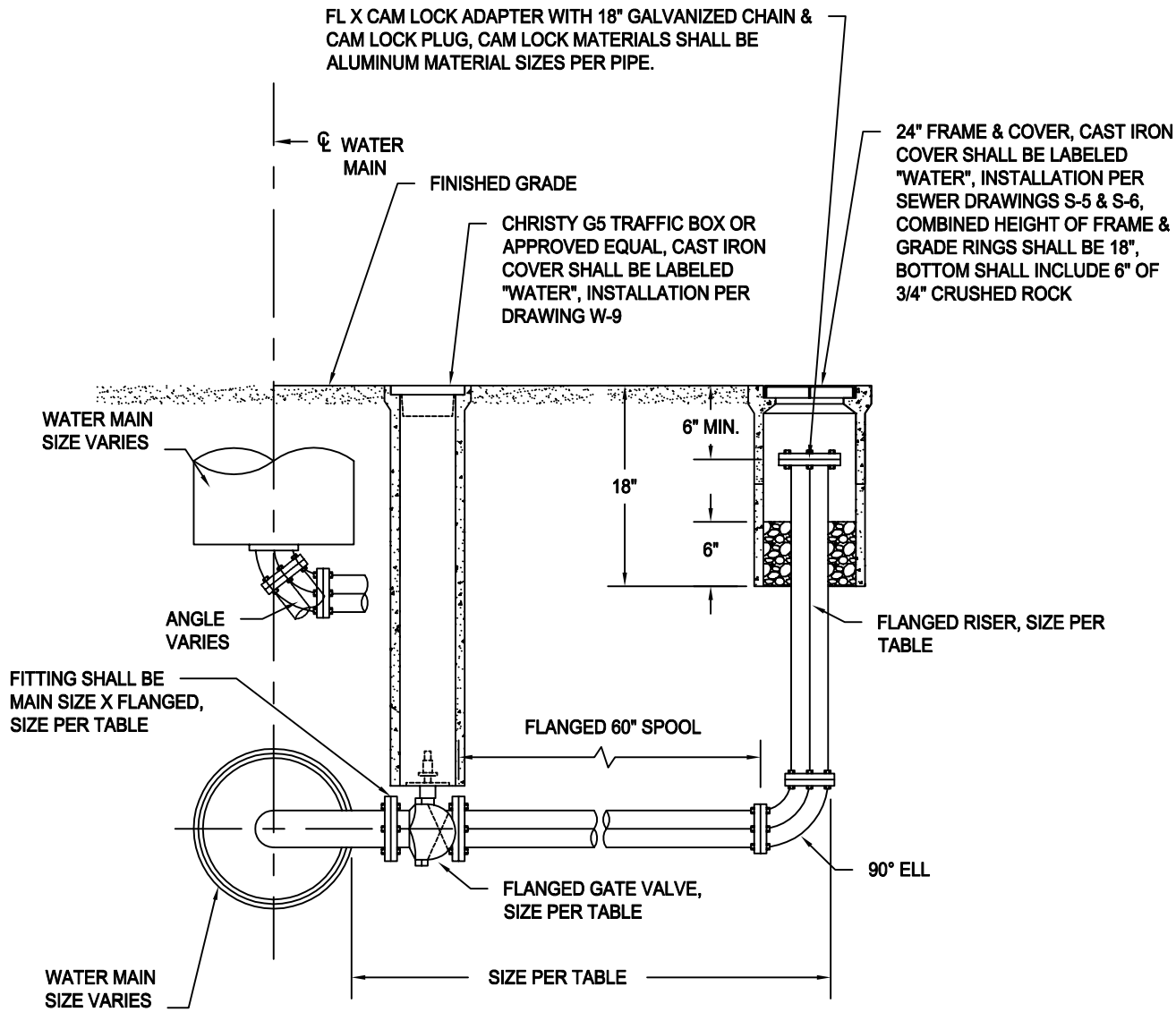

- NOTES:**
1. ALL FITTINGS SHALL BE FLANGED.
 2. PLACE VALVES AND BLOW-OFFS OUTSIDE SIDEWALK AND DRIVEWAY AREAS.
 3. ALL WATER SYSTEM MATERIALS THAT COME INTO CONTACT WITH POTABLE WATER SHALL BE ANSI/NSF STANDARD-61 CERTIFIED OR EQUIVALENT AND SHALL BE LEAD FREE.

BLOW-OFF SCHEDULE	
PIPE SIZE	
MAIN	BLOW-OFF
6"	4"
8"	4"
10"	4"
12"	6"
14"	6"
16" OR LARGER	8"



**ROOT CREEK WATER DISTRICT
STANDARD DETAIL**

PREPARED BY: *Stephen Grisez*
STEPHEN GRISEZ
NICK BRUNO, RCWD PRESIDENT

**BLOW-OFF ASSMEBLY END
OF LINE INSTALLATION**

SCALE: NOT TO SCALE
DATE ADOPTED: 8-12-2019

W-17
SHEET 17 OF 37

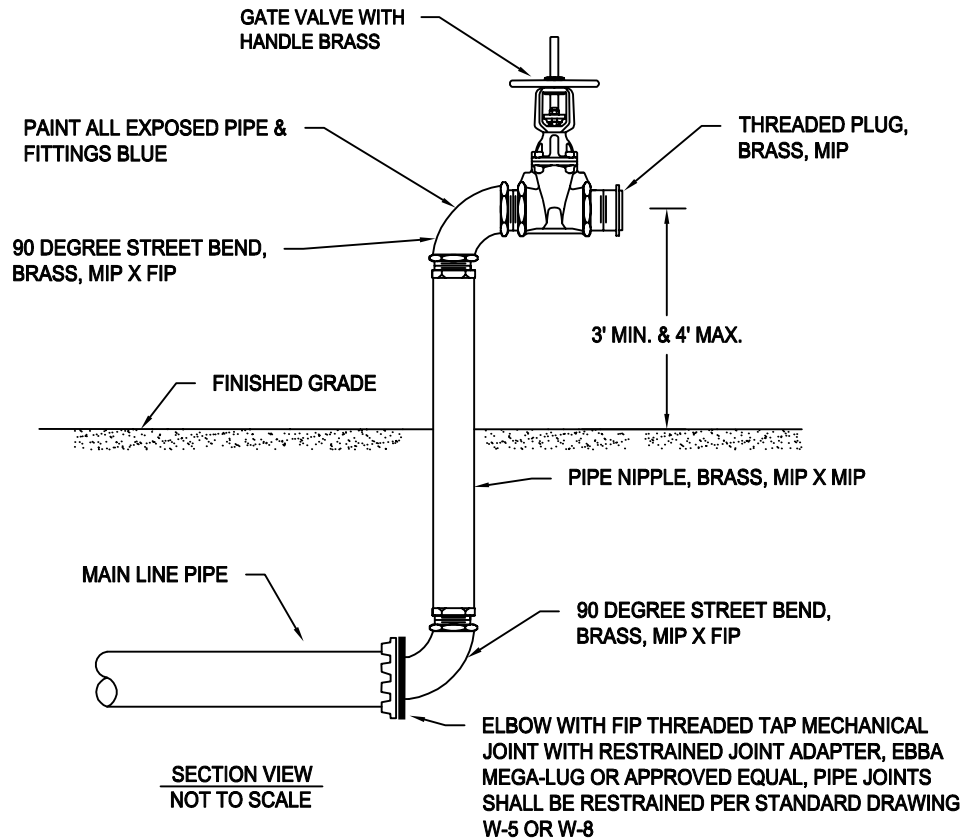

TEMPORARY BLOW-OFFS MAY BE USED AT LOCATIONS DEFINED BY ENGINEER OR CONSTRUCTION MANAGER WHERE THIS TYPE OF TEMPORARY ASSEMBLY IS APPROPRIATE.

NOTES:

1. ALL FITTINGS SHALL BE SECURED WITH RETAINING GLANDS AND HARNESSSES AS APPLICABLE.
2. PLACE VALVES AND BLOW-OFFS OUTSIDE SIDEWALK AND DRIVEWAY AREAS.
3. BRASS BLOW-OFF FITTINGS 4" OR LARGER MAY BE REPLACED WITH FLANGED DUCTILE PIPE, FITTINGS AND BLIND FLANGE (RESTRAINED JOINTS NOT PERMITTED).
4. ALL WATER SYSTEM MATERIALS THAT COME INTO CONTACT WITH POTABLE WATER SHALL BE ANSI/NSF STANDARD-61 CERTIFIED OR EQUIVALENT AND SHALL BE LEAD FREE.

BLOW-FLOW SCHEDULE	
PIPE SIZE	
MAIN	BLOW-OFF
4"	2"
6"	2"
8"	4"
10"	4"
12"	4"
14"	4"
16" OR LARGER	4"



**ROOT CREEK WATER DISTRICT
STANDARD DETAIL**

PREPARED BY: STEPHEN GRISEZ
Stephen Grisez
NICK BRUNO, RCWD PRESIDENT

**TEMPORARY BLOW OFF ASSEMBLY WITH
RESTRAINED JOINT**

SCALE: NOT TO SCALE

DATE ADOPTED: 12-9-2019

W-18

SHEET 18 OF 39

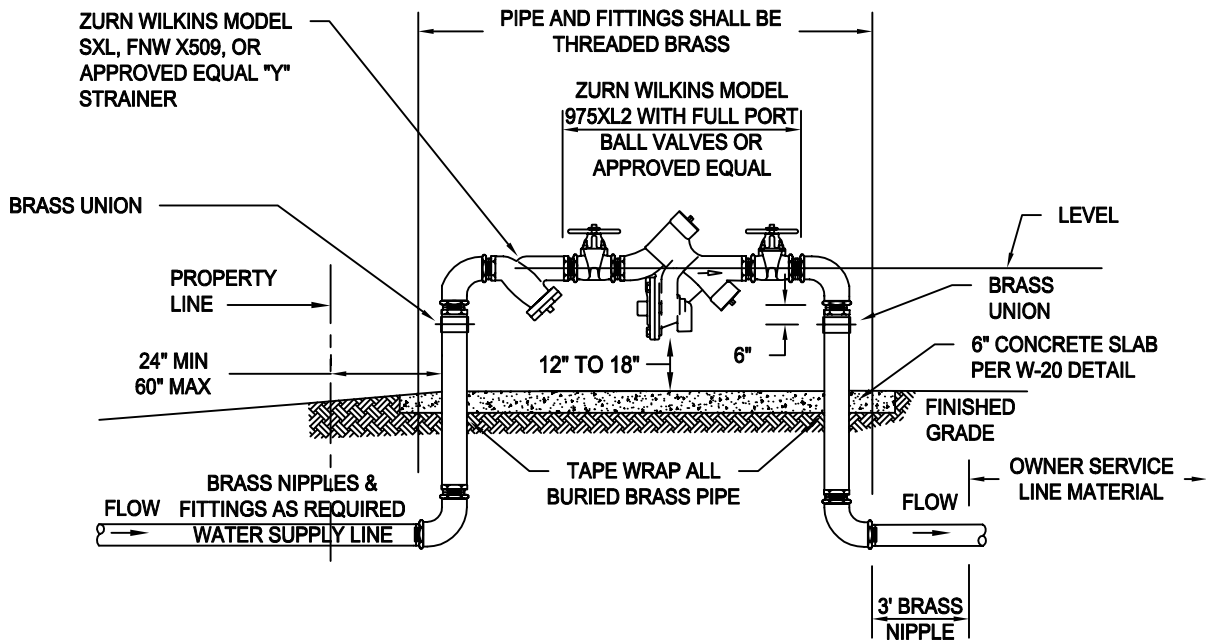

GENERAL NOTES:

1. RESILIENT SEATED SHUT OFF VALVES AND TEST COCKS ARE REQUIRED.
2. NO TAPS, TEES OR CONNECTIONS OF ANY KIND ARE PERMITTED BETWEEN THE WATER METER AND THE BACKFLOW ASSEMBLY.
3. ALL ASSEMBLIES REQUIRE INSULATION BLANKETS. INSULATION BLANKETS SHALL BE CONSTRUCTED OF THICK VINYL, HEAVILY STITCHED, INDUSTRIAL GRADE COMPRESSED FIBERGLASS WITH A R13 INSULATION VALUE, AND COLOR SHALL BE TAN.
4. ASSEMBLY MUST BE ACCESSIBLE FOR TESTING AND MAINTENANCE.
5. ASSEMBLY TO BE SAME SIZES AS THE WATER SUPPLY LINE PER UNIFORM PLUMBING CODE.
6. PRESSURE LOSS THROUGH RP ASSEMBLY MUST BE INCLUDED IN PRESSURE LOSS CALCULATIONS FOR SIZING OF THE WATER SYSTEM PER UNIFORM PLUMBING CODE.
7. INSTALL A MINIMUM OF TWO UNIONS IN THE PIPING SYSTEM WITHIN 6" INCHES OF THE ASSEMBLY.
8. DRAINAGE TO EXTERIOR OF THE BUILDING IS REQUIRED WHEN ASSEMBLY IS INSTALLED INSIDE.
9. ANY DEVIATION FROM THESE REQUIREMENTS SHALL BE APPROVED BY DISTRICT ENGINEER PRIOR TO INSTALLATION.
10. ALL ASSEMBLIES REQUIRED PROTECTIVE ENCLOSURES. PROTECTIVE ENCLOSURES AND REQUIREMENTS ARE SPECIFIED AT STANDARD DRAWING W-20.
11. 3" SIZE IS NOT USED AND SHALL BE UPGRADED TO 4" SIZE.
12. ALL WATER SYSTEM MATERIALS THAT COME INTO CONTACT WITH POTABLE WATER SHALL BE ANSI/NSF STANDARD-61 CERTIFIED OR EQUIVALENT AND SHALL BE LEAD FREE.

**1", 1.5" & 2" REDUCED PRESSURE PRINCIPLE
BACKFLOW ASSEMBLY INSTALLATION**



**ROOT CREEK WATER DISTRICT
STANDARD DETAIL**

PREPARED BY: **STEPHEN GRISEZ**
Stephen Grisez
NICK BRUNO, RCWD PRESIDENT

**1 IN, 1.5 IN & 2 IN REDUCED PRESSURE
PRINCIPLE BACKFLOW**

SCALE: NOT TO SCALE

DATE ADOPTED: 8-12-2019

W-19

SHEET 19 OF 37

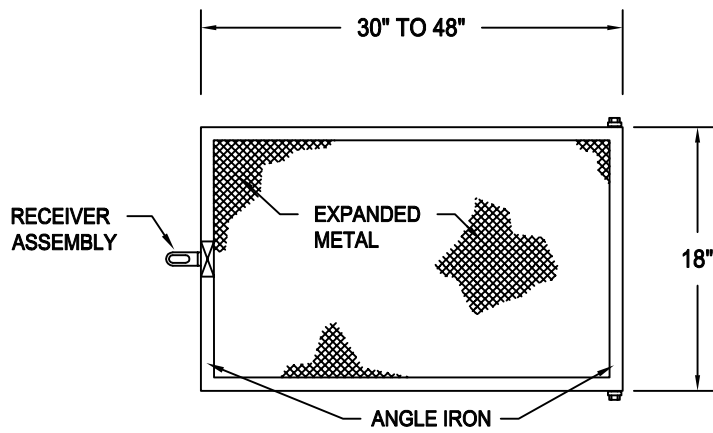

TOP VIEW

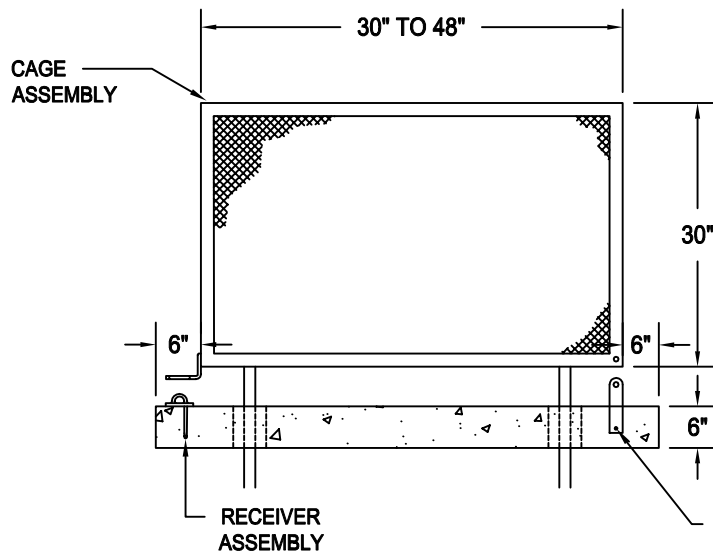

FRONT VIEW

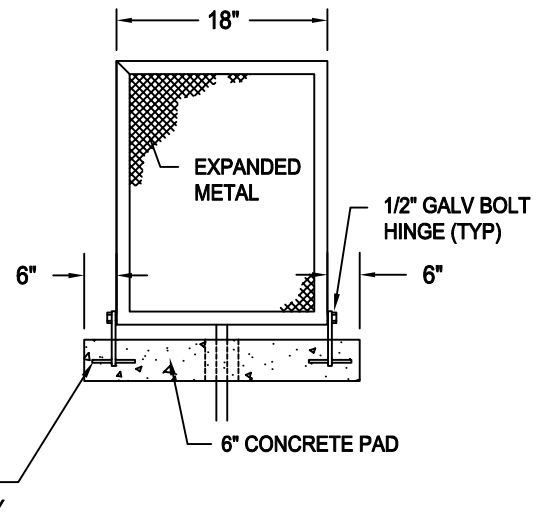

END VIEW

GENERAL NOTES:

1. ALL SPEC ENCLOSURES 1" SHALL BE BFE-3030 AND 1.5" OR 2" SHALL BE BFE-4830 ASSEMBLY SHALL BE POWDER COATED, AND COLOR SHALL BE RAL 1019 "TAN", OR APPROVED EQUAL.
2. CONCRETE SLAB SHALL BE 6" THICK, EXPOSED EDGES SHALL RECEIVE 1/2" RADIUS AND SURFACE SHALL RECEIVE A SWEAT FINISH. CONCRETE SHALL BE CLASS "A", SIX-SACK MIX.
3. ALL PIPING THROUGH CONCRETE SHALL BE DOUBLE WRAPPED WITH 20 MIL PLUMBERS TAPE.
4. ALL PIPING THROUGH CONCRETE SHALL BE PROTECTED BY A PVC, SCHEDULE 40 SLEEVE THAT IS TWICE THE SIZE OF PIPING.



**ROOT CREEK WATER DISTRICT
STANDARD DETAIL**

PREPARED BY: STEPHEN GRISEZ
Stephen Grisez
NICK BRUNO, RCWD PRESIDENT

**TYPICAL ENCLOSURE FOR BACKFLOW
PREVENTION DEVICES**

SCALE: NOT TO SCALE

DATE ADOPTED: 8-12-2019

W-20

SHEET 20 OF 37

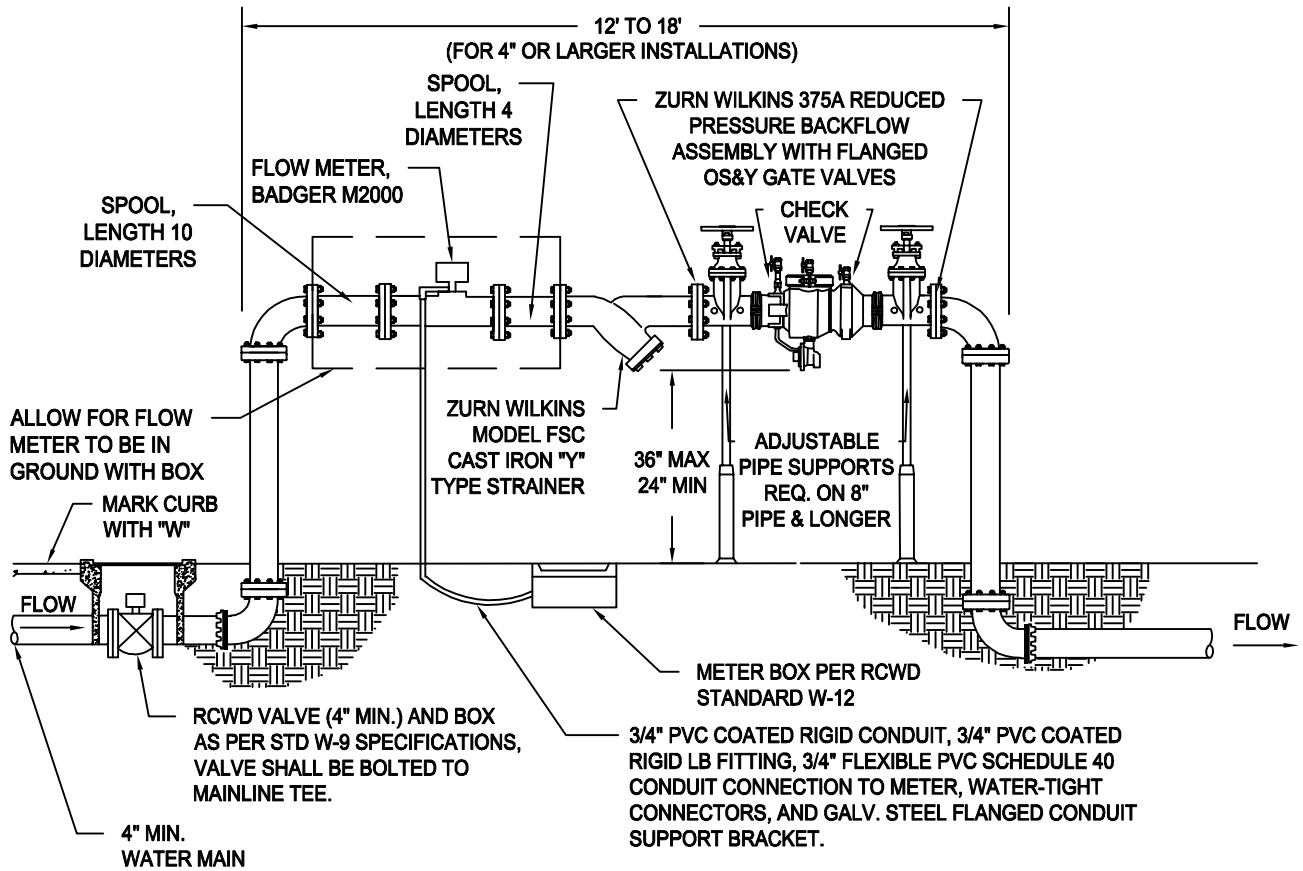

NOTES:

1. REFER TO MANUFACTURER'S CATALOG FOR CORRECT DIMENSIONS TO FIT SIZE OF SPECIFIED BACKFLOW
2. AN APPROVED BACKFLOW PREVENTION ASSEMBLY SHALL BE INSTALLED ON EACH SERVICE LINE TO CUSTOMERS WATER SYSTEM AT OR NEAR THE PROPERTY LINE.
3. ALL PIPE AND FITTINGS SHALL BE DUCTILE IRON AND ABOVE GRADE SHALL BE FLANGED AND BELOW GRADE SHALL BE MECHANICAL JOINT WITH RESTRAINED JOINT ADAPTERS, EBAA MEGALUG OR APPROVED EQUAL. BELOW GRADE PIPE JOINTS SHALL BE RESTRAINED PER STANDARD DRAWING W-3 OR W-4.
4. ALL ASSEMBLIES SHALL BE PRIMED AND PAINTED WITH A RUST PREVENTATIVE PAINT. COLOR SHALL BE SHERWIN WILLIAMS SW6106 KILIM BEIGE.
5. OPERATIONAL PRESSURES: ROOT CREEK WATER DISTRICT NORMAL OPERATING PRESSURE OF 50 PSI. PRESSURE WILL VARY WITH LOCATION WITHIN SYSTEM.
6. WATER METER & TRANSMITTER ASSEMBLY:
 - A. MANUFACTURER: BADGER
 - B. MODEL NUMBER: ORION 3G
 - C. UNIT: CUBIC FEET
 - D. INSTALLATION: METER & TRANSMITTER SHALL BE INSTALLED BY ROOT CREEK WATER DISTRICT
7. ALL WATER SYSTEM MATERIALS THAT COME INTO CONTACT WITH POTABLE WATER SHALL BE ANSI/NSF STANDARD-61 CERTIFIED OR EQUIVALENT AND SHALL BE LEAD FREE.



**ROOT CREEK WATER DISTRICT
STANDARD DETAIL**

PREPARED BY: STEPHEN GRISEZ
Stephen Grisez
NICK BRUNO, RCWD PRESIDENT

**4 IN & LARGER STANDARD
METER-BACKFLOW INSTALLATION**

SCALE: NOT TO SCALE

DATE ADOPTED: 7-13-2020

W-21

SHEET 21 OF 39

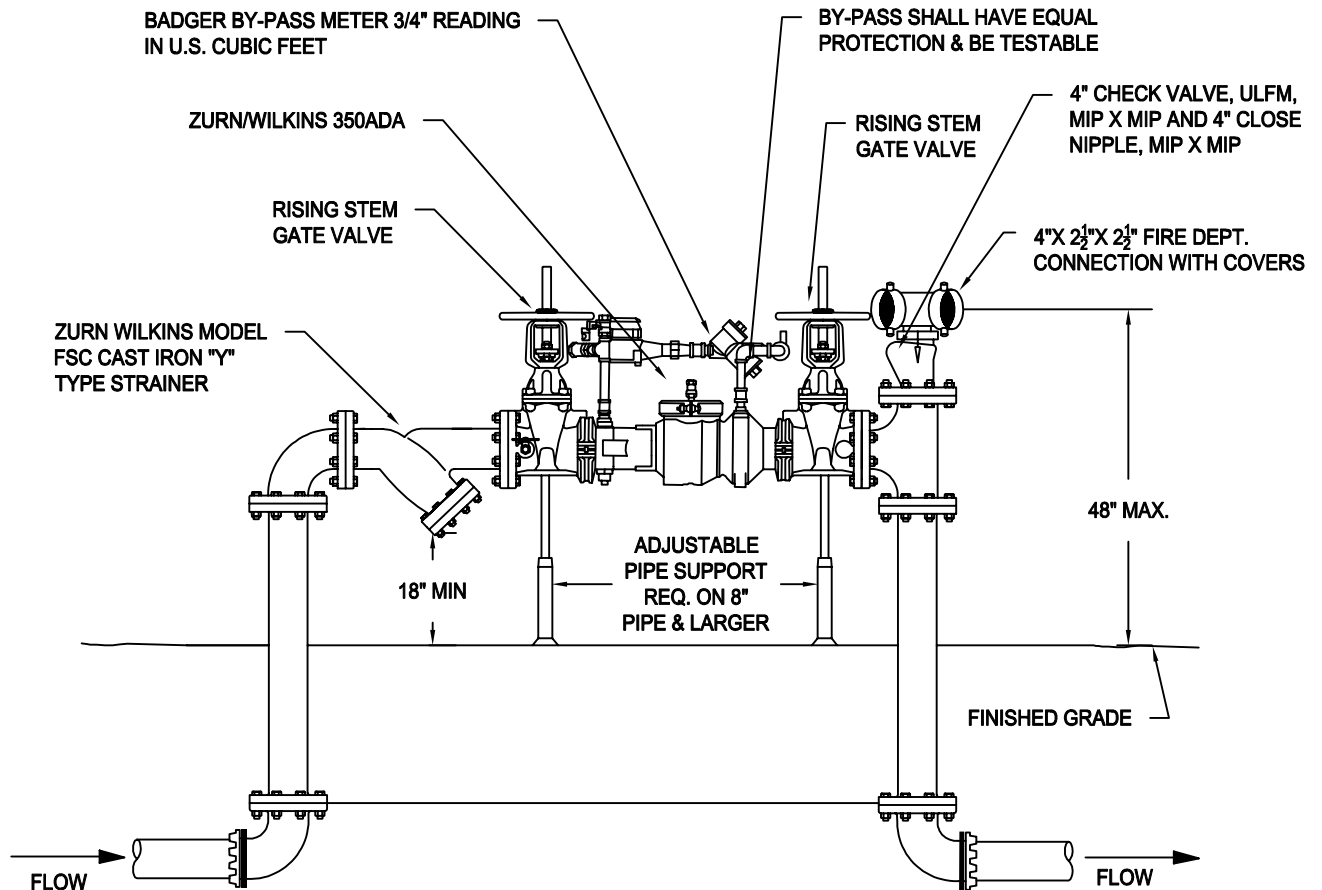

NOTES:

1. ALL PIPE AND FITTINGS SHALL BE DUCTILE IRON AND ABOVE GRADE SHALL BE FLANGED AND BELOW GRADE SHALL BE MECHANICAL JOINT WITH RESTRAINED JOINT ADAPTERS. BELOW GRADE PIPE JOINTS SHALL BE RESTRAINED PER STANDARD DRAWING W-3 OR W-4.
2. METER AND VALVES SHALL MEET DISTRICT AND A.W.W.A. STANDARDS.
3. BACKFLOW DEVICES SHALL BE A DOUBLE CHECK DETECTOR ASSEMBLY. MAINTAIN 18" CLEARANCE AROUND PERIMETER OF DEVICE.
4. FIRE HYDRANT SHALL NOT BE LOCATED BETWEEN F.D.C. AND BUILDINGS.
5. FIRE HYDRANT SHALL BE LOCATED 100 FEET OR LESS FROM F.D.C.
6. THREE FEET CLEARANCE SHALL BE MAINTAINED AROUND F.D.C.
7. ALL ASSEMBLIES SHALL BE PRIMED AND PAINTED WITH A RUST PREVENTIVE PAINT. COLOR SHALL BE SHERWIN WILLIAMS SW6106 KILIM BEIGE.
8. ALL WATER SYSTEM MATERIALS THAT COME INTO CONTACT WITH POTABLE WATER SHALL BE ANSI/NSF STANDARD-61 CERTIFIED OR EQUIVALENT AND SHALL BE LEAD FREE.

OPERATION PRESSURES:

ROOT CREEK WATER DISTRICT NORMAL OPERATING PRESSURE OF 50PSI. PRESSURE WILL VARY WITH LOCATION WITHIN SYSTEM.



**ROOT CREEK WATER DISTRICT
STANDARD DETAIL**

PREPARED BY: STEPHEN GRISEZ
Stephen Grisez
NICK BRUNO, RCWD PRESIDENT

FIRE-LINE INSTALLATION

SCALE: NOT TO SCALE

DATE ADOPTED: 8-12-2019

W-22

SHEET 22 OF 37

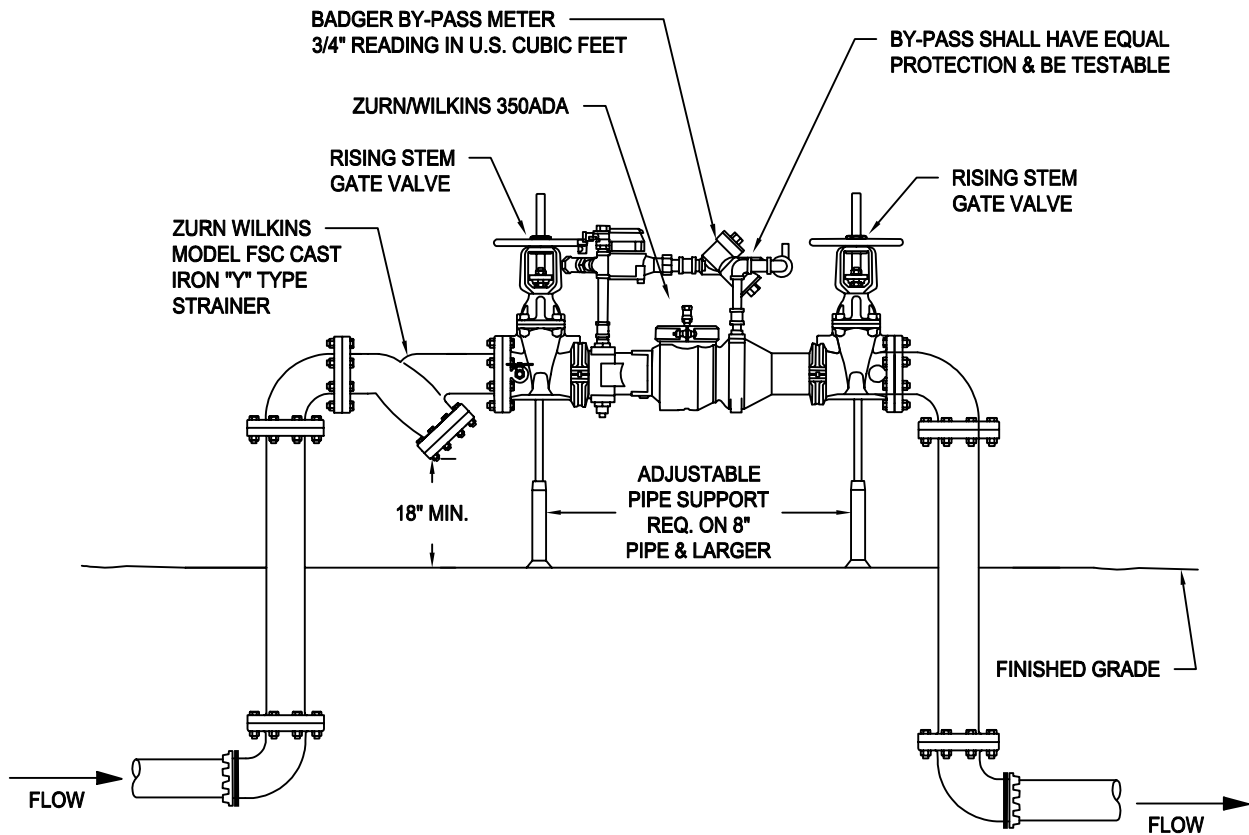

NOTES:

1. ALL PIPE AND FITTINGS SHALL BE DUCTILE IRON AND ABOVE GRADE SHALL BE FLANGED AND BELOW GRADE SHALL BE MECHANICAL JOINT WITH RESTRAINED JOINT ADAPTERS. BELOW GRADE PIPE JOINTS SHALL BE RESTRAINED PER STANDARD DRAWING W-3 OR W-4.
2. METER AND VALVES SHALL MEET RCWD AND A.W.W.A. STANDARDS.
3. BACKFLOW DEVICES SHALL BE A DOUBLE CHECK DETECTOR ASSEMBLY.
4. MAINTAIN 18" CLEARANCE AROUND PERIMETER OF DEVICE.
5. FIRE HYDRANT SHALL BE LOCATED 100 FEET OR LESS FROM F.D.C OR LESS.
6. THREE FEET CLEARANCE SHALL BE MAINTAINED AROUND F.D.C.
7. USE THIS DETAIL WITHOUT F.D.C. WHEN HYDRANT DOWN STREAM OF F.D.C.
8. F.D.C. LOCATION TO BE APPROVED BY ROOT CREEK WATER DISTRICT.
9. ALL ASSEMBLIES SHALL BE PRIMED AND PAINTED WITH A RUST PREVENTIVE PAINT. COLOR SHALL BE SHERWIN WILLIAMS SW6106 KILIM BEIGE.
10. ALL WATER SYSTEM MATERIALS THAT COME INTO CONTACT WITH POTABLE WATER SHALL BE ANSI/NSF STANDARD-61 CERTIFIED OR EQUIVALENT AND SHALL BE LEAD FREE.

OPERATION PRESSURES:

ROOT CREEK WATER DISTRICT NORMAL OPERATING PRESSURE OF 50PSI. PRESSURE WILL VARY WITH LOCATION WITHIN SYSTEM.



**ROOT CREEK WATER DISTRICT
STANDARD DETAIL**

PREPARED BY: STEPHEN GRISEZ
Stephen Grisez
NICK BRUNO, RCWD PRESIDENT

**FIRE-LINE INSTALLATION
WITHOUT - FDC**

SCALE: NOT TO SCALE

DATE ADOPTED: 8-12-2019

W-23

SHEET 23 OF 37

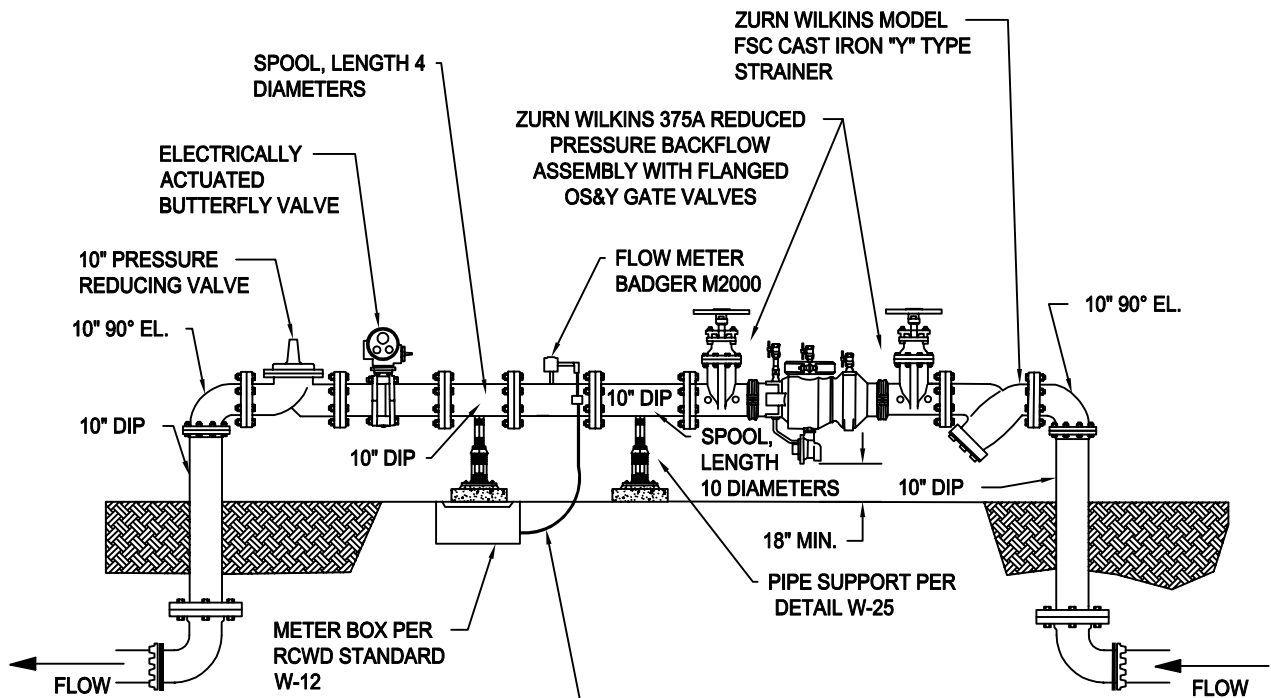

3/4" PVC COATED RIGID CONDUIT, 3/4" PVC COATED RIGID LB FITTING, 3/4" FLEXIBLE PVC SCHEDULE 40 CONDUIT CONNECTION TO METER, WATER-TIGHT CONNECTORS, AND GALV. STEEL FLANGED CONDUIT SUPPORT BRACKET.

OPERATION PRESSURES:

ROOT CREEK WATER DISTRICT NORMAL OPERATING PRESSURE OF 50 PSI. PRESSURE WILL VARY BY LOCATION WITHIN SYSTEM.

NOTES:

1. ALL PIPE AND FITTINGS SHALL BE DUCTILE IRON AND ABOVE GRADE SHALL BE FLANGED AND BELOW GRADE SHALL BE MECHANICAL JOINT WITH RESTRAINED JOINT ADAPTERS. BELOW GRADE PIPE JOINTS SHALL BE RESTRAINED PER STANDARD DRAWING W-3 OR W-4.
2. METER AND VALVES SHALL MEET RCWD AND A.W.W.A. STANDARDS.
3. BACKFLOW DEVICES SHALL BE REDUCED PRESSURE BACKFLOW PREVENTER
4. MAINTAIN 18" CLEARANCE AROUND PERIMETER OF DEVICE.
5. ALL ASSEMBLIES SHALL BE PRIMED AND PAINTED WITH A RUST PREVENTIVE PAINT. COLOR SHALL BE SHERWIN WILLIAMS SW6106 KILIM BEIGE.
6. WATER METER & TRANSMITTER ASSEMBLY:
 - A. MANUFACTURER: BADGER
 - B. MODEL NUMBER: ORION 3G
 - C. UNITS: CUBIC FEET
 - D. INSTALLATION: METER & TRANSMITTER SHALL BE INSTALLED BY ROOT CREEK WATER DISTRICT
7. ALL WATER SYSTEM MATERIALS THAT COME INTO CONTACT WITH POTABLE WATER SHALL BE ANSI/NSF STANDARD-61 CERTIFIED OR EQUIVALENT AND SHALL BE LEAD FREE.



**ROOT CREEK WATER DISTRICT
STANDARD DETAIL**

10 IN AG. TURNOUT

PREPARED BY: STEPHEN GRISEZ
Steph Grisez
NICK BRUNO, RCWD PRESIDENT

SCALE: NOT TO SCALE

DATE ADOPTED: 8-12-2019

W-24

SHEET 24 OF 37

DIMENSIONS				
PIPE SIZE	"A"	"B"	"C"	
			MIN	MAX
2 1/2"	2 1/2"	1 1/2"	8"	13"
3"	2 1/2"	1 1/2"	8 1/4"	13 1/4"
4"	3"	2 1/2"	9 1/4"	14"
6"	3"	2 1/2"	10 1/2"	15 1/4"
8"	3"	2 1/2"	11 3/4"	16 1/2"
10"	3"	2 1/2"	13 1/2"	18 1/4"
12"	3"	2 1/2"	15"	19 3/4"

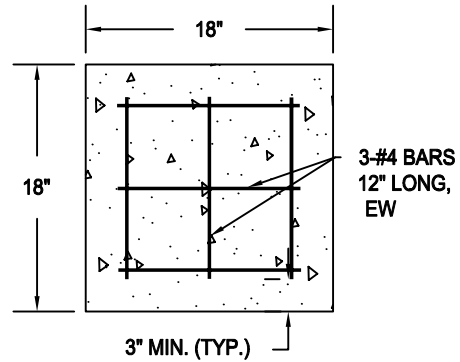
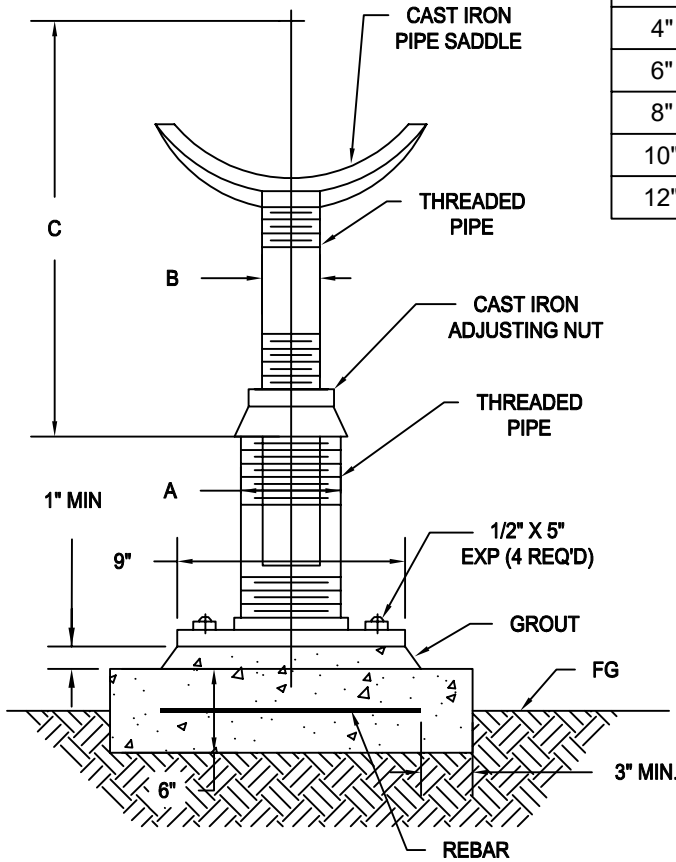

NOTE: FOR SUPPORTS IN AREAS OUTSIDE OF FLOOR SLAB, CONSTRUCT 18\"/>

NOTES:

1. ALL PIPE SHALL BE HOT DIP GALVANIZED.
2. ANCHORS, WASHERS, AND NUTS SHALL BE 304 OR 316 STAINLESS STEEL.



ROOT CREEK WATER DISTRICT
STANDARD DETAIL

PIPE SUPPORT

PREPARED BY: STEPHEN GRISEZ
Stephen Grisez
NICK BRUNO, RCWD PRESIDENT

SCALE: NOT TO SCALE

DATE ADOPTED: 8-12-2019

W-25

SHEET 25 OF 37

WATER SERVICE TRENCH NOTE:

NO LIME OR CEMENT-TREATED SOILS ALLOWED WITHIN 12" OF THE WATER SERVICE LINE. FOR INSTALLATIONS WHERE LIME OR CEMENT-TREATED SOILS ARE PRESENT, BACKFILL THE SERVICE LINE WITH CLEAN SOILS MEETING THE STANDARD FOR IMPORTED BACKFILL MATERIAL PER DISTRICT STANDARD SPECIFICATIONS SECTION 17.3.2.

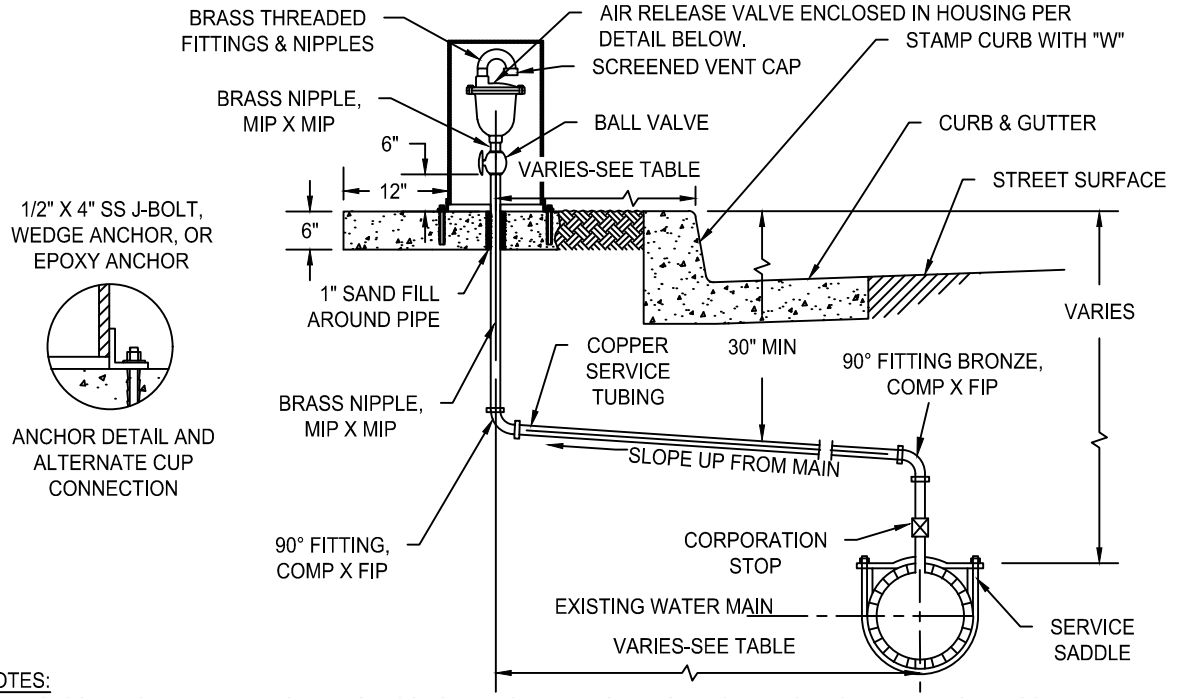

NOTES:

- ENCLOSURE SHALL BE ATTACHED TO A CONCRETE SLAB MEASURING 12" ON ALL SIDES AND 6" THICK. IF COMBINED WITH OTHER SERVICES OR APPURTENANCES IN A SINGLE PAD THE PAD SHALL INCLUDE DEEP SCORE JOINTS BETWEEN EACH ASSEMBLY, EXPOSED EDGES SHALL RECEIVE 1/4" RADIUS AND SURFACE SHALL RECEIVE A SWEAT FINISH.
- COPPER TUBING SHALL INCLUDE HDPE COATING OR POLYBAG.
- 1" & 2" SADDLES - PVC C900 McDONALD 3855 & PVC C905 McDONALD 3845B OR FORD 202BSD-xxx-TAP OR APPROVED EQUAL.
- 1" & 2" CORP STOPS - McDONALD NL BALL STYLE CORP STOPS - 73128B OR FORD BALLCORP CORP STOP - FB400-X-NI STYLE.
- 1" & 2" 90 DEGREE BENDS - McDONALD NL SERVICE FITTING - 74779Q OR FORD PACK JOINT ELL COUPLING - L14-XX-NL STYLE.
- 1" OR 2" TYPE "K" SOFT DRAWN COPPER TUBING WITH PLASTIC COATING, STREAMLINE OR APPROVED EQUAL, RUNS LONGER THAN 20' SHALL BE UNCOATED AND INSTALLED IN HDPE POLYBAG, ALL EXPOSED COPPER SHALL BE TAPE WRAPPED.
- 1" OR 2" BRASS NIPPLE, MIP X MIP, LEAD FREE.
- 1" OR 2" FNW BRASS BODY BALL VALVE, MODEL X410C, FIP X FIP.
- ARV - VAL-MATIC 1" MODEL 201C.2 & 2" MODEL 202C.2 .
- AIR VENT CAPS - CHRISTY 1" MODEL VC1, 2" MODEL VC2 .
- COVER PIPELINE PRODUCTS 1" MODEL VROOT1630E, 2" MODEL V-ROOT-2430E
- ALL NUTS, BOLTS, & WASHERS SHALL BE 304 OR 316 STAINLESS STEEL.
- ALL WATER SYSTEM MATERIALS THAT COME INTO CONTACT WITH POTABLE WATER SHALL BE ANSI/NSF STANDARD-61 CERTIFIED OR EQUIVALENT AND SHALL BE LEAD FREE.
- ARV VALUES SHOULD BE LOCATED WHERE POSSIBLE AT THE HIGH POINT OF THE TRACT ENTRANCE DOWN STREAM OF THE VALVE FROM THE MAIN PIPELINE, AND ± 50' CLEAR OF INTERSECTIONS WHERE POSSIBLE.

ARV. ENCLOSURE SIZES:

1" WATER ARV ENCLOSURE 16" DIAMETER X 30" HEIGHT		
2" WATER ARV ENCLOSURE 24" DIAMETER X 30" HEIGHT		
LOCATIONS:	1" WATER ARV	2" WATER ARV
EDGE OF PAVEMENT - TO CENTER OF ARV SHALL BE (PROVIDES 24" FROM EP TO BOLLARDS.) FG SHALL BE 2" ABOVE EP GRADE.	56" *	60" *
C&G OR AC DIKE AREA WITH NO SIDEWALKS - FACE OF CURB TO CENTER OR ARV SHALL BE	32" *	36" *
C&G AND SEPARATED SIDEWALK - BACK OF SIDEWALK TO CENTER OF ARV SHALL BE	32"	36"
C&G AND MONOLITHIC SIDEWALK - BACK OF SIDEWALK TO CENTER OF ARV SHALL BE	32"	36"
	* NOTE: OR AS DIRECTED BY OWNER/RCWD	
NOTES:		
1. THE SPECIFIED ARV DIMENSIONS WILL CAUSE 12" CLEAR SPACE BEHIND SIDEWALK, 12" ARV SLAB, AND FACE OF ARV ENCLOSURE. (FACE OF ARV ENCLOSURE WILL BE 2' BEHIND BACK OF SIDEWALK)		

	<p align="center">ROOT CREEK WATER DISTRICT STANDARD DETAIL</p>	<p align="center">1 IN & 2 IN AUTOMATIC AIR RELEASE AND VACUUM VALVE - ARV</p>	
	<p>PREPARED BY: STEPHEN GRISEZ</p> <p>NICK BRUNO, RCWD PRESIDENT</p>	<p>SCALE: NOT TO SCALE</p> <p>DATE ADOPTED: 12-8-2025</p>	<p align="center">W-26</p> <p align="right">SHEET 26 OF 39</p>

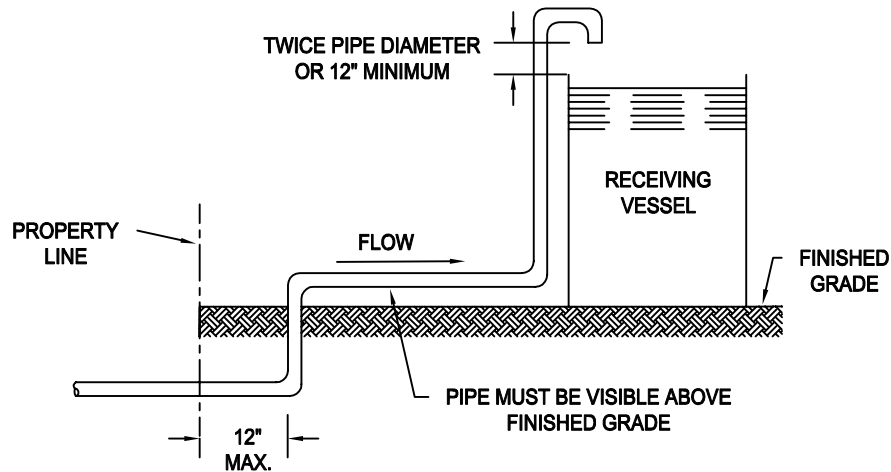

REQUIREMENTS

1. NO TAPS, TEES OR CONNECTIONS OF ANY KIND ARE PERMITTED BETWEEN THE WATER METER AND RECEIVING VESSEL.
2. THE SERVICE PIPE BETWEEN THE WATER METER AND RECEIVING VESSEL MUST BE VISIBLE ABOVE FINISHED GRADE FROM 12 INCHES BEHIND PROPERTY LINE TO THE RECEIVING VESSEL.
3. PROTECTION FROM FREEZE DAMAGE MAY BE NECESSARY IN EXPOSED AREAS.
4. ALL WATER SYSTEM MATERIALS THAT COME INTO CONTACT WITH POTABLE WATER SHALL BE ANSI/NSF STANDARD-61 CERTIFIED OR EQUIVALENT AND SHALL BE LEAD FREE.



**ROOT CREEK WATER DISTRICT
STANDARD DETAIL**

PREPARED BY: *Stephen Grisez*
STEPHEN GRISEZ
NICK BRUNO, RCWD PRESIDENT

**INSTALLATION REQUIREMENTS FOR
APPROVED AIR GAP SEPERATION**

SCALE: NOT TO SCALE

DATE ADOPTED: 8-12-2019

W-27

SHEET 27 OF 37

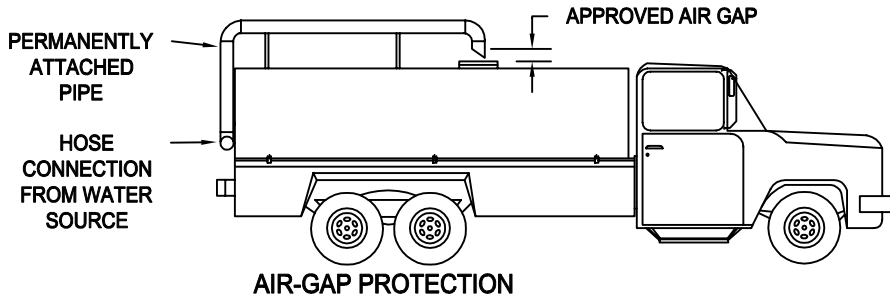

AIR-GAP PROTECTION

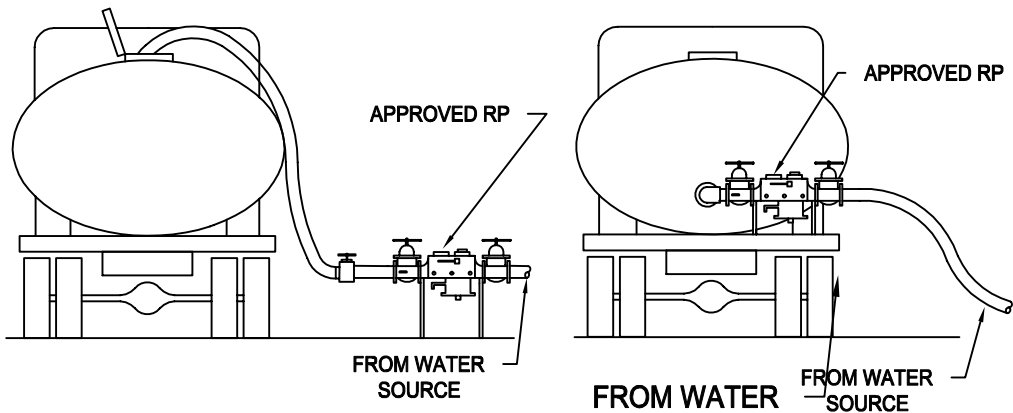

MECHANICAL ASS'Y PROTECTION SOURCE

REQUIREMENTS

1. AIR-GAP MUST BE APPROVED "AIR-GAP" SYSTEM PER 3CCR 6610.
2. MECHANICAL BACKFLOW PREVENTER MUST BE AN APPROVED REDUCED PRESSURE PRINCIPAL ASSEMBLY.
3. BACKFLOW ASSEMBLY MUST BE TESTED BY CERTIFIED BACKFLOW PREVENTION DEVICE TESTER. THE TESTS SHALL BE PERFORMED ONCE A YEAR. THE TEST RESULTS MUST BE PROVIDED TO ROOT CREEK WATER DISTRICT.
4. TYPICAL EQUIPMENT: WATER TRUCKS, PEST CONTROL TRUCKS, HYDROSEEDING EQUIPMENT, PORTABLE WASHING AND STEAM CLEANING EQUIPMENT.
5. ALL WATER SYSTEM MATERIALS THAT COME INTO CONTACT WITH POTABLE WATER SHALL BE ANSI/NSF STANDARD-61 CERTIFIED OR EQUIVALENT AND SHALL BE LEAD FREE.



**ROOT CREEK WATER DISTRICT
STANDARD DETAIL**

PREPARED BY: STEPHEN GRISEZ
Steph Grisez
NICK BRUNO, RCWD PRESIDENT

**APPROVED PORTABLE WATER
TRANSPORT BACKFLOW PROTECTION**

SCALE: NOT TO SCALE
DATE ADOPTED: 8-12-2019

W-28
SHEET 28 OF 37

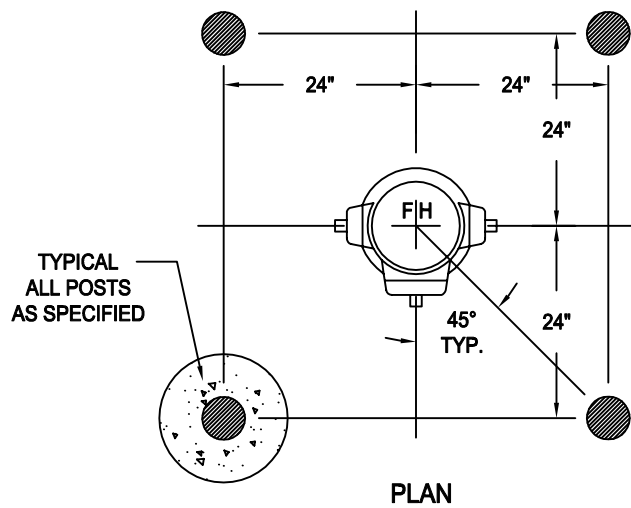

PLAN

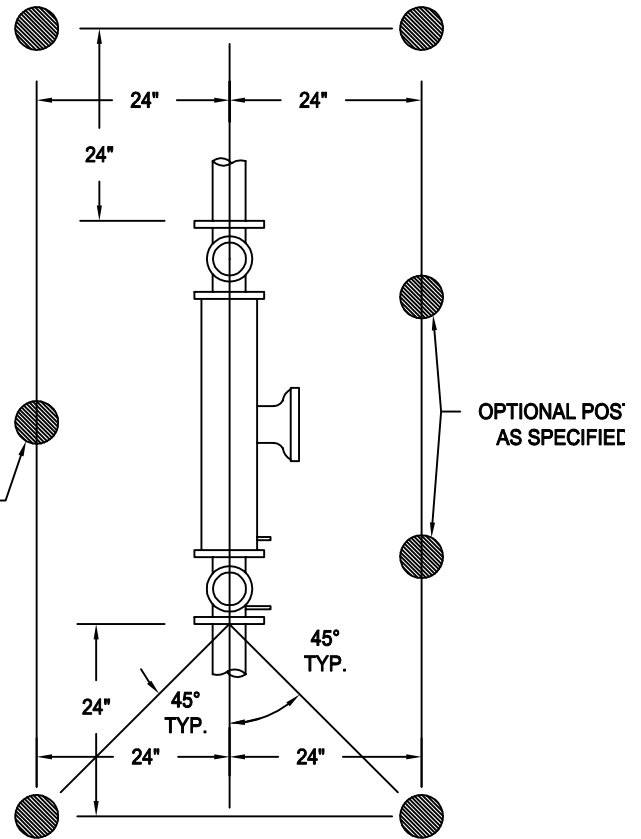

PLAN

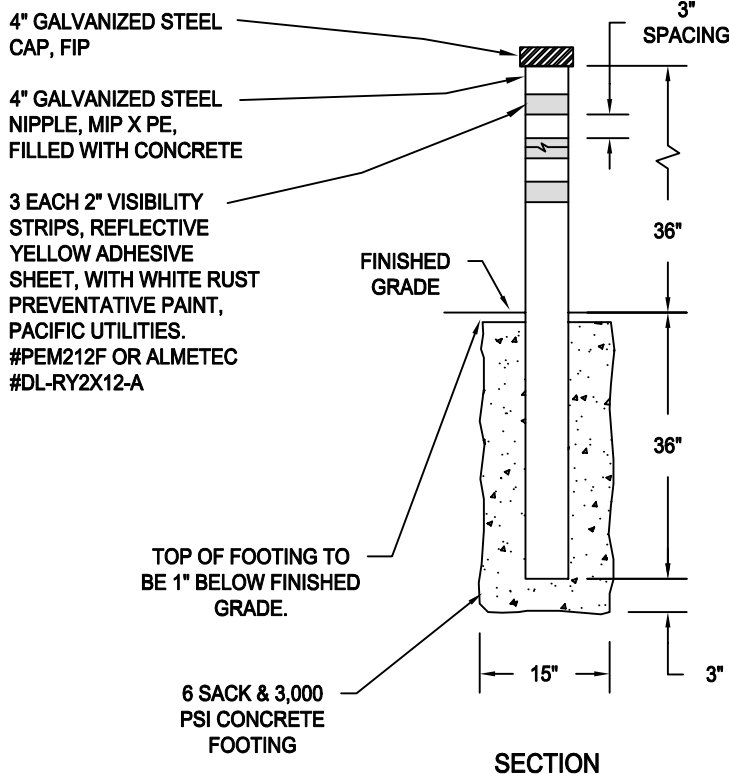

SECTION

NOTES

1. NUMBER OF POSTS SHALL BE AS SPECIFIED TO FIT VARIOUS FIELD CONDITIONS.
2. POSTS MAY BE USED IN VARIOUS LOCATIONS TO PROTECT FIRE HYDRANTS, BACKFLOW DEVICES AND OTHER ABOVE GROUND EQUIPMENT AS REQUIRED.
3. POST SHALL NOT BE PAINTED.
4. THIS STANDARD IS MEANT TO BE SIMILAR TO PG&E STANDARD GUARD POSTS.



**ROOT CREEK WATER DISTRICT
STANDARD DETAIL**

PREPARED BY: STEPHEN GRISEZ
NICK BRUNO, RCWD PRESIDENT

GUARD POST DETAILS

SCALE: NOT TO SCALE

DATE ADOPTED: 8-12-2019

W-29

SHEET 29 OF 37

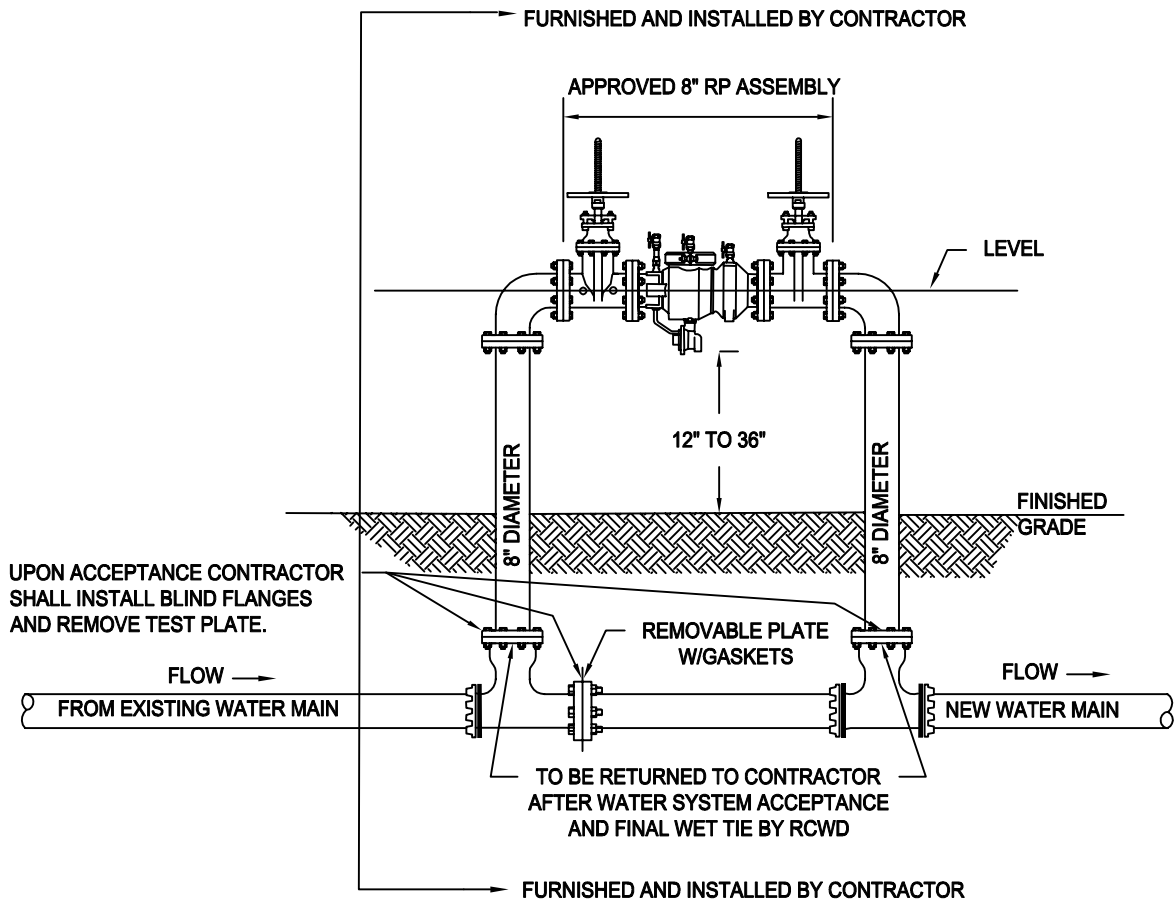

GENERAL NOTES:

1. VALVES SHALL BE "ULFM INDICATING OS&Y" TYPE.
CURRENTLY APPROVED RP DEVICES ARE:
AMES MAXIM 400
WILKINS 375A
FEBCO LF860
2. RESILIENT SEATED SHUT OFF VALVES AND TEST COCKS ARE REQUIRED.
3. ASSEMBLY MUST BE ACCESSIBLE FOR TESTING AND MAINTENANCE BY CONTRACTOR WITH INSPECTION BY ROOT CREEK WATER DISTRICT REPRESENTATIVE.
4. ANY DEVIATION FROM THESE REQUIREMENTS SHALL BE APPROVED BY THE DISTRICT ENGINEER.
5. RP DEVICE WITH ASSOCIATED PIPING, VALVES, TEES AND FITTINGS SHALL BE FURNISHED AND INSTALLED BY CONTRACTOR.
6. NEW SYSTEM OF MAINS, HYDRANTS AND SERVICES SHALL BE PRESSURE TESTED AND SHALL PASS STANDARD BACTERIAL TESTING PRIOR TO CONNECTION TO EXISTING DISTRICT WATER SYSTEM.
7. WET TIE TO EXISTING SYSTEM SHALL BE PERFORMED BY CONTRACTOR.
8. AFTER INSTALLATION AND PRIOR TO PLACING IN SERVICE, THE RP DEVICE SHALL BE TESTED BY THE CONTRACTOR.
9. PRIOR TO FINAL ACCEPTANCE OF THE WATER SYSTEM, A FINAL SET OF PRESSURE TESTS AND BACTERIAL TESTS SHALL BE PERFORMED BY CONTRACTOR.
10. UPON RECEIPT OF WRITTEN PRESSURE TEST AND BACTERIA TEST RESULTS AND WRITTEN DISTRICT ACCEPTANCE OF THE COMPLETE WATER SYSTEM, CONTRACTOR UNDER DIRECT SUPERVISION OF ROOT CREEK WATER DISTRICT REPRESENTATIVE SHALL REMOVE THE RP DEVICE AND ASSOCIATED PIPING & VALVES.
11. ALL WORK DONE PURSUANT TO THIS STANDARD DRAWING SHALL BE ACCOMPLISHED WITH DIRECT INSPECTION BY DISTRICT ENGINEER.
12. TEES SHALL BE MxJFL. RESTRAINED JOINT ADAPTERS SHALL BE EBAA MEGALUG OR APPROVED EQUAL.
13. ALL WATER SYSTEM MATERIALS THAT COME INTO CONTACT WITH POTABLE WATER SHALL BE ANSI/NSF STANDARD-61 CERTIFIED EQUIVALENT AND SHALL BE LEAD FREE.



**ROOT CREEK WATER DISTRICT
STANDARD DETAIL**

PREPARED BY: STEPHEN GRISEZ
Stephen Grisez
NICK BRUNO, RCWD PRESIDENT

**TEMPORARY RP PRINCIPLE
BACKFLOW ASSEMBLY INSTALLATION**

SCALE: NOT TO SCALE

DATE ADOPTED: 8-12-2019

W-30

SHEET 30 OF 37

SPECIFICATIONS

1. THIS STANDARD IS NOT ALLOWED WITHIN THE TRAVELED WAY OR ANY PAVED AREAS OF A PUBLIC STREET.
2. NO LESS THAN 12 FEET OF HORIZONTAL SEPARATION SHALL BE MAINTAINED BETWEEN THE MONITORING WELL AND ANY EXISTING UNDERGROUND UTILITY.
3. THE WELL BOX SHALL BE STRUCTURALLY SOUND AND STRONG ENOUGH TO SUPPORT VEHICULAR TRAFFIC. IT SHALL BE TRAFFIC-RATED AS TESTED BY AN OFFICIAL TESTING LABORATORY TO MEET AASHTO STANDARD FOR "H-20" TRUCK LOADINGS.
4. THE TOP OF THE WELL SHALL BE PERMANENTLY MARKED WITH LARGE LETTERS "MONITORING WELL."
5. THE WELL COVER SHALL BE BOLT DOWN OR EQUIVALENT TO PROVIDE PROTECTION AGAINST UNAUTHORIZED ACCESS.
6. THE TOP OF THE WELL SHALL BE SET 2 INCHES ABOVE SURROUNDING GRADE TO PROVIDE FOR DRAINAGE AWAY FROM THE COVER, EXCEPT FOR WELLS INSTALLED IN SIDEWALK OR PAVED AREAS WHERE TOP OF THE CONCRETE PAD SHALL BE INSTALLED FLUSH AND MATCH EXISTING CONDITIONS.
7. A CONCRETE PAD WITH A MINIMUM THICKNESS OF 6 INCHES SHALL BE CONSTRUCTED AROUND THE WELL BOX. THE PAD SHALL EXTEND LATERALLY A MINIMUM OF 12 INCHES FROM OUTSIDE OF THE WELL BOX. THE PAD SHALL BE CONSTRUCTED TO BE FREE OF CRACKS OR OTHER DEFECTS LIKELY TO AFFECT WATER TIGHTNESS.
8. A LOCKING WATERTIGHT WELL CAP SHALL BE INSTALLED AT THE TOP OF THE WELL CASING SO THAT SURFACE WATER THAT MAY ENTER THE VAULT WILL NOT ENTER THE WELL. THE WELL COVER SHALL BE WATERTIGHT TO PROTECT AGAINST ENTRY OF SURFACE WATER.
9. MONITORING WELLS SHALL BE CONSTRUCTED IN ACCORDANCE WITH THE CALIFORNIA WELL STANDARDS.

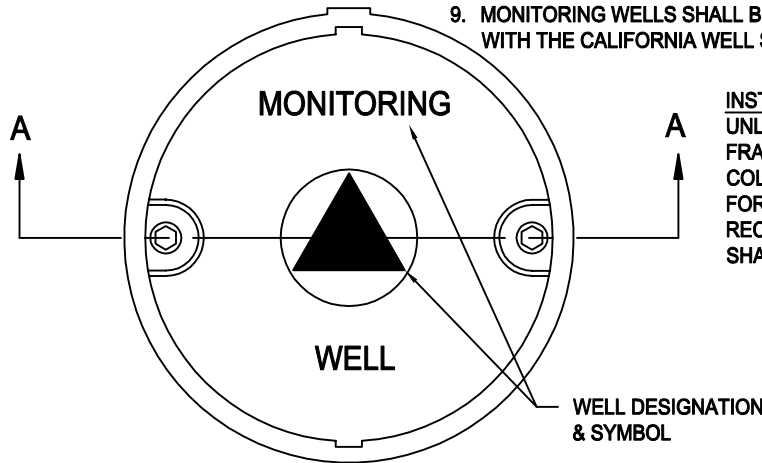

INSTALLATIONS IN NON PAVED AREAS UNLESS OTHERWISE SPECIFIED, SET FRAME 2" ABOVE FINISHED GRADE. COLLAR SHALL BE FORMED (CIRCULAR FORM). EXPOSED EDGES SHALL RECEIVE 1/2" RADIUS AND SURFACE SHALL RECEIVE A SWEAT FINISH.

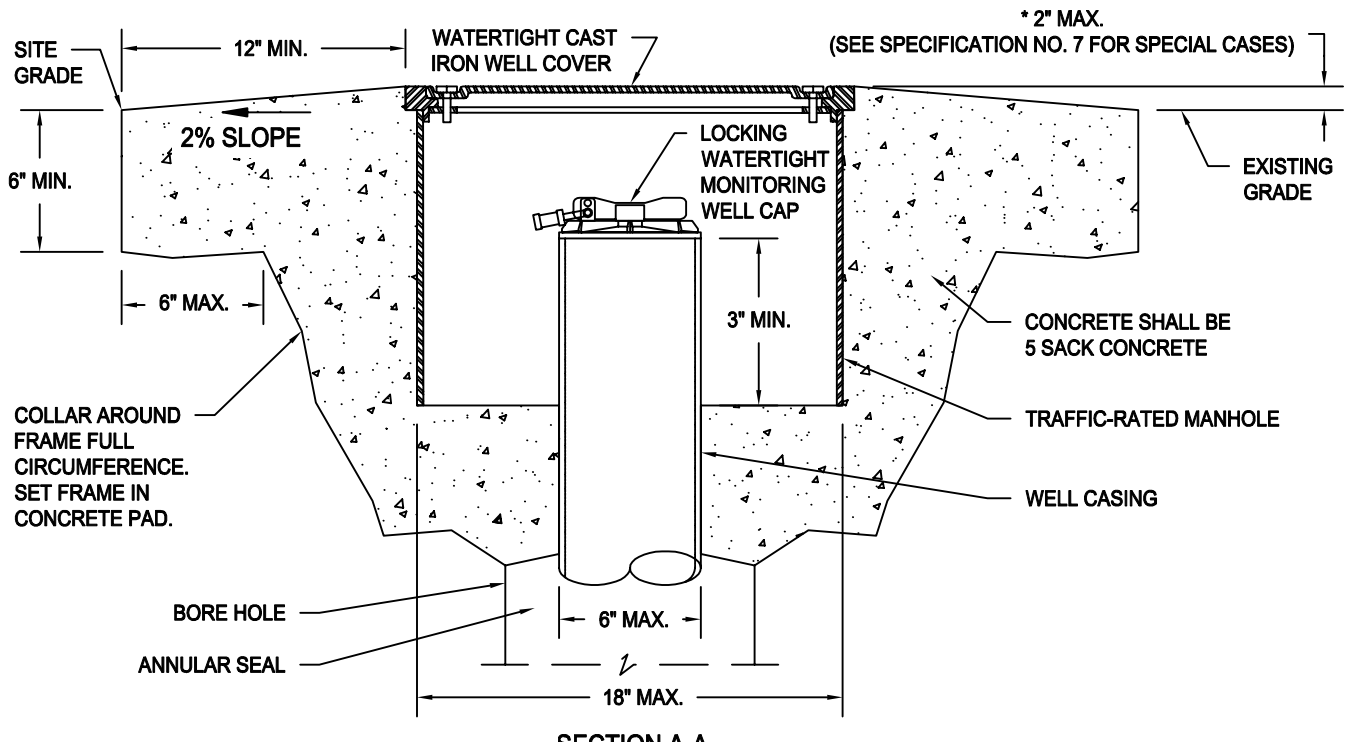

**ROOT CREEK WATER DISTRICT
STANDARD DETAIL**

PREPARED BY: *Stephen Grisez*
STEPHEN GRISEZ
NICK BRUNO, RCWD PRESIDENT

**MONITORING WELL MANHOLE
CONSTRUCTION DETAIL**

SCALE: NOT TO SCALE

DATE ADOPTED: 8-12-2019

W-31

SHEET 31 OF 37

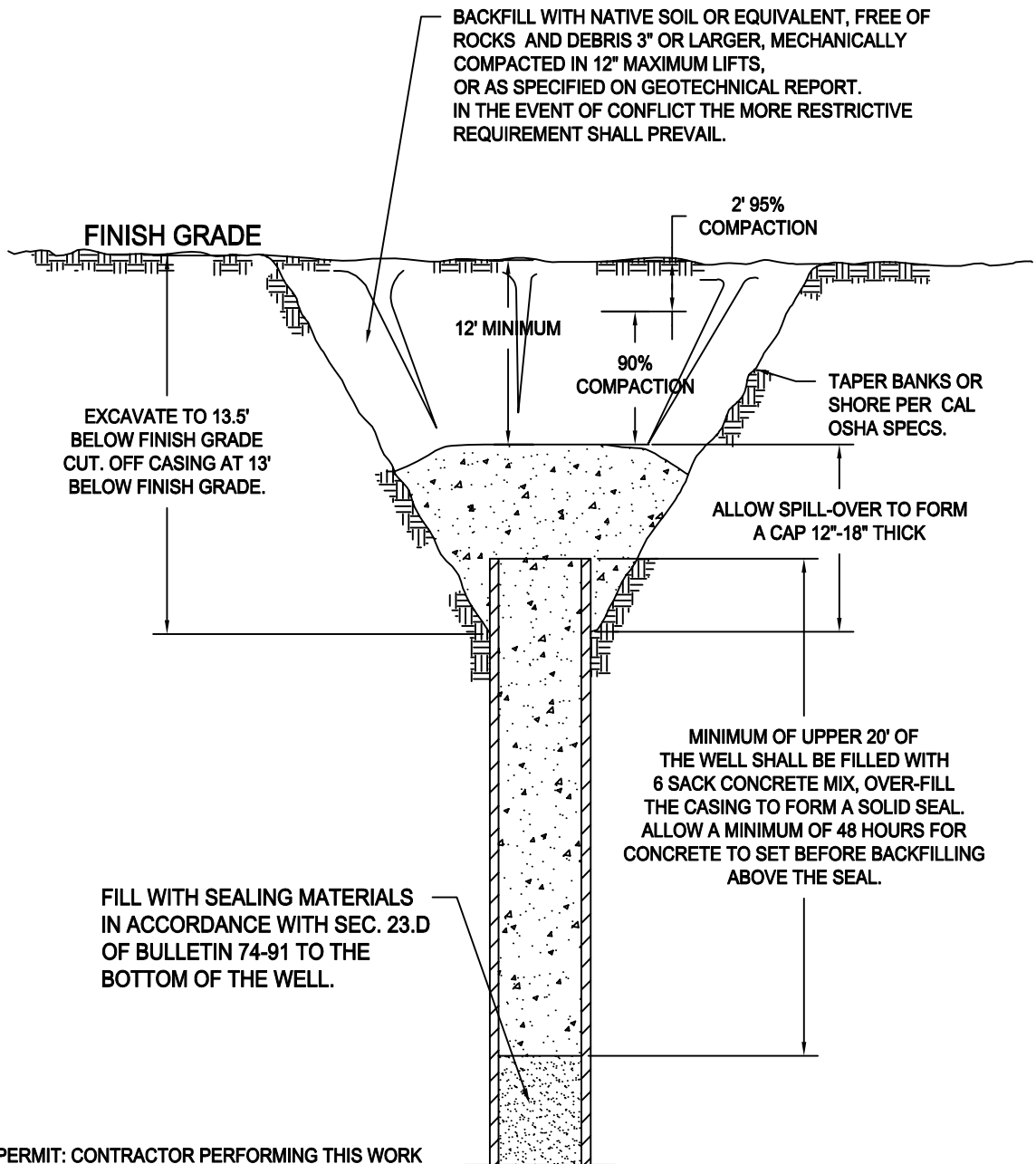

PERMIT: CONTRACTOR PERFORMING THIS WORK SHALL OBTAIN A MADERA COUNTY PERMIT AND ABIDE BY ALL PERMIT REQUIREMENTS.

NOTE: ADDITIONAL DEPTH ADDRESSES POSSIBLE FUTURE UTILITIES AND SWIMMING POOL EXCAVATIONS.

CURRENT ISSUE OF REFERENCE: STATE OF CALIFORNIA DEPT. OF WATER RESOURCES WATER WELL STANDARD BULLETIN 74-91



ROOT CREEK WATER DISTRICT
STANDARD DETAIL

PREPARED BY: STEPHEN GRISEZ
Stephen Grisez
NICK BRUNO, RCWD PRESIDENT

WATER WELL DESTRUCTION

SCALE: NOT TO SCALE

DATE ADOPTED: 8-12-2019

W-32

SHEET 32 OF 37

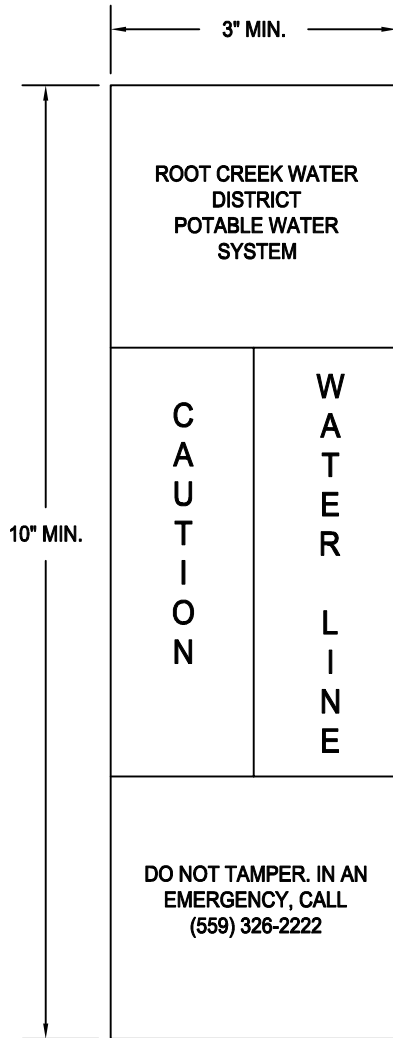

NOTES

1. DECALS SHALL BE FURNISHED BY OWNER OR RCWD.
2. DECALS SHALL BE AFFIXED TO CONVEX SIDE OF MARKER ONLY AND FACE IMPROVEMENT.
3. FURNISH & INSTALL 66" TUFF FLEX WHITE UTILITY POSTS TO A DEPTH OF 18".
4. MARKERS SHALL BE INSTALLED AT ALL NON-SURFACED AREAS AT ALL ANGLE POINTS, VALVES, & 250' O.C. MINIMUM.



**ROOT CREEK WATER DISTRICT
STANDARD DETAIL**

UTILITY MARKER DETAIL

PREPARED BY: STEPHEN GRISEZ
Stephen Grisez
NICK BRUNO, RCWD PRESIDENT

SCALE: NOT TO SCALE

DATE ADOPTED: 8-12-2019

W-33

SHEET 33 OF 37

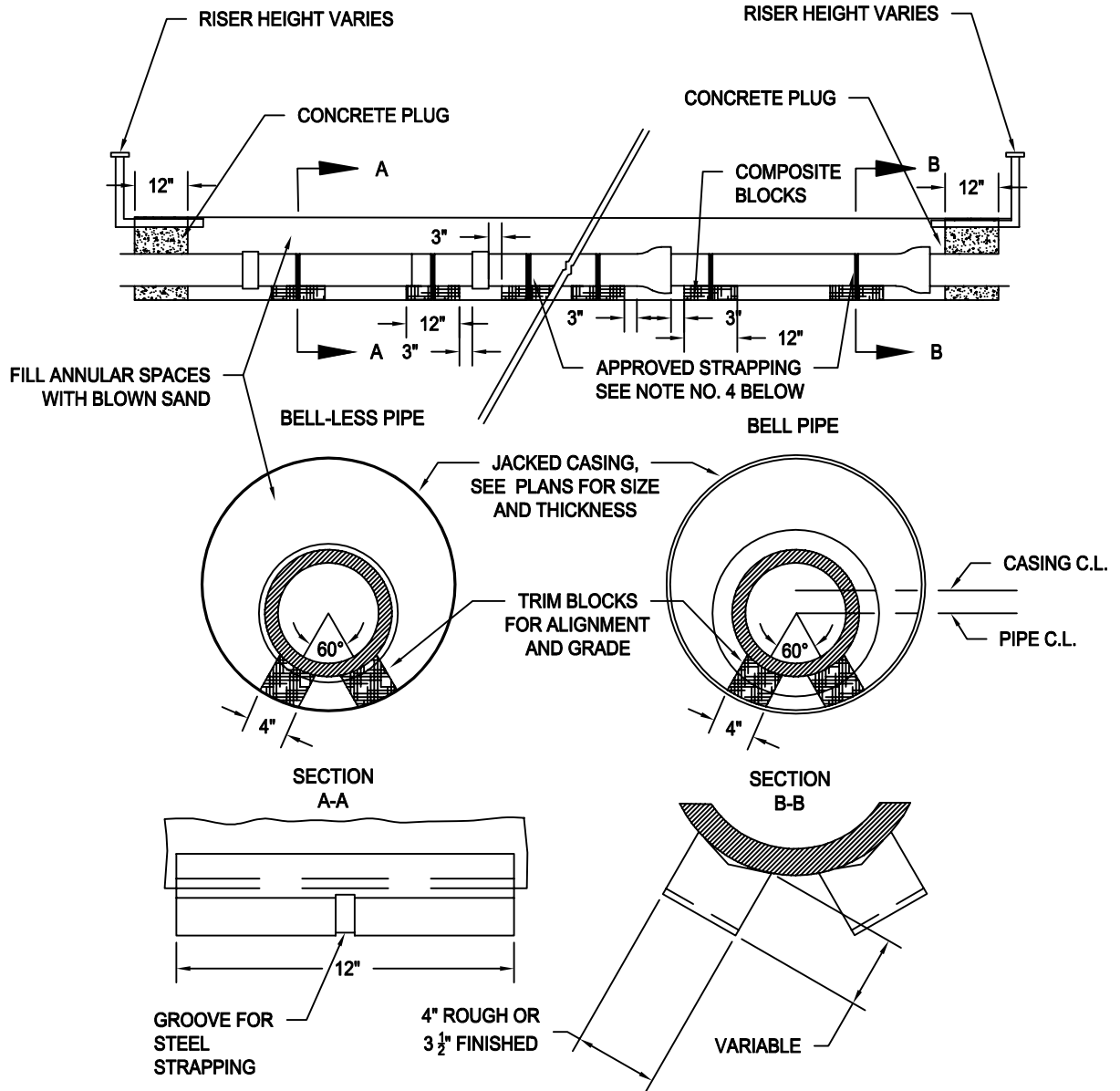

NOTES:

1. WHEN JACKING CASING, GRADE SHALL BE SET SO CENTER LINE OF CASING COINCIDE WITH CENTER OF WATER MAIN.
2. BLOCKS SHALL BE COMPOSITE.
3. BLOCKS SHALL VEED TO FIT CONTOUR OF PIPE.
4. BLOCKS SHALL BE STRAPPED TO THE PIPE WITH STEEL STRAPPING OR APPROVED WIRE BANDS.
5. PLUG ENDS OF CASING WITH 12 INCHES MINIMUM OF CONCRETE.
6. CONCRETE SHALL BE 6 SACK CONCRETE & 3,000 PSI MINIMUM.
7. MANUFACTURED SKIDS ARE ALSO ACCEPTABLE TO AND SHALL BE INSTALLED NEAR SPIGOT, MID-POINT, AND BELL (3 PER JOINT).
8. ALL WATER SYSTEM MATERIALS THAT COME INTO CONTACT WITH POTABLE WATER SHALL BE ANSI/NSF STANDARD-61 CERTIFIED OR EQUIVALENT AND SHALL BE LEAD FREE.



**ROOT CREEK WATER DISTRICT
STANDARD DETAIL**

PREPARED BY: STEPHEN GRISEZ
Stephen Grisez
NICK BRUNO, RCWD PRESIDENT

WATER PIPE IN JACKED STEEL CASING

SCALE: NOT TO SCALE

DATE ADOPTED: 8-12-2019

W-34

SHEET 34 OF 37

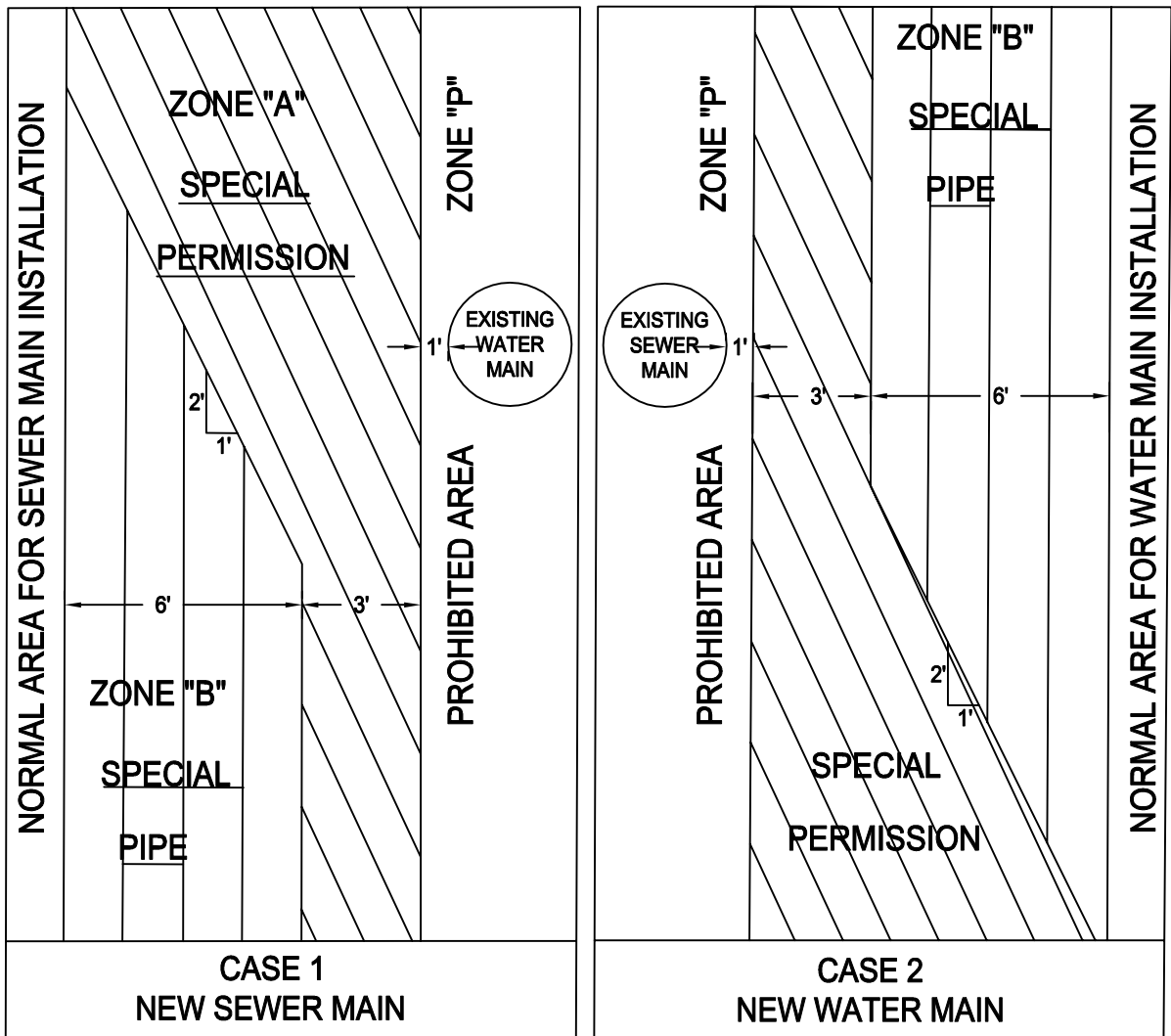

NOTES:

1. ZONES IDENTICAL ON EITHER SIDE OF CENTER LINES.
2. ZONES "P" ARE PROHIBITED ZONES, NO VARIANCES OR SPECIAL CASES
3. ZONES A & B ARE USED ONLY WHEN 10' MINIMUM SEPARATION CANNOT BE ATTAINED.
4. NORMAL CLASS 150 PIPE SHALL BE DEFINED AS PVC, C-900, DR-18 PIPE AND SPECIAL CLASS 200 PIPE SHALL BE DEFINED AS PVC, C-900, DR-14 PIPE.
5. THIS DETAIL MAY ONLY BE USED WHEN WRITTEN APPROVAL IS GRANTED BY THE DISTRICT ENGINEER AND STATE WATER RESOURCES CONTROL BOARD DIVISION OF DRINKING WATER (559) 447-3300.
6. DISTANCES SHOWN MEASURED TO FACE OF PIPE AND ARE CLEAR SEPARATIONS.



**ROOT CREEK WATER DISTRICT
STANDARD DETAIL**

PREPARED BY: STEPHEN GRISEZ
Steph Grisez
 NICK BRUNO, RCWD PRESIDENT

**SEWER AND WATER MAIN PARALLEL
CONSTRUCTION SEPERATION**

SCALE: NOT TO SCALE
 DATE ADOPTED: 8-12-2019

W-35
 SHEET 35 OF 37

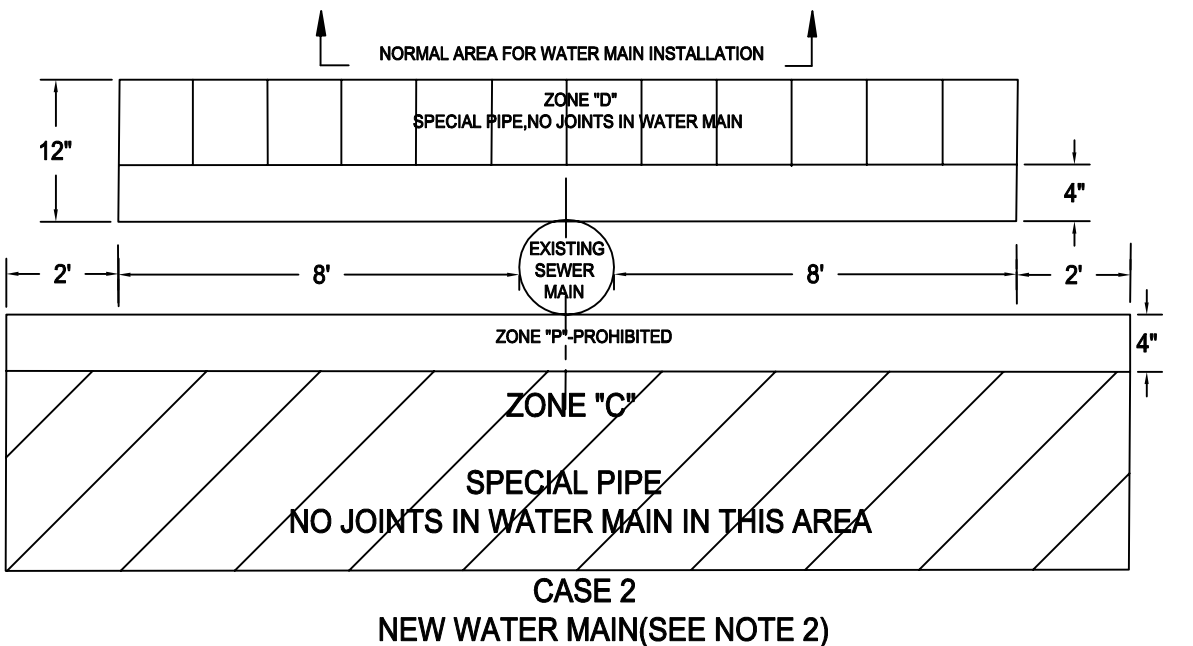
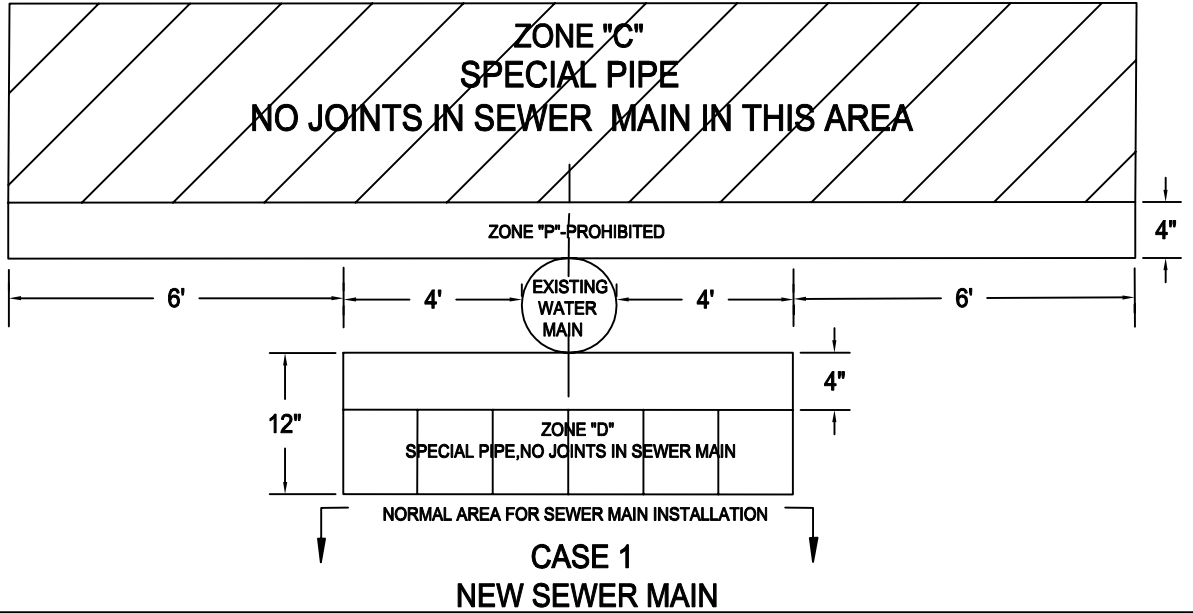

1. ZONES "P" ARE PROHIBITED ZONES, NO VARIANCES OR SPECIAL CASES
2. A NEW WATER MAIN CROSSING ANY PIPE CARRYING NOT-POTABLE FLUIDS SHALL BE CONSTRUCTED NO LESS THAN 45 DEGREES TO THE PIPE BEING CROSSED.
3. NORMAL CLASS 150 PIPE SHALL BE DEFINED AS PVC, C-900, DR-18 PIPE AND SPECIAL CLASS 200 PIPE SHALL BE DEFINED AS PVC, C-900, DR-14 PIPE.
4. THIS DETAIL MAY ONLY BE USED WHEN WRITTEN APPROVAL IS GRANTED BY THE DISTRICT ENGINEER AND STATE WATER RESOURCES CONTROL BOARD DIVISION OF DRINKING WATER (559) 447-3300.



**ROOT CREEK WATER DISTRICT
STANDARD DETAIL**

PREPARED BY: STEPHEN GRISEZ
Steph Grisez
NICK BRUNO, RCWD PRESIDENT

**SEWER AND WATER MAIN CROSSING
CONSTRUCTION SEPERATION**

SCALE: NOT TO SCALE

DATE ADOPTED: 8-12-2019

W-36

SHEET 36 OF 37

NOTES

1. TAPPING SLEEVE SHALL BE USED ONLY WHERE EXISTING PIPE CANNOT BE INSTALLED WITH A VALVE PER STANDARD DETAIL W-9.
2. USE OF TAPPING SLEEVE SHALL BE APPROVED BY THE DISTRICT ENGINEER ON A CASE BY CASE BASIS.
3. TAPPING SLEEVE SHALL BE ROMAC STAINLESS STEEL OR DISTRICT ENGINEER APPROVED EQUAL.
4. TAPPING SLEEVE SHALL BE SMALLER THAN PIPE TO BE TAPPED.
5. TAPPING SLEEVE INSTALLATION SHALL BE IN STRICT CONFORMANCE WITH MANUFACTURER REQUIREMENTS INCLUDING BOLT TORQUE.
6. FIBER GASKET TO BE INSTALLED BETWEEN VALVE AND TAPPING TEE.
7. STAINLESS STEEL NUTS AND BOLTS (USE ANTI SEIZE COMPOUND ON THREADS) ATTACHING VALVE TO TAPPING TEE.
8. TAPPING TEE AND VALVE IS TO BE INSTALLED LEVEL.
9. TEST PLUG TO BE REMOVED AND USED TO TEST SEAL BEFORE TAPPING PIPE. WATER TEST SHALL BE AT 150 PSI.
A. HYDROSTATIC TEST TO LAST 5 MINUTES WITH NO (0 PSI) DROP OR VISIBLE SIGNS OF WEEPING OR LEAKING.
10. TEST PLUG TO BE REPLACED AFTER TEST.
11. FLUSH NEWLY INSTALLED VALVE AFTER TAP TO REMOVE AND SHAVINGS FROM WATER MAIN.
12. HOT TAP TEE AND VALVE SHALL BE BACKFILLED WITH WASHED CONCRETE SAND 1' ABOVE TOP OF PIPE AND COMPACTED TO 90% RELATIVE COMPACTION.

13. VALVE BOX INSTALLATION (W9).
14. IF INSTALLED IN PAVEMENT BACKFILL PAVEMENT SHALL BE PER DETAIL ST-4.
15. ADJACENT JOINTS TO BE RESTRAINED PER RCWD STANDARD W-3.
16. CONCRETE THRUST BLOCK SHALL BE 3,500 PSI AND MINIMUM BEARING AREA OF 8ft² AND POURED AFTER INSTALLATION WRAPPED IN VISQUEEN.
17. CHLORINE WASH PER STANDARDS TO BE PERFORMED AFTER TAP.

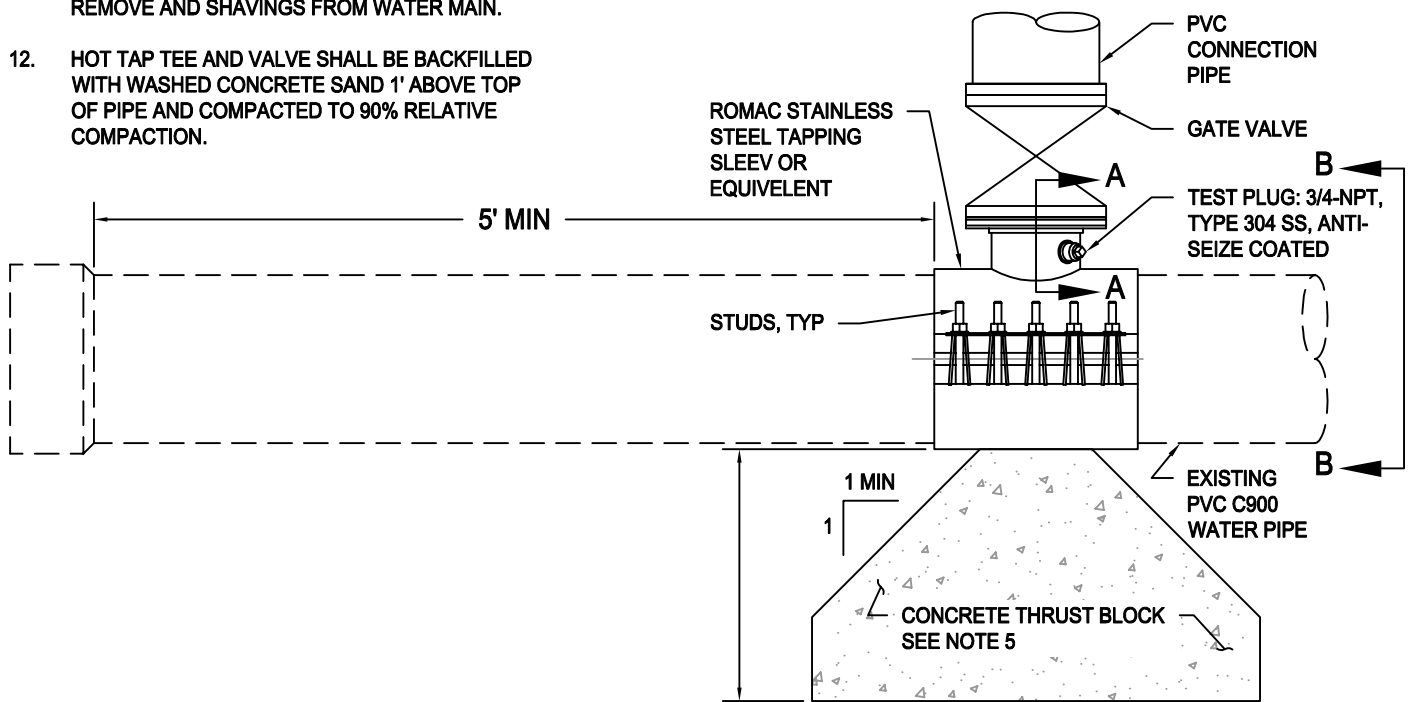
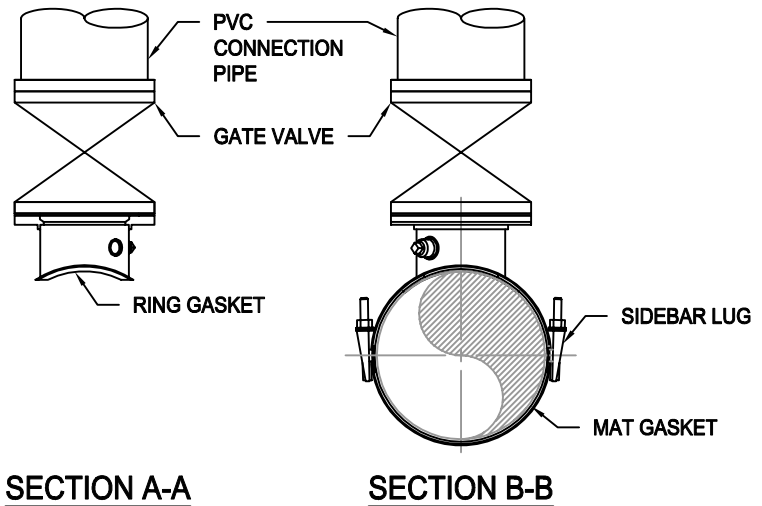

**ROOT CREEK WATER DISTRICT
STANDARD DETAIL**

PREPARED BY: *Stephen Grisez*
STEPHEN GRISEZ
NICK BRUNO, RCWD PRESIDENT

WATER PIPE HOT TAP

SCALE: NOT TO SCALE

DATE ADOPTED: 10-14-2019

W-37

SHEET 37 OF 37

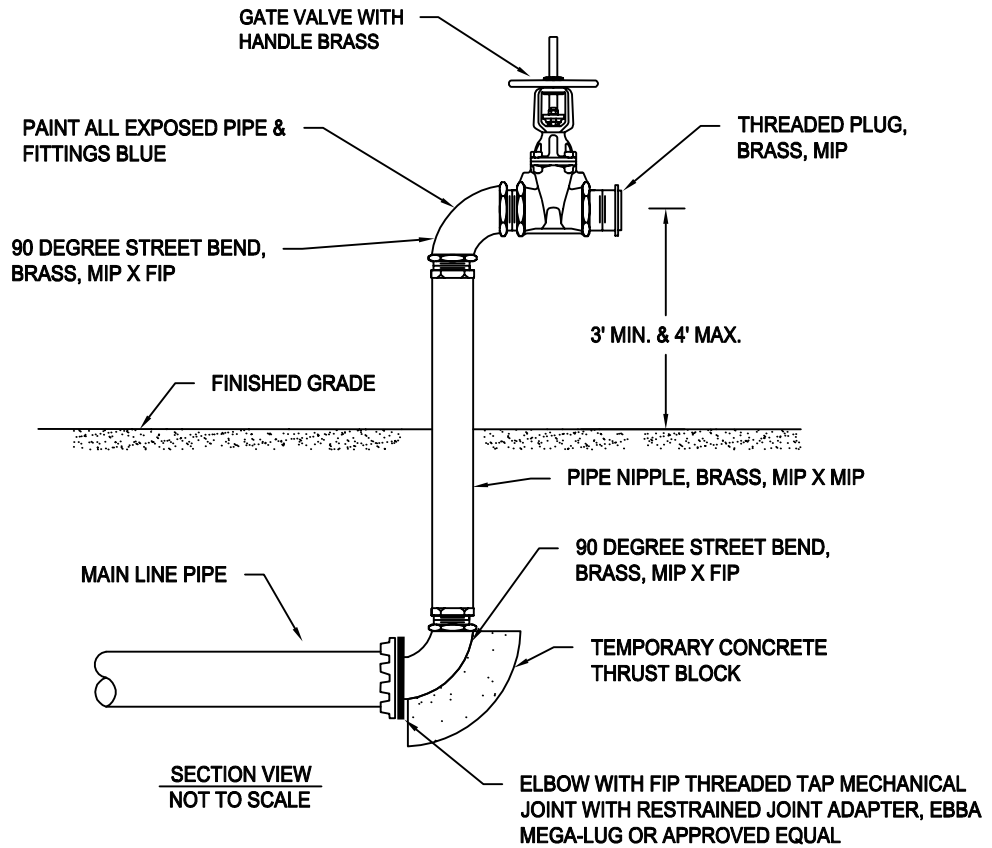

TEMPORARY BLOW-OFFS MAY BE USED AT LOCATIONS DEFINED BY ENGINEER OR CONSTRUCTION MANAGER WHERE THIS TYPE OF TEMPORARY ASSEMBLY IS APPROPRIATE.

NOTES:

1. ALL FITTINGS SHALL BE SECURED WITH RETAINING GLANDS AND HARNESSSES AS APPLICABLE.
2. PLACE VALVES AND BLOW-OFFS OUTSIDE SIDEWALK AND DRIVEWAY AREAS.
3. BRASS BLOW-OFF FITTINGS 4" OR LARGER MAY BE REPLACED WITH FLANGED DUCTILE PIPE, FITTINGS AND BLIND FLANGE (RESTRAINED JOINTS NOT PERMITTED).
4. ALL WATER SYSTEM MATERIALS THAT COME INTO CONTACT WITH POTABLE WATER SHALL BE ANSI/NSF STANDARD-61 CERTIFIED OR EQUIVALENT AND SHALL BE LEAD FREE.

BLOW-FLOW SCHEDULE	
PIPE SIZE	
MAIN	BLOW-OFF
4"	2"
6"	2"
8"	4"
10"	4"
12"	4"
14"	4"
16" OR LARGER	4"



**ROOT CREEK WATER DISTRICT
STANDARD DETAIL**

PREPARED BY: *Stephen Grisez*
STEPHEN GRISEZ
NICK BRUNO, RCWD PRESIDENT

**TEMPORARY BLOW OFF ASSEMBLY WITH
CONCRETE THRUST RESTRAINT**

SCALE: NOT TO SCALE

DATE ADOPTED: 12-9-2019

W-38

SHEET 38 OF 39

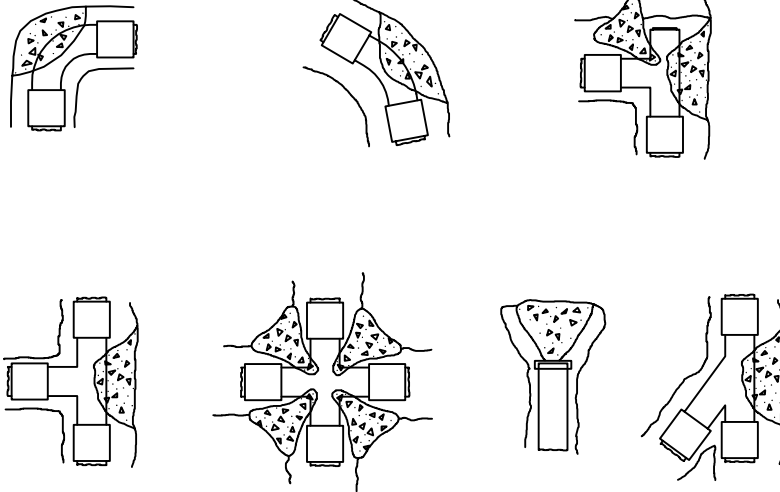

MAX INTERNAL PRESSURE (PSI)		150			
SOIL BEARING PRESSURE (PSF)		1500			
SAFETY FACTOR		1			
MINIMUM BEARING AREA (SF)					
PIPE SIZE	DEAD END OR TEE	90° BEND	45° BEND	22.5° BEND	11.25° BEND
3	0.2	0.3	0.2	0.1	0.0
4	0.4	0.6	0.3	0.2	0.1
6	0.9	1.3	0.7	0.4	0.2
8	1.7	2.4	1.3	0.7	0.3
10	2.6	3.7	2.0	1.0	0.5
12	3.8	5.3	2.9	1.5	0.7
16	6.7	9.5	5.1	2.6	1.3
18	8.5	12.0	6.5	3.3	1.7
20	10.5	14.8	8.0	4.1	2.1
24	15.1	21.3	11.5	5.9	3.0
30	23.6	33.3	18.0	9.2	4.6
36	33.9	48.0	26.0	13.2	6.7
42	46.2	65.3	35.3	18.0	9.1
48	60.3	85.3	46.2	23.5	11.8

NOTES

1. ALL FITTINGS TO BE WRAPPED IN 4 MIL VISQUEEN.
2. CONCRETE SHALL NOT ENCROACH ON END FITTINGS.
3. CONCRETE SHALL BEAR AGAINST UNDISTURBED SOIL.
4. CONCRETE TO HAVE ULTIMATE STRENGTH OF 3000 PSI @ 28 DAYS.



**ROOT CREEK WATER DISTRICT
STANDARD DETAIL**

PREPARED BY: STEPHEN GRISEZ

 NICK BRUNO, RCWD PRESIDENT

THRUST BLOCKS

SCALE: NOT TO SCALE

DATE ADOPTED: 12-9-2019

W-39

SHEET 39 OF 39